

Item	Part #	Description	Qty.
1.	1705295	Solenoid	1
2.	1800602	Rocker Switch	1
3.	1809061	Cable Assembly	1
4.	1703896	Solenoid Cover	1
5.	1800440	Rocker Switch Bracket	1
6.	1808844	Nylon Lock Nut - #10	2
7.	1704905	Flanged Cap Screw - #10 x 1"	2
8.	1801486	Ring Terminal - 3/8" x 8 Ga.	2
9.	1800430	Ring Terminal - 1/4" x 8 Ga.	8
10.	1800441	Butt Connector - 18-22 Ga.	3
11.	1801598	Circuit Breaker - 20 Amp - 24V	1
12.	1800802	Sheet Metal Screw - #10 x 1"	4

WIRE CONTROL BOX



CAUTION

Do not spray electronic components with pressure washers or hoses.

STEP 1: Mount solenoid in dry location, such as battery box, cab or under cab. Fasten with screws 7 and nuts 6. Do not tighten fasteners at this time. Fasten auto-reset circuit breaker to inside wall of truck's battery box with screws 12.

STEP 2: Cut dual-conductor wire long enough to run from solenoid to motor. Crimp two ring-connectors 9 on one end of wire for solenoid, and two ring connectors 9 on opposite end of wire for motor. Connect wire to motor and solenoid as shown

NOTE: New electric motor kits include double-strand wire. If using older motor kit, use existing wire on truck.

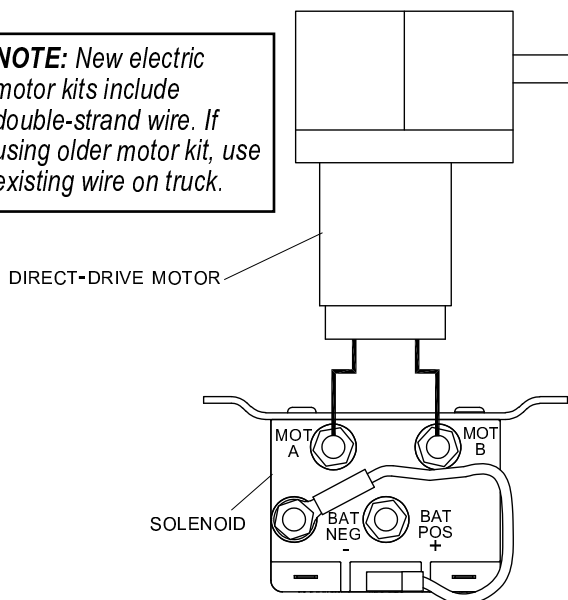

STEP 3: Cut second section of wire long enough to run from solenoid to battery. Crimp end of wire with two ring connectors 9 for solenoid. Crimp other end of wire with ring connector 9 for circuit breaker (red wire) and ring connector 9 for negative post on battery (black wire). Connect end with two ring connectors 9 to posts on solenoid marked BATT+ and BATT-. Connect opposite end of wire to circuit breaker post marked AUX (1/4" ring connector) and negative post of battery (3/8" ring connector).

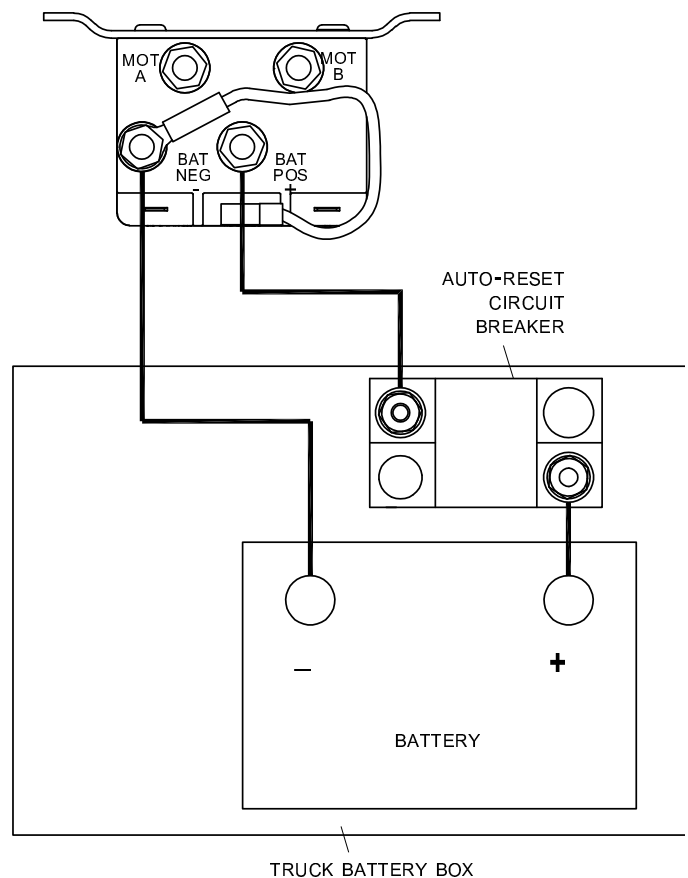

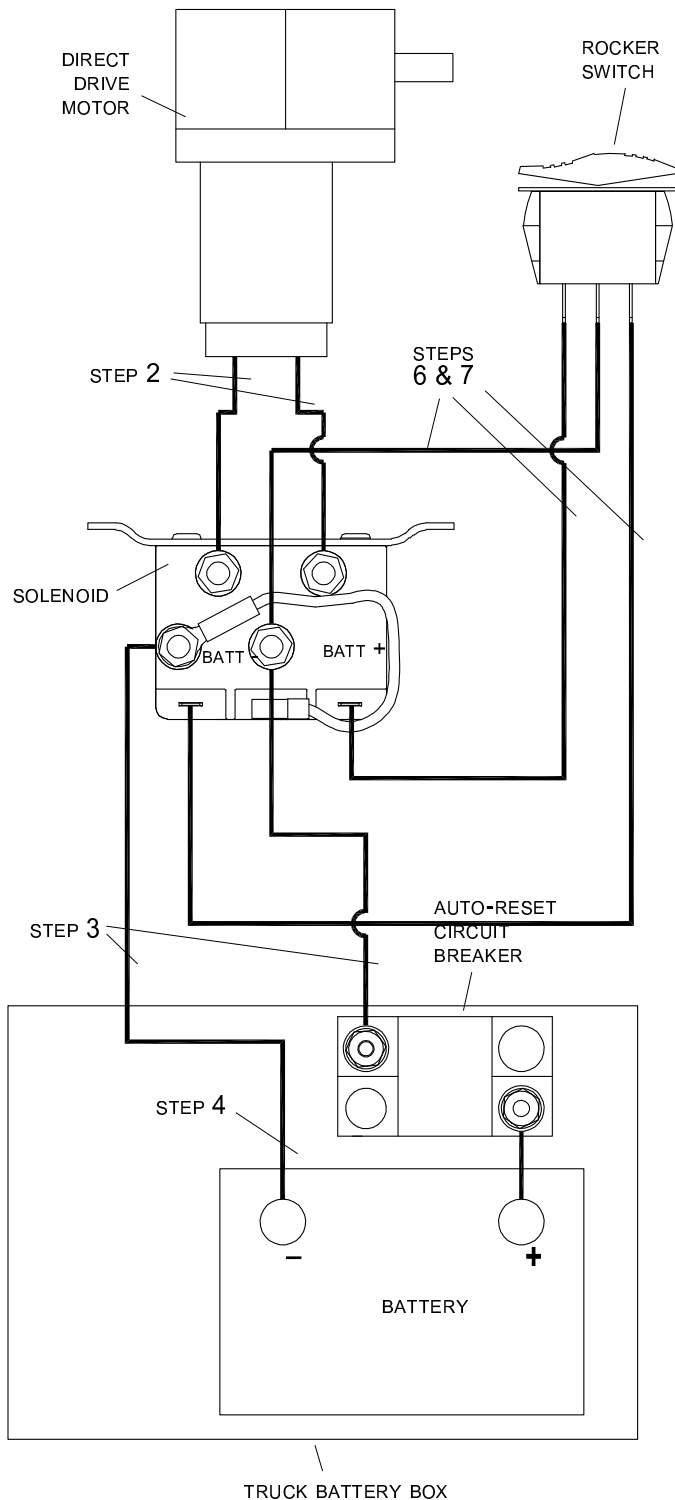

CAUTION

Separate wire strands with knife to ensure wire insulation remains intact. Do not pull dual-conductor wire apart to make single strands of wire, insulation could be damaged and cause short in wire. Equipment could be damaged and personal injury could occur.

STEP 4: Cut section of remaining dual-conductor wire to make single strands of wire. Cut wire 18" long or less, enough wire to run from positive + terminal on battery to circuit breaker. Crimp one end with ring-connector ③ for positive + battery post and other end with ring connector ④ for circuit breaker. Connect wire to positive + battery post and circuit breaker post marked BATT as shown in diagram.

STEP 5: Choose one method below to install rocker switch:

- Insert rocker switch into spare cutout in dashboard of truck cab.
- Cut 1 1/2" x 1 3/16" hole in dashboard of cab and install rocker switch.
- Mount rocker switch bracket in suitable location in cab of truck and fasten with screw and washers. Install rocker switch into bracket.

STEP 6: Run 3-strand jacketed wire from solenoid to rocker switch. Connect end of wire with two quick disconnects and one ring terminal to solenoid. Connect end of wire with three quick disconnects to rocker switch. Connect 3-strand wire to solenoid. Connect ring connector to post marked BATT+. Connect two quick disconnects to tabs.

NOTE: Kit includes three extra butt connectors ⑩ so excess wire can be cut and spliced instead of coiled.

STEP 7: Connect 3-stranded jacketed wire to rocker switch. Connect three quick-disconnects to three blade terminals on rocker switch. Ensure wire going to center tab on rocker switch is same wire connected to positive + post on solenoid (verify they are same color) for tarp system to work correctly.

STEP 8: Slide solenoid cover under bolt head holding solenoid in place. Tighten bolt to hold cover and solenoid in place.

TEST OPERATION

STEP 9: Operate rocker switch and verify tarp direction matches label on rocker. If not, swap two wires connected to tabs on solenoid or two wires connected to motor.

IF DURABUILT™ MOTOR ONLY OPERATES IN ONE DIRECTION:

TRY THIS	RESULT
1. Switch wires connected to motor and operate motor.	If motor still runs only in same direction as before switching wires, replace motor. If motor runs only in opposite direction, motor is good.
2. Remove wires with quick disconnects from terminals ⑤ and ⑥ on solenoid. Run jumper from positive battery post to terminal ⑤ on solenoid and observe motor. Move jumper to terminal ⑥ and observe motor.	If motor does not move at all, jumper is bad. Refasten jumper to battery and try again. If motor only turns one direction, solenoid is bad. Replace solenoid. If motor operates in both directions, solenoid is good. Refasten wires to tabs ⑤ and ⑥ on solenoid.
3. Remove wires on rocker switch posts ⑦ and ⑨. With voltmeter, fasten one lead to tab ③ on rocker switch (with wire still attached) and other lead to ground.	Verify voltage measures about 24 volts. If not 24 volts, reposition lead wires and verify ground is good.
4. Leave one lead wire on ground and, with voltmeter, place other lead wire on rocker switch tab ⑦. Operate switch in both directions while looking at voltmeter. Move lead wire from tab ⑦ to tab ⑨, operating switch in both directions while observing voltmeter.	If voltage measures 24 volts at any time during only one test, switch is faulty. Replace switch. If voltage measures 24 volts at any time during both tests, replace wire from solenoid to switch.

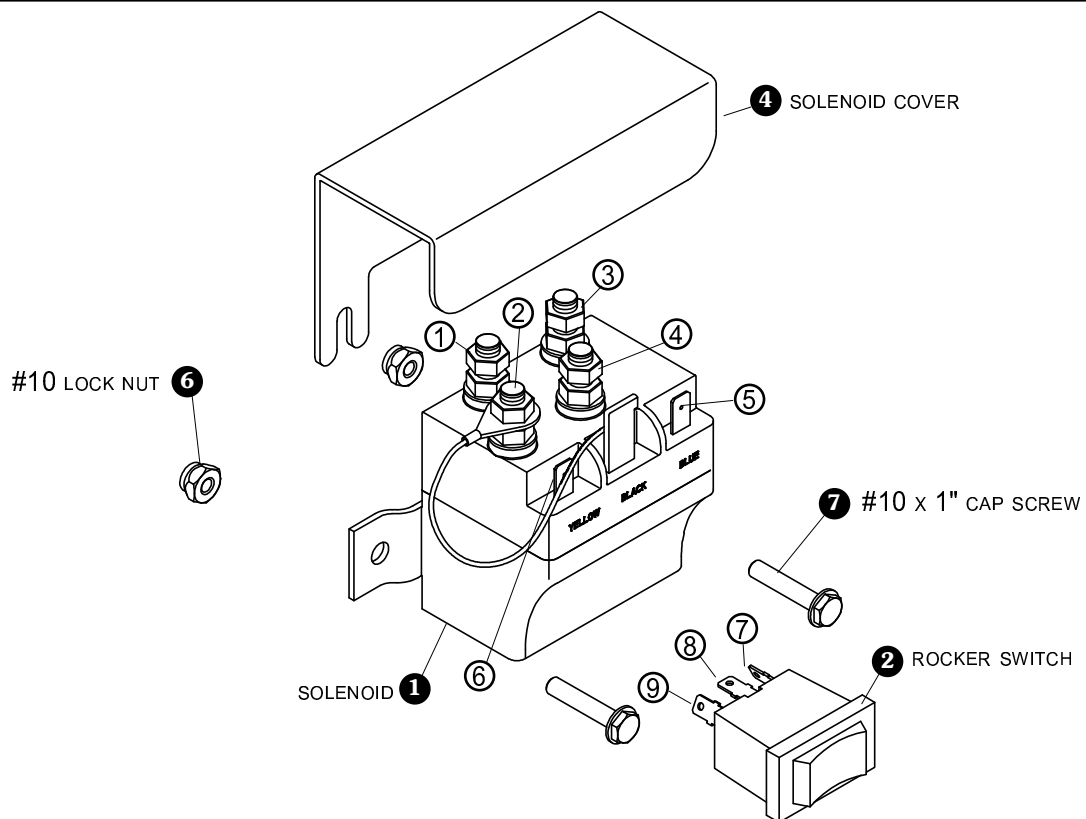

IF DURABUILT MOTOR DOES NOT OPERATE

TRY THIS	RESULT
1. Remove wires connected to motor. Connect jumper cables from battery to motor and use voltmeter to verify 24 volts at motor.	If there are not close to 24 volts at motor, jumper is bad. Reconnect jumper to battery and motor and repeat step 1. If there are about 24 volts at motor, motor is bad. Replace motor. If motor operates, motor is good. Reconnect wires to motor.
2. Remove wires connected to solenoid posts ❶ and ❸. Connect jumper cables from battery to wires. Use voltmeter to verify 24 volts at connection.	If there are not about 24 volts at meter, jumper is bad. Reconnect jumper and repeat step 2. If there are about 24 volts and motor does not run, wire from solenoid to motor are bad. Replace wire. If motor operates, wire from solenoid to motor is good. Reconnect wires to solenoid.
3. Switch wires connected to motor and operate motor.	If motor still only runs in same direction as before wires were switched, replace motor. If motor runs only in opposite direction from before wires were switched, motor is good.
4. Check circuit breaker. Place one lead on circuit breaker post where wires go to solenoid and other lead on negative post on battery.	If voltage measures zero volts, circuit breaker is bad. Replace circuit breaker. If voltage measures about 24 volts, circuit breaker is good.
5. Use voltmeter to check voltage at solenoid. Place one lead on terminal ❶ and other lead on terminal ❷. Operate rocker switch while watching voltage.	If there are about 24 volts initially and voltage goes to zero while operating toggle switch, either circuit breaker is bad, connection is loose or there is a ground. Check all electrical connections and wires. If no problem is found, replace circuit breaker. If there are consistently about 24 volts, all components up to solenoid are working correctly.
6. Remove wires with quick disconnects from solenoid ❸ and ❹. Run jumper cable from positive battery terminal to terminal ❸ on solenoid and observe motor. Move jumper to terminal ❹ and observe motor.	If motor does not move at all, solenoid is bad. Replace solenoid. If motor operates in both directions, solenoid is good. Reconnect wires to terminals ❸ and ❹ on solenoid.
7. Remove outer wires from blades ❶ and ❷ on rocker switch. Connect one lead to center blade ❸ on switch (with wire still connected) and second lead to ground.	Verify there are about 24 volts. If not, reposition leads and verify ground is good. Repeat step 3.
8. Test 1: Using voltmeter, leave one lead on ground and place other lead on rocker switch blade ❶. Operate switch in both directions while watching voltmeter. Test 2: Switch lead from blade ❶ to blade ❷ and operate switch in both directions while watching voltmeter.	If there are consistently 24 volts for only one test, switch is bad. Replace switch. If there are consistently 24 volts during both tests, wire from solenoid to rocker switch is bad. Replace wire.

See illustration on previous page

