



TARPING SYSTEMS & ACCESSORIES

P/N 1809350 Rev. A

OWNER'S MANUAL

Turbo Tarp2™ w/o Mounting Plates (P/N 1809146)

READ BEFORE INSTALLING

3353 SE GRAN PARK WAY ■ STUART, FL 34997
PHONE 1-800-327-8287 ■ FAX 772-287-0431
www.shurco.com

SHOP ONLINE: www.shopshurco.com

PREPAID FREIGHT POLICY. Shur-Co®, LLC

will prepay freight on eligible orders* of Florida-manufactured Donovan products and tarp items shipped from our FL and MI branches that meet the dollar requirements for the shipping destinations specified below.

*Valid within the continental 48 states only. Applies to products purchased at standard pricing; any special pricing will void standard prepaid freight policy and will be addressed on a case-by-case basis. Does NOT apply to Bedliners or Shur-Co® Flatbed products.

INTO FL/MI: Freight prepaid on orders of \$2,500 or more or tarp-only orders of \$1,500 or more. INTO ZONES 1 & 2: Freight prepaid on orders of \$3,000 or more or tarp-only orders of \$2,500 or more. INTO ZONES 3 & 4: Freight prepaid on orders of \$6,000 or more or tarp-only orders of \$3,000 or more.

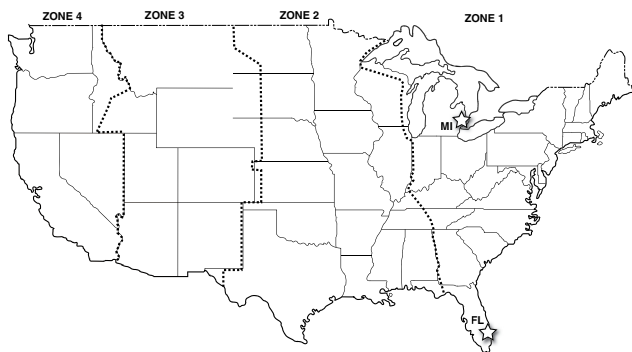

WARRANTY. We warrant all new products are free of defects in materials and workmanship.* This warranty is effective if products are properly installed and used for the purpose for which they were intended and applies to the original buyer only. Except as set forth above or in any product-specific warranty documentation, we make no other warranties, express or implied, including but not limited to warranties of merchantability of fitness for a particular use.

Returns of a product for warranty must be accompanied by a Return Merchandise Authorization number (RMA#), obtained by calling Customer Service at 800-327-8287, and sent, freight paid by us, to Donovan, 3353 SE Gran Park Way, Stuart, FL 34997. All products returned without an RMA# will be refused. When we issue the RMA#, we will also issue a call tag to have

U.P.S. (or other freight company) pick up the product. C.O.D. returns not accepted. We will pay no storage fees for a warranty product return prior to pick by us or the freight company. If a warranty product return is scheduled to be picked up by us, we will pick up the product at our earliest convenience. If a product returned is found, in our judgement, to be defective in material or workmanship, our obligation under this warranty is limited to the repair or replacement of the product, which will be made by us. Repair or replacement will be at our discretion, with replacements being made using current products performing in the equivalent function. Labor charges, other than those incurred at our factory, including, but not limited to, any labor to install a repaired or replacement product, are not covered under this warranty. All expenses associated with delivering defective products to our factory and delivering repaired or replacement products from our factory to the owner will be paid by us.

If the product returned is found, in our judgement, to be non-warrantable, the owner will be contacted to authorize repair work, purchase of a replacement product or return of the product, all of which will be at the owner's expense. Payment authorization must be received by us before any non-warrantable product is repaired, replaced or returned. All expenses associated with delivering the repaired non-warrantable product, a replacement product or the non-warrantable product from our factory to the owner will be paid by the owner.

In no event will we be liable for any damages of any kind to person, product or property, including but not limited to indirect, incidental, special, consequential or punitive damages, or damages for loss of profits or revenue, even if we have been advised of the possibility of such damages. There are no warranties for used products or products that have been repaired, altered, modified or subjected to misuse, negligence or accident. We will not repair or replace products that fail or malfunction due to ordinary wear and tear, except as expressly noted in a product-specific warranty. Use of non-Shur-Co®, LLC parts in conjunction with Shur-Co®, LLC products will void this product warranty.

*Certain products have specific warranties that differ from this warranty, for example motors and electronics. Product-specific warranty documentation is available for these items. In the event of a conflict between this warranty and a product-specific warranty, the product-specific warranty will govern.

RETURN POLICY. All sales final. See WARRANTY above for return details.

OTHER. All prices, product listings, sizes, weights and manufacturing details are subject to change without notice. No person is authorized to modify the foregoing conditions of sale whatsoever.

SHUR-CO®, LLC SERVICE AND DISTRIBUTION CENTERS

Corporate HQ and Outlet Store

SHUR-CO® of SOUTH DAKOTA

2309 Shur-Lok St., PO Box 713
Yankton, SD 57078-0713
Ph 800.474.8756 | Fax 605.665.0501

ShurTite™ Service Centers

SHUR-CO® of CANADA

490 Elgin St., Unit #1
Brantford, Ontario N3S 7P8
Ph 800.265.0823 | Fax 519.751.3997

SHUR-CO® of SIOUX FALLS

47184 258th St., Suite B
Sioux Falls, SD 57107
Ph 844.573.9322 | Fax 605.543.5469

SHUR-CO® of ILLINOIS

Ph 866.356.0246 | Fax 217.877.8270

SHUR-CO® of OHIO

Ph 866.356.0242 | Fax 330.297.5599

SHUR-CO® of COLORADO

10220 Brighton Rd., Unit #1
Henderson, CO 80640
Ph 866.355.9173 | Fax 303.289.2298

SHUR-CO® of FLORIDA

3353 SE Gran Park Way
Stuart, FL 34997
Ph 800.327.8287 | Fax 772.287.0431

SHUR-CO® of ILLINOIS

3993 E. Mueller Ave.
Decatur, IL 62526
Ph 866.356.0246 | Fax 217.877.8270

SHUR-CO® of IOWA

3839 Midway Blvd.
Ft. Dodge, IA 50501
Ph 866.356.0245 | Fax 515.576.5578

SHUR-CO® of MICHIGAN

5100 Lakeshore Dr.
Lexington, MI 48450
Ph 800.327.8287 | Fax 772.287.0431

SHUR-CO® of NORTH DAKOTA

1746 4th Ave. NW
West Fargo, ND 58078
Ph 877.868.4488 | Fax 701.277.1283

SHUR-CO® of OHIO

1100 N. Freedom, St. Rt. 88 & 14
Ravenna, OH 44266
Ph 866.356.0242 | Fax 330.297.5599

SHUR-CO® of TEXAS

34505 I-10 West, S. Frontage Rd.
Brookshire, TX 77423
Ph 866.689.0039 | Fax 281.934.3311

SHUR-CO® UK, Ltd.

Unit 41 Rochester Airport Estates
Laker Rd., Rochester, Kent ME1 3QX
Ph +44 (0)1795.473499
Fax +44 (0)871.272.8278

For more info, log on to our website:

www.donovan-tarps.com

MESSAGE TO OWNERS

Thank you for buying this tarping system from Shur-Co®. We appreciate your confidence in our products. Please read and thoroughly understand this manual before installing and/or operating this system.

Pay particular attention to important safety and operating instructions, as well as warnings and cautions. The hazard symbol  is used to alert users to potentially hazardous conditions and is followed by caution, warning or danger messages.

Failure to READ AND FOLLOW INSTRUCTIONS could result in failure of your tarping system and/or personal injury. Your trailer requirements may, however, call for minor variations to these instructions.

Please inspect your tarping system periodically. Repair or replace worn or damaged parts to your system.

QUESTIONS? CALL OUR HELP LINE:

1-800-327-8287

MON-FRI 8 AM-5 PM EASTERN TIME

SAFETY

We at Shur-Co® are concerned with your safety and the safety of all those operating this system. Therefore, we have provided safety decals at various locations on your tarping system. Keep decals as clean as possible at all times. Replace any decal that has become worn or damaged, painted over or otherwise difficult to read. Replacement decals are available through Shur-Co® dealers.

SAFETY INSTRUCTIONS

- 1. Always wear safety glasses during installation and operation.**
- 2. Stay clear of moving parts.**
- 3. Do not operate under low-hung power lines. Always check for overhead obstructions before opening or closing.**
- 4. Open and close tarp only at job site.**
- 5. Place safety decals in visible locations. Replace worn or damaged decals.**
- 6. No other use of this system is authorized, except as designed.**

RUST PREVENTION

To prevent rust, paint all exposed metal such as weld seams and/or metal exposed by grinding or cutting, with corrosion-resistant paint.

TABLE OF CONTENTS

Hardware Identification..... 1

Tarp Roller Installation.....2-3

Tarp Installation.....3

Crank Installation.....4

Pull Bar Installation.....5-6

J-Hook Installation.....7

Replacement Parts.....8

TOOLS REQUIRED

1. Wrenches - 10mm, 17mm
2. Ratcheting Socket Wrench
3. Sockets - 10mm, 17mm
4. Allen Wrenches - 1/8", 5/32", 3/16"
5. Drill Bits (metal cutting) - 1/4", 3/8", 1 1/8" Hole Saw
6. Center Punch
7. Hammer
8. Tape Measure
9. Flat Head or Phillips Screwdriver
10. Grinder
11. Metal Saw
12. Steel Welder
13. Hex Driver Bit - 5/16"
14. Phillips Driver Bit - #3

1809019 CRANK HANDLE W/SPROCKET

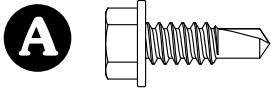

Self-Tapping Screw - 1/4"

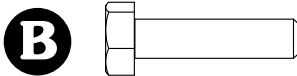

Cap Screw - M6 x 25

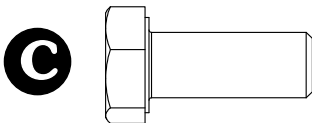

Cap Screw - M10 x 25

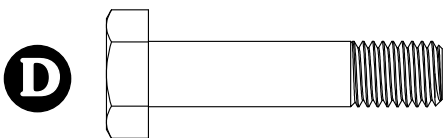

Cap Screw - M10 x 45

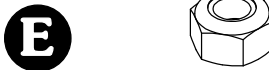

Nylon Lock Nut - M6

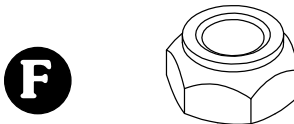

Nylon Lock Nut - M10



Flat Washer - M10

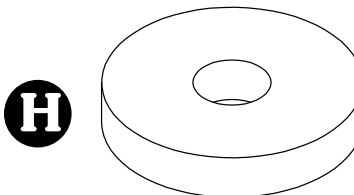

Nylon Spacer

TARP INSPECTION

Tarp length: Measure tarp with slight tension applied. Compare actual tarp length with length stated on sheet attached to tarp. If actual tarp length does not match length on sheet, do not proceed. Call your local dealer or call Shur-Co® Customer Service at 1-800-327-8287.

MODIFY SIDE WALLS

If needed, build up or modify sides of truck bodies to allow pull bar to roll smoothly from tarp housing along top rail of body and over tailgate latch. Fabricate wood or metal to raise entire top rail height or act as ramp to transition pull bar over obstacles, such as tailgate hinges.

TIP: Use steel cable wire to fabricate ramp for rollers to transition over so if tailgate hinge interferes with roller travel, cable wire will flex out of way when tailgate is raised.

BOX PREPARATION

Prepare your box before installing your tarping system. Remove or grind any sharp edges smooth to prevent tarp damage.

To prevent rust, paint all exposed metal, such as weld seams and/or metal exposed by grinding or cutting, with corrosion-resistant paint.

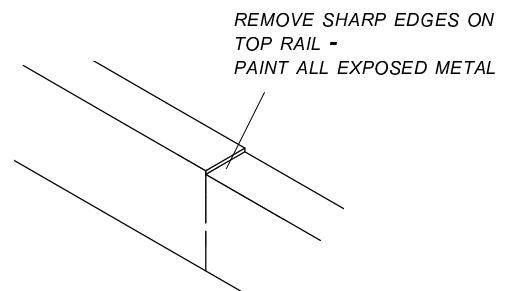

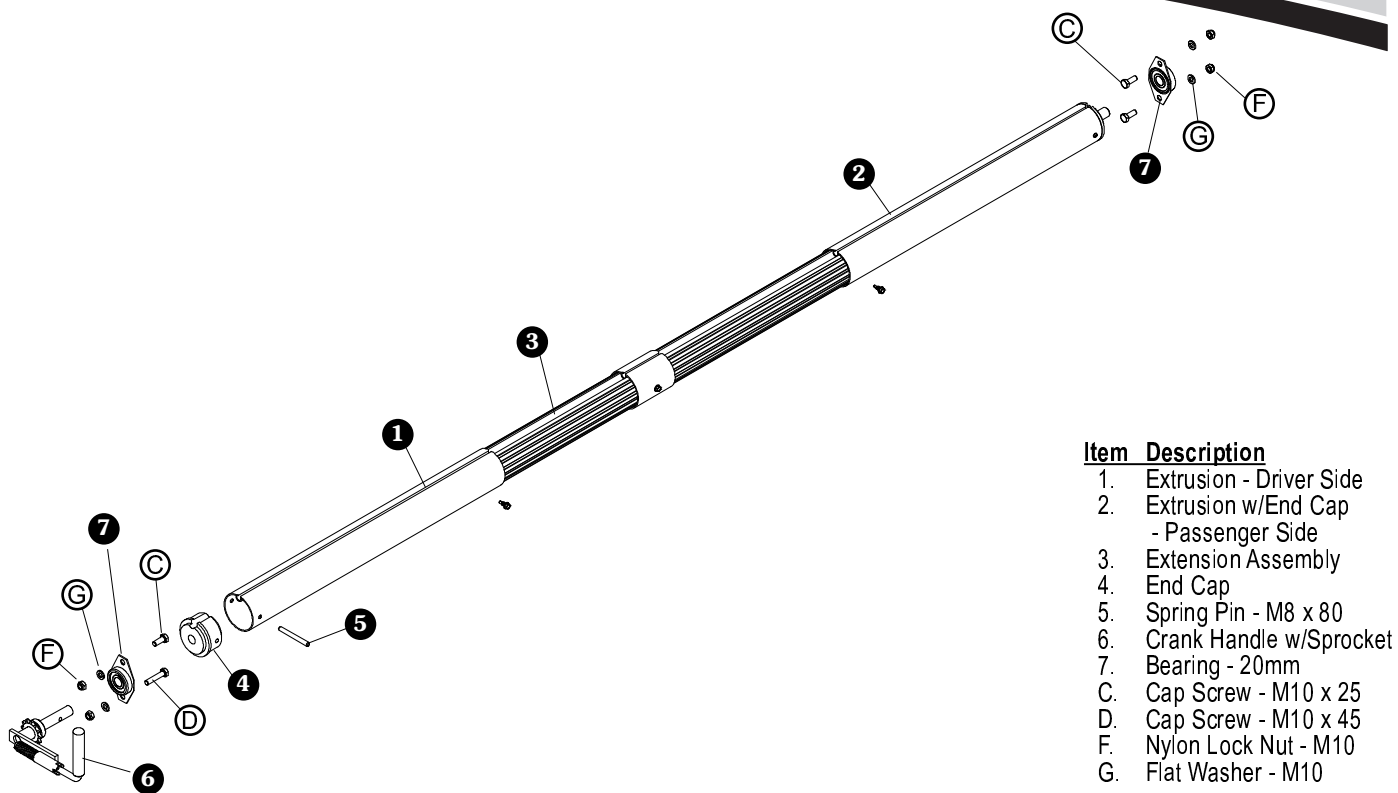

Item	Description
1.	Extrusion - Driver Side
2.	Extrusion w/End Cap - Passenger Side
3.	Extension Assembly
4.	End Cap
5.	Spring Pin - M8 x 80
6.	Crank Handle w/Sprocket
7.	Bearing - 20mm
C.	Cap Screw - M10 x 25
D.	Cap Screw - M10 x 45
F.	Nylon Lock Nut - M10
G.	Flat Washer - M10

NOTE: Inspect parts upon arrival. Contact dealer if any parts are missing. Read and understand instructions for entire system before beginning installation.

DETERMINE MOUNTING LOCATION

STEP 1: Mount tarp roller assembly as far forward as possible on top of truck or trailer to prevent damage by loaders. If using pull bar option, locate tarp roller to allow pull bar to roll freely along top rails.

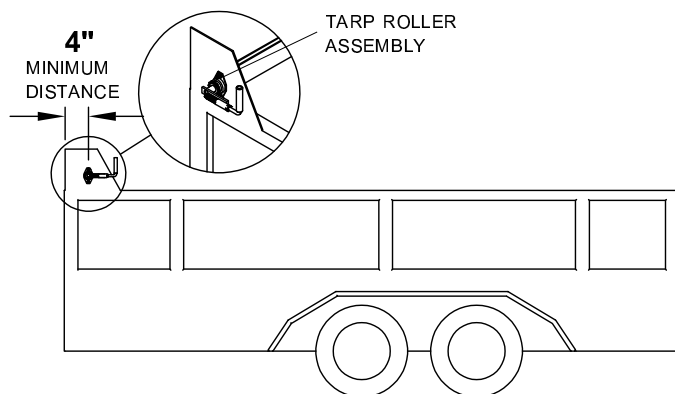

NOTE: Position tarp roller in mounting location on trailer to verify location.

TARP ROLLER INSTALLATION

STEP 1: Mark and drill holes in trailer as shown.

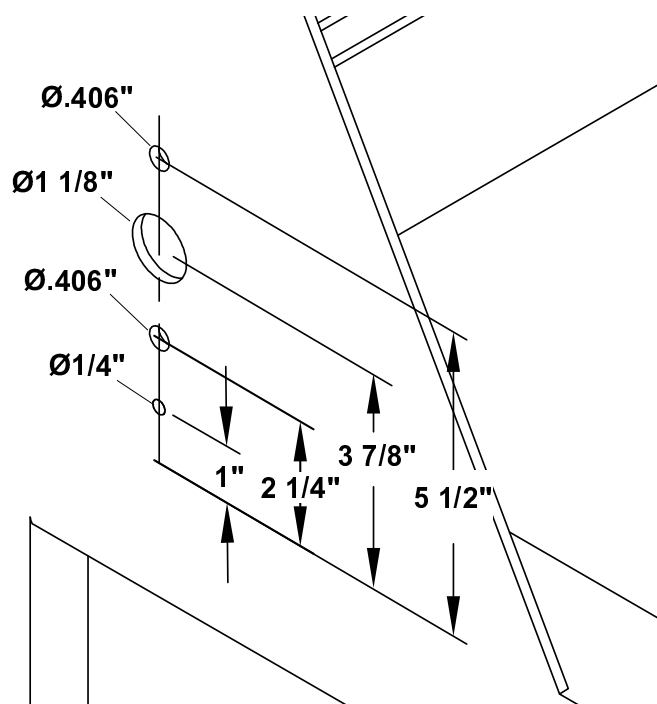

STEP 2: Fasten bearings to trailer with screws **C** and **D**, washers **G** and nuts **F**, or weld in place on both sides.

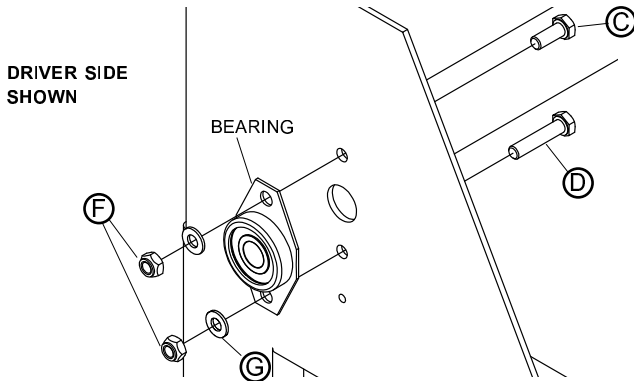

STEP 3: Insert end cap into driver side of tarp roller assembly. Align tarp roller on truck as shown. Insert sprocket/crank handle into end cap/roll tube and secure with spring pin.

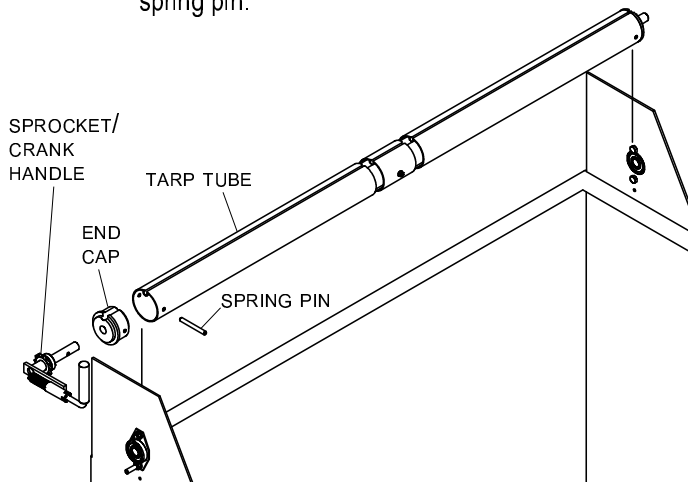

STEP 4: Center extension assembly on tarp roller assembly and measure from center piece to edges of both tarp roller tubes. Measurement will be equal on both sides when extension assembly is centered.

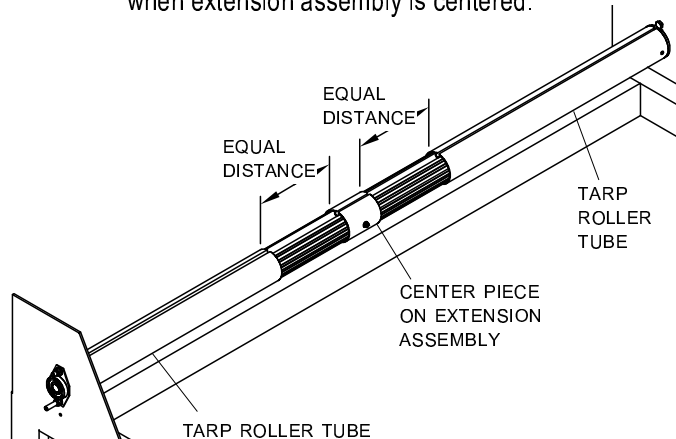

STEP 5: Fasten screws **A** through tarp roller tubes and extension tube as shown.

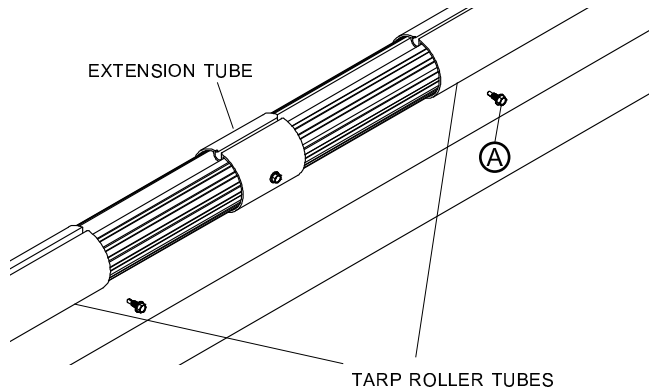

TARP INSTALLATION

STEP 1: Lay tarp flat with top side up and 4" pocket toward rear.

NOTE: Side hems fold to bottom side of tarp and 4" pocket folds to top.

STEP 2: To install tarp, insert tarp splines into groove in tarp roller, starting at center of tarp roller and working spline fully into groove.

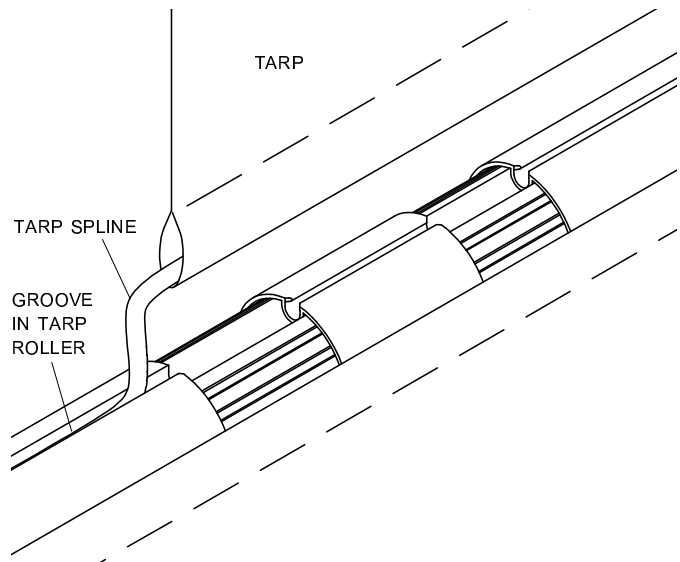

NOTE: If tarp spline cannot be installed into groove in tarp roller at center of tarp roller assembly, insert tarp spline into right hand side of tarp roller.

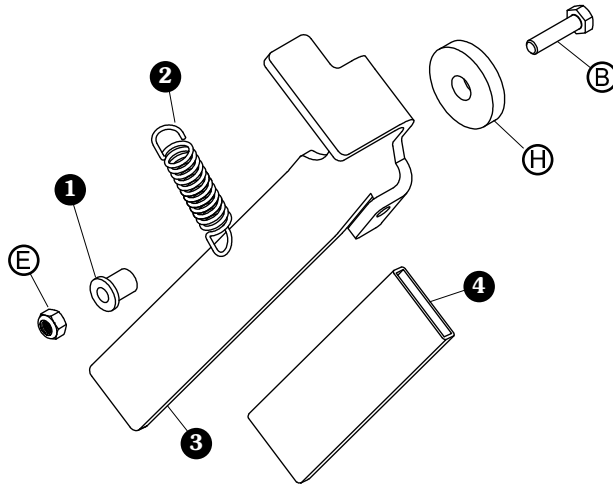

Item	Description
1.	Flanged Bushing
2.	Extension Spring
3.	Pawl Catch
4.	Pawl Handle Grip
B.	Cap Screw - M6 x 25
E.	Nylon Lock Nut - M6
H.	Nylon Spacer

STEP 3: Fasten crank to driver side end plate with screw **B** and nut **E**, assembling spacer **H** and flanged bushing as shown.

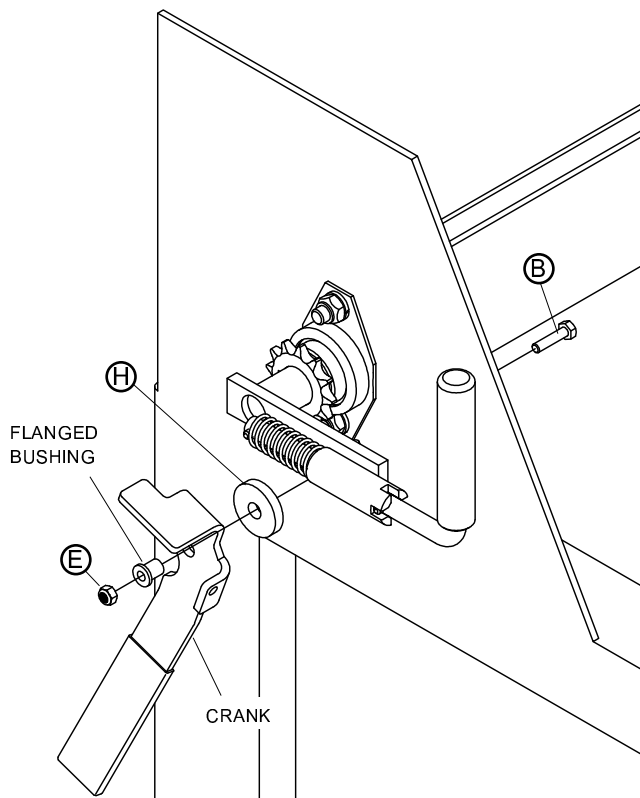

STEP 4: Hook one end of extension spring through hole in crank and other end over screw as shown. Thread nut **F** onto screw **D** to hold spring in place.

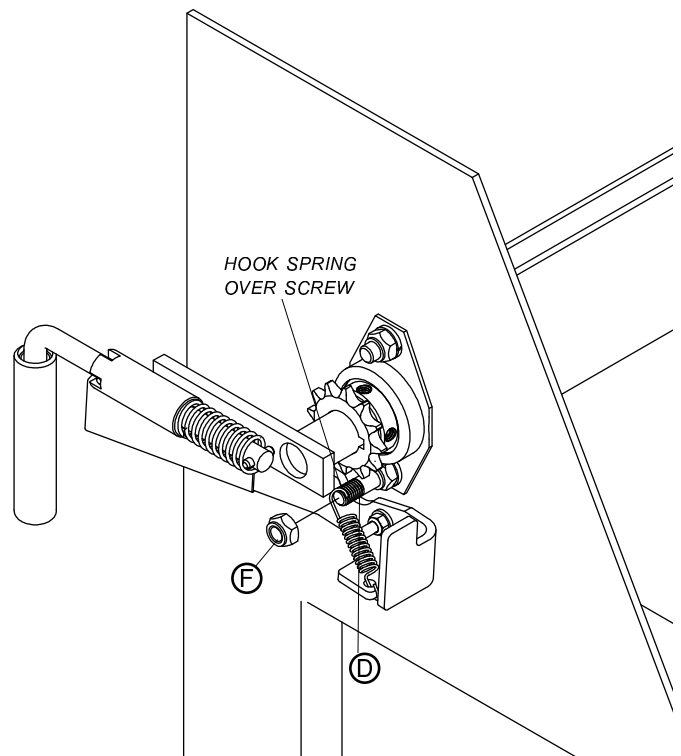

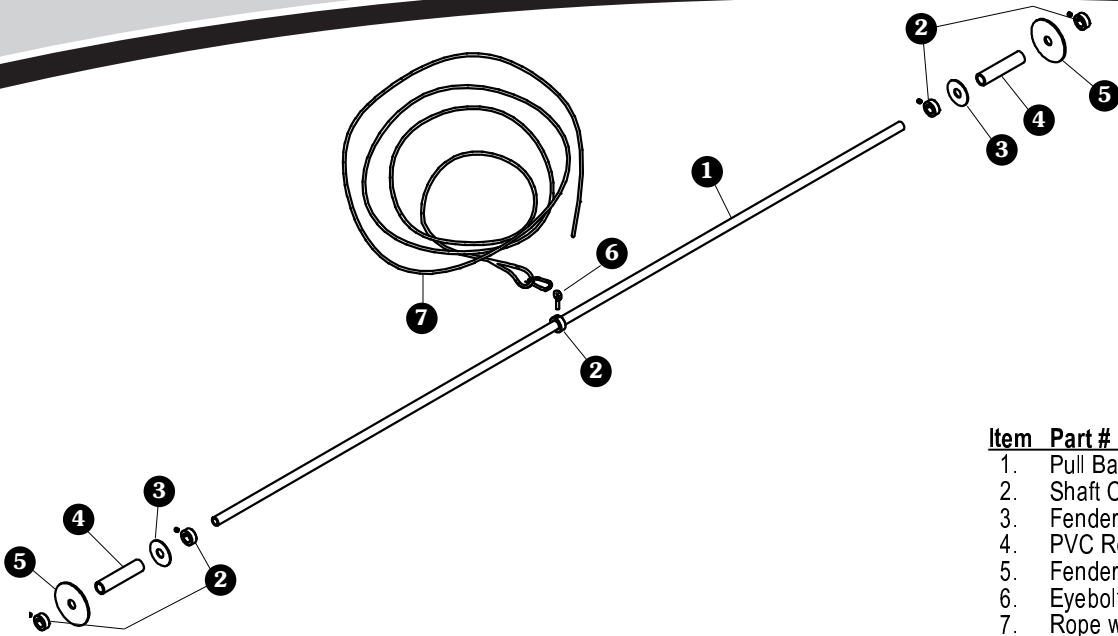

Item	Part #	Description
1.		Pull Bar Tube - 104"
2.		Shaft Collar - 1"
3.		Fender Washer - 3"
4.		PVC Roller - 1" x 6"
5.		Fender Washer - 5"
6.		Eyebolt - 5/16" x 1 1/4"
7.		Rope w/Snap

STEP 1: Slide shaft collar to center of pull bar tube and tighten set screw to secure in place.

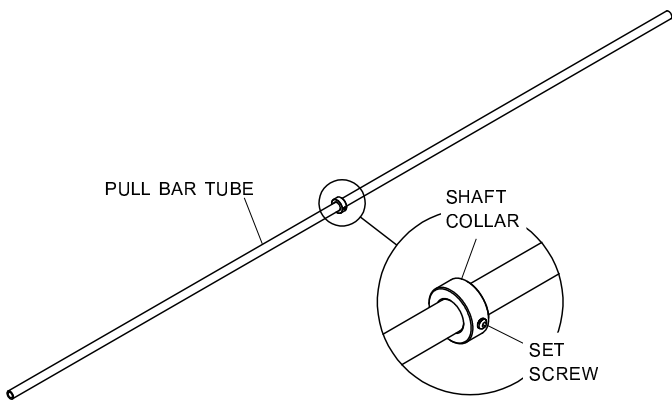

STEP 2: Insert pull bar tube into 4" pocket at rear of tarp.

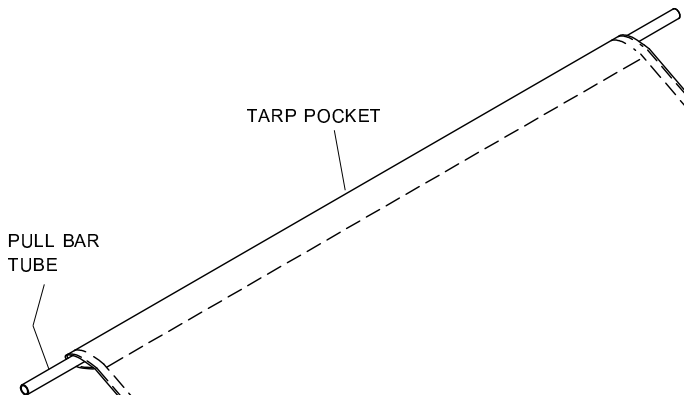

STEP 3: Slide inner shaft collars, 3" fender washers, 1" x 6" PVC rollers and 5" fender washers onto ends of pull bar. Slide outer shaft collars onto ends of pull bar tube, leaving set screw loose until final adjustment.

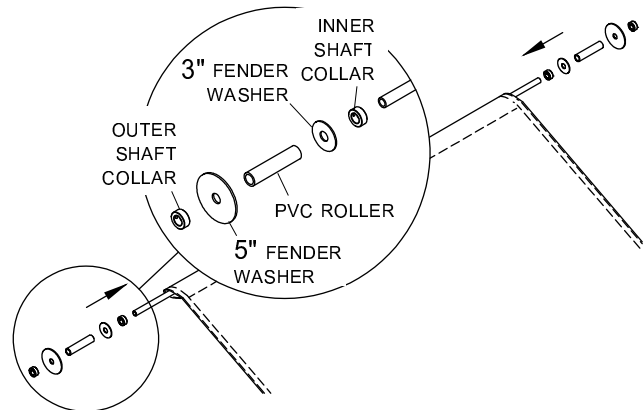

STEP 4: Measure across rear tarp pocket on tarp and mark center point on rear edge of pocket. Cut 1/4" slot at marked point in tarp pocket. Align slot with shaft collar at center of pull bar.

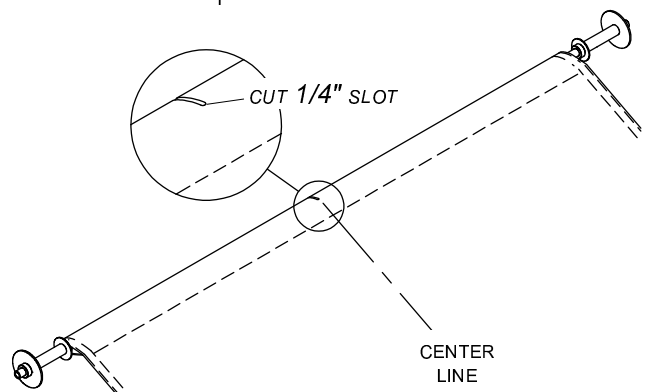

STEP 5: Remove set screw in shaft collar and replace with eyebolt. Tighten eyebolt to secure shaft collar to pull bar. Clip pull rope to eyebolt.

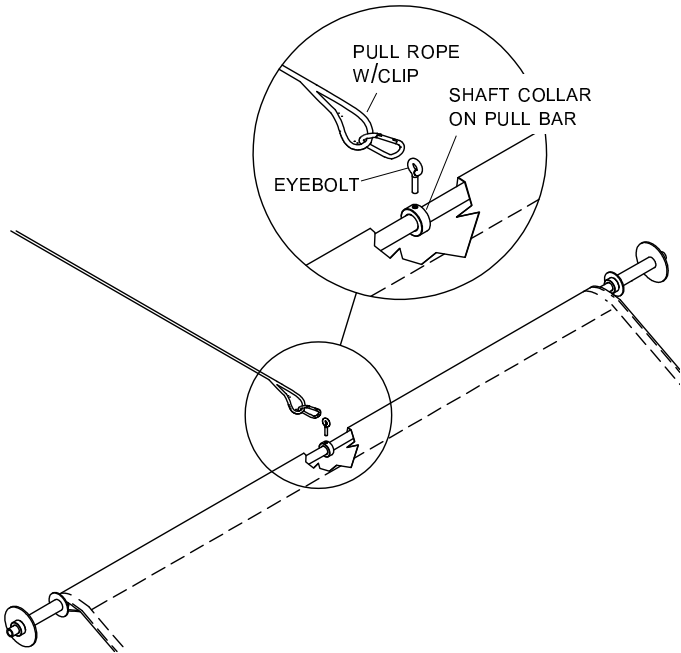

NOTE: Follow steps below to determine correct pull bar length and component placement.

STEP 6: Slide outer shaft collar on passenger side of pull bar to 1" from end of pull bar. Apply Loctite® to set screw on shaft collar and tighten.

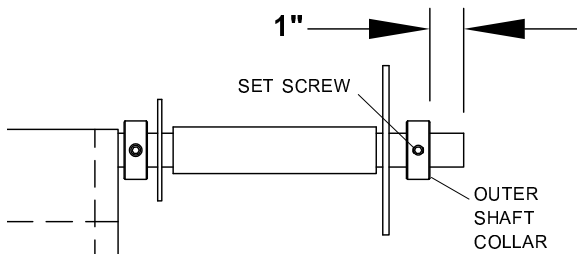

STEP 7: Slide 5" fender washer, PVC roller, 3" fender washer and 1" inner shaft collar against outer shaft collar. Apply Loctite® to set screw on inner shaft collar and tighten.

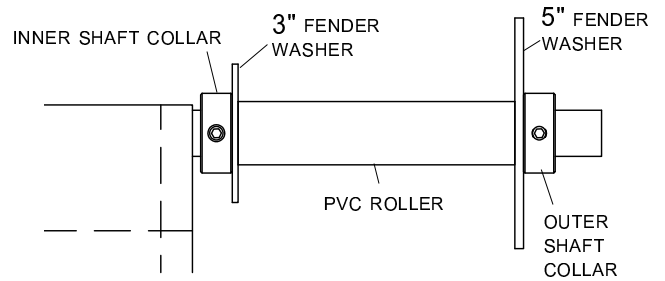

STEP 8: Center PVC rollers on top rails on both sides of trailer. Tighten set screws on shaft collars. Ensure pull bar extends at least 1" past outer shaft collar and cut off any excess length.

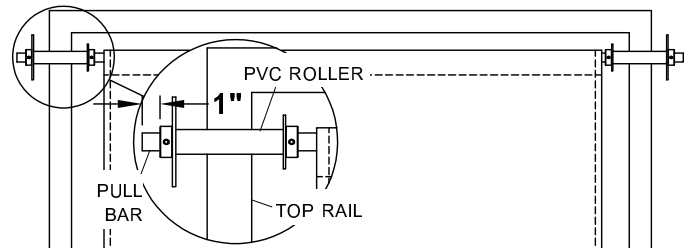

STEP 9: Loosen eyebolt on center shaft collar and center tarp on pull bar. Retighten eyebolt.

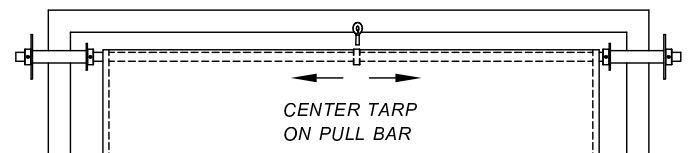

STEP 1: Locate one set of J-hooks on tailgate and another set on driver side of trailer at front. Space J-hooks far enough apart so entire length of pull rope can be stored when tarp is fully extended or retracted.

Item Description

1. J-Hook - Steel

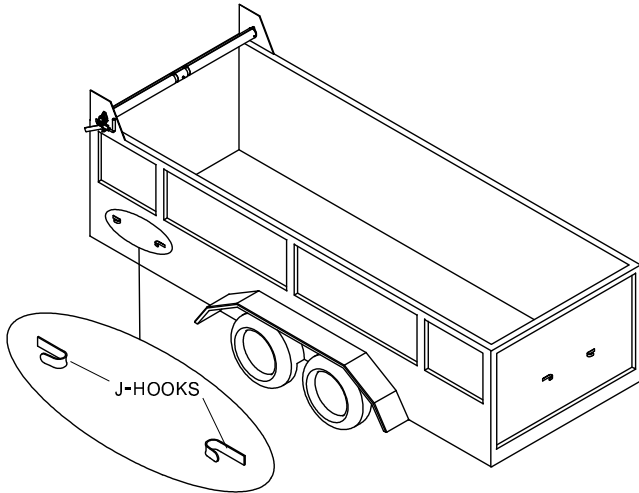

STEP 2: Weld or bolt J-hooks to trailer (fasteners not supplied).

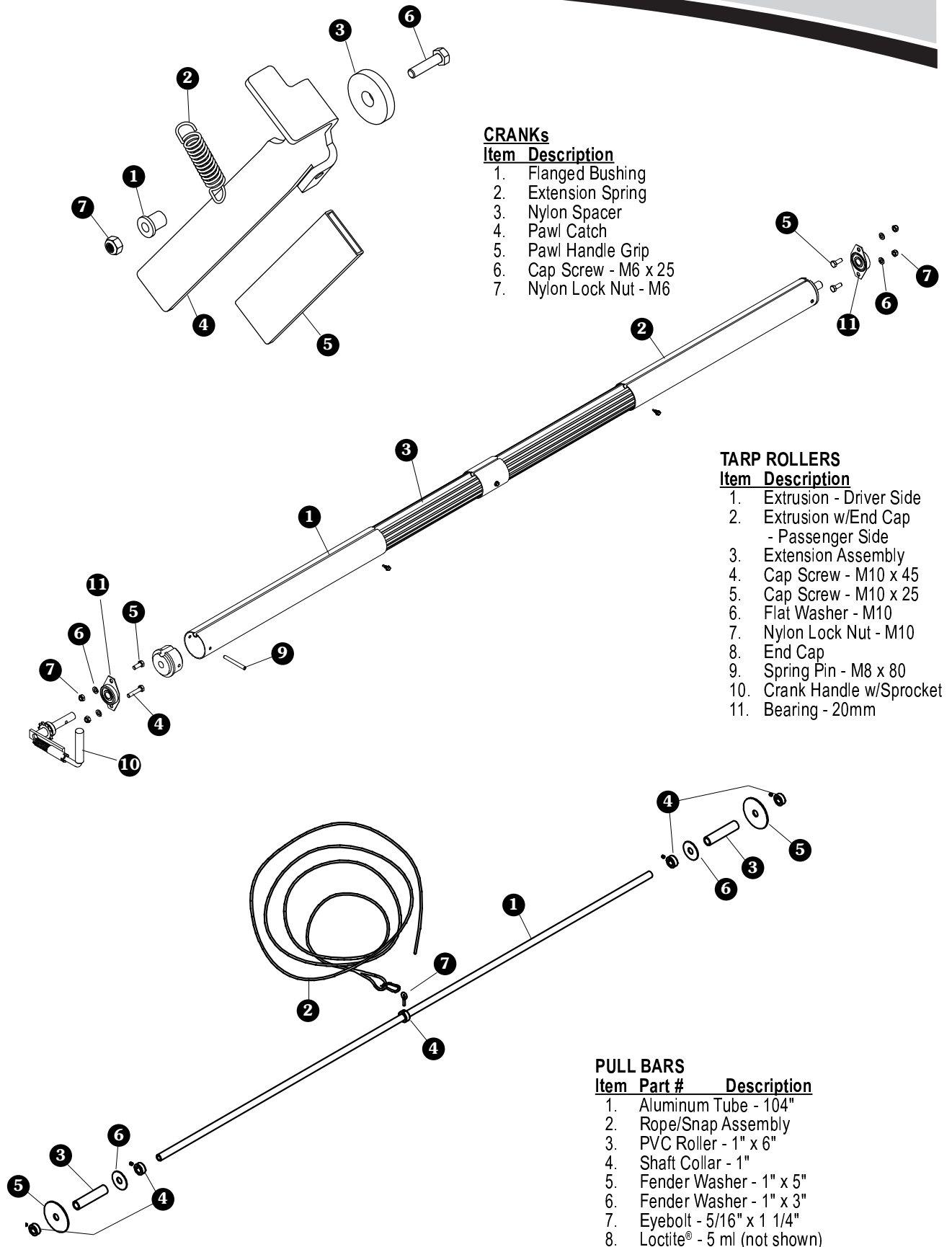

MORE QUALITY PRODUCTS FROM DONOVAN

■ Construction Products

- Arm-Matic™
- DuraPull™
- Econo-Pull™
- Turbo Tarp2™
- 2000 Series
- 5000 Series
- Hammer™
- Bullet™
- Flash™
- Long Arm™

■ Waste Products

- SWAT™
- The Ox™
- Quick-Flip III™
- Sidewinder™
- Sidewinder™ 350
- HyTower™ SL
- HyTower™ DL
- Double-Flip™
- Belt and Ratchet

TARPING SYSTEMS & ACCESSORIES

