



SHUR-LOK®

FOR GRAIN CARTS



A002FL-0620

FEATURES AND BENEFITS



- Aluminum Latchplate
- Galvanized End Caps
- Galvanized Bows/Brackets
- Recessed Tarp Stops
- 1" Ridge Strap
- Long Crank Arm w/80" Extension
- Universal Retainer Support Kit
- 18-Oz. Vinyl Tarp

This heavy-duty workhorse will outperform your expectations, offering dependable protection from the elements and superior workmanship that stands the test of time. Standard features will do the job – and do it well, but if you like to customize, we have lots of options!

Adaptable hardware lets you position the crank arm in the most efficient spot. Standoffs come in 3", 7" and 11" sizes; J-hooks are available in regular, pinless and offset-with-pin styles. Upgrade to our pinless offset retainer and eliminate pin-and-cable hassles – it secures on either side of the cart. We also offer a universal crank retainer support kit to accommodate non-vertical configurations. Our ridge straps' stretch-resistant high-tensile webbing keeps the tarp from sagging between bows. We recommend dual straps for offset placement, a larger center opening and a clear flow for loading to reduce grain splatter. For extra-wide carts with tip-top extensions, we suggest flat caps and trussed teardrop bows. The caps help shed water better while the bows facilitate tightening of the tarp. Trusses offer additional support for wide bows, where flat areas are susceptible to bending.



800.474.8756

WWW.SHURCO.COM

SHUR-LOK® BOX DETAILS For Grain Carts and Wagons

CORRECT PHYSICAL MEASUREMENTS ARE ESSENTIAL FOR PROPER TARP FIT. PROVIDE ALL REQUESTED INFORMATION OR YOUR ORDER MAY BE DELAYED. **DO NOT USE UNIVERSAL BOX SIZES. ALWAYS USE ACTUAL MEASUREMENTS.**

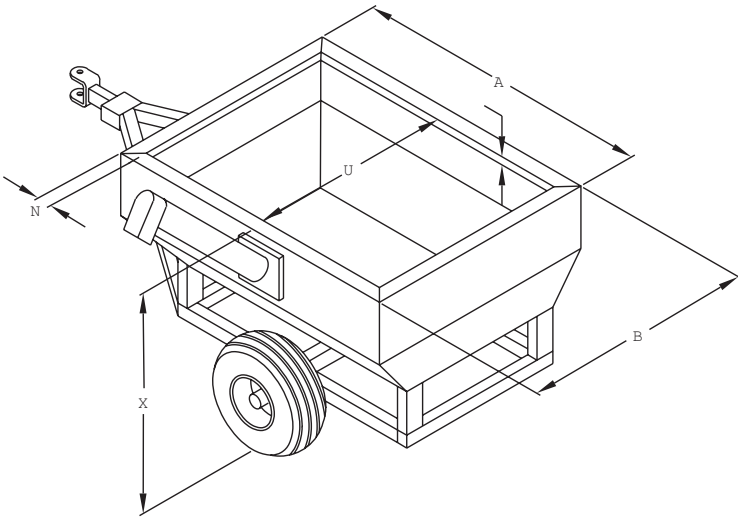

CONTACT INFORMATION

G01BD-0217

NAME _____
 ADDRESS _____
 EMAIL _____
 CITY _____ STATE _____ ZIP _____
 PHONE _____ FAX _____
 BOX/TRAILER MAKE _____
 MODEL _____ YEAR _____

BOX DIMENSIONS

A _____ UPPER OUTSIDE BOX LENGTH
 B _____ UPPER OUTSIDE BOX WIDTH
 Front _____ Center _____ Rear _____
 N _____ TOP RAIL WIDTH
 U _____ INSIDE BOX WIDTH
 X _____ UPPER OUTSIDE BOX HEIGHT

LIP IN LIP OUT

REAR CONFIGURATION *Must answer this*

VERTICAL SLOPED

BOX EXTENSION STYLE *See Figures 1 and 2*

FLAT SLANTED FLAT W/ANGLE
 SLANTED W/ANGLE SLANTED W/OVERHANG
 SLANTED W/OVERHANG AND ANGLE

BOX EXTENSION DIMENSIONS

B4 _____ EXTENSION WIDTH
 X1 _____ EXTENSION HEIGHT DRIVER SIDE
 X2 _____ EXTENSION HEIGHT PASSENGER SIDE
 X3 _____ LOWER EXTENSION ANGLE

TARP COLOR(S) _____

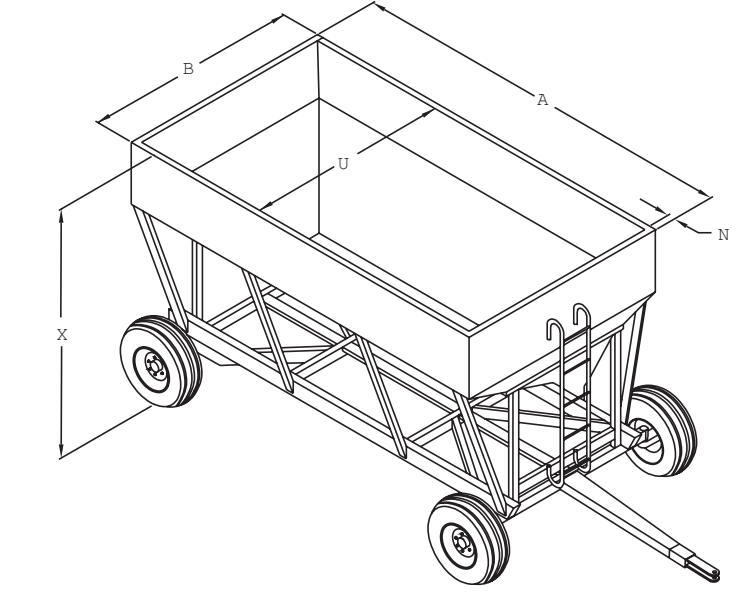
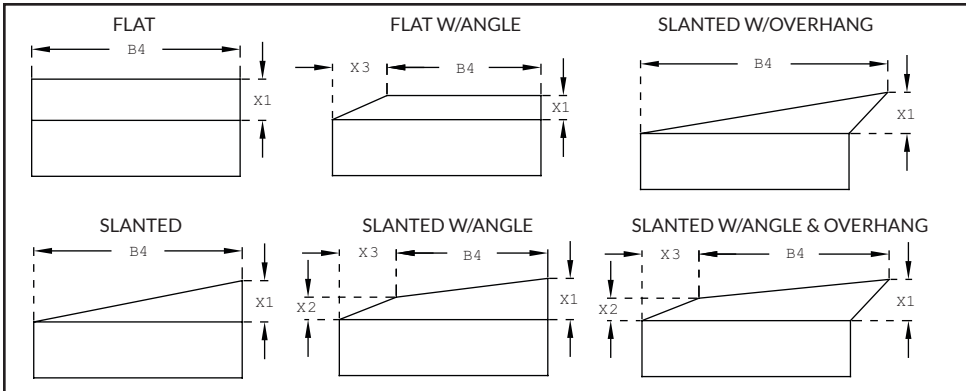
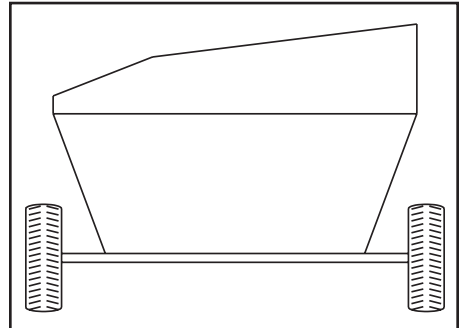

FIGURE 1



NOTE: Flat caps can ONLY be used on a SLANTED extension (see above), and the side walls MUST BE VERTICAL.

FIGURE 2



NOTE: If ordering galvanized caps, make sure box is flat across top. Figure 2 shows a box with an uneven angle across the top. Galvanized caps will NOT fit this box; you must order fabric caps instead.