



SHUR-LOK®

FOR END DUMPS



A006FL-0620

FEATURES AND BENEFITS



- High-Lift End Gates
- Shur-Flex™ Crank Arm
- Durabow™
- Turning Point™ Bow System
- Flexible Easy-Off Tarp Stop
- Stretch Cord Return
- 22-Oz. Vinyl Tarp
- Aluminum Latchplate

Shur-Lok® gives you with water-resistant dependability, for increased productivity and less downtime, because more loads mean better profits. A variety of options and upgrades help you customize your trailer to meet your individual hauling needs.

The Shur-Flex™ crank provides convenient flexibility, folding at the knuckle. The front fabric cap makes it easy to come over the top of the doghouse. Double bows secure in a double bow bracket – exactly the right spacing for tightening down the front of the tarp.

A front stretch roll return guides the roll tarp over the end cap, with a protective cover to reduce rope fraying. Reinforced stitching along the radius corner of the front fabric cap increases tear strength and helps the tarp withstand the stress of highway speeds. A rear flap, called a poorboy tail, is also available for extended coverage.



800.474.8756

WWW.SHURCO.COM

SHUR-LOK® BOX DETAILS For End Dumps

CORRECT PHYSICAL MEASUREMENTS ARE ESSENTIAL FOR PROPER TARP FIT. PROVIDE ALL REQUESTED INFORMATION OR YOUR ORDER MAY BE DELAYED. **DO NOT USE** UNIVERSAL BOX SIZES. **ALWAYS USE ACTUAL MEASUREMENTS.**

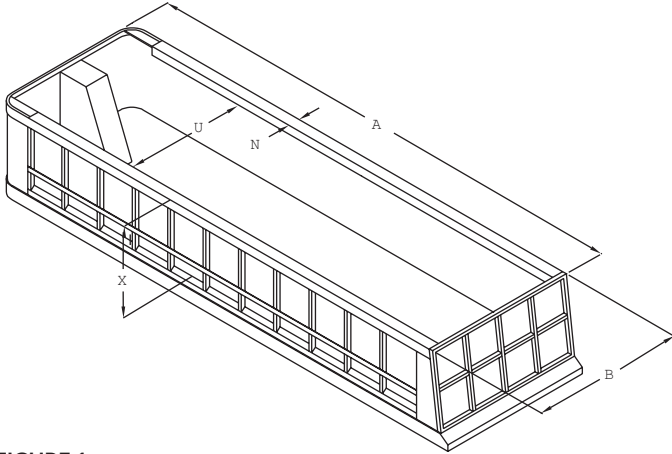

FIGURE 1

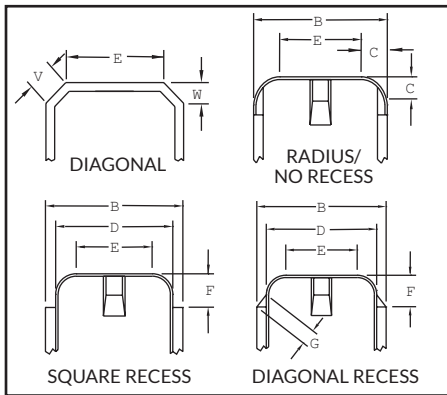

FIGURE 2

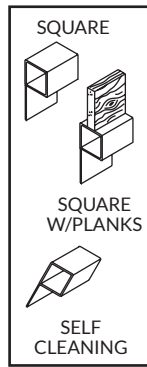

FIGURE 3

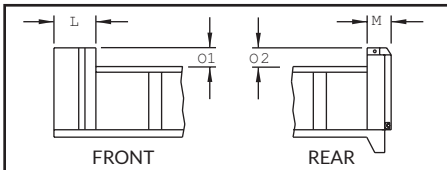

FIGURE 4

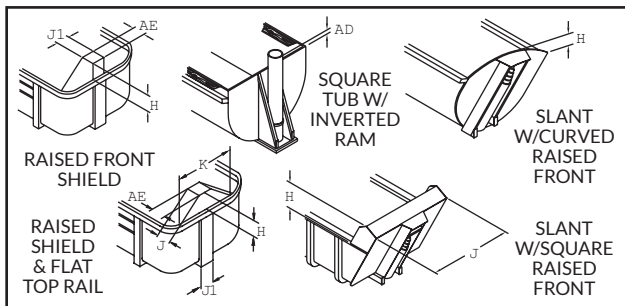
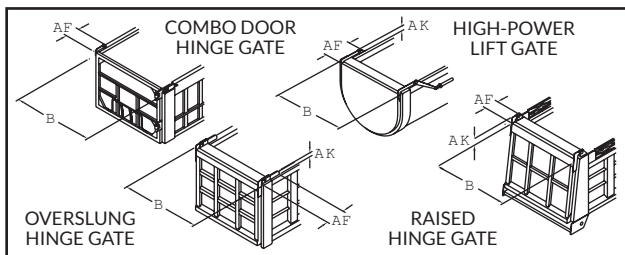

FIGURE 5



CONTACT INFORMATION

G04BD-0512

NAME _____
 ADDRESS _____
 EMAIL _____
 CITY _____ STATE _____ ZIP _____
 PHONE _____ FAX _____
 BOX/TRAILER MAKE _____

BOX DIMENSIONS

A _____ UPPER BOX LENGTH
 B _____ UPPER BOX WIDTH
 Front _____ Center _____ Rear _____
 N _____ TOP RAIL WIDTH
 U _____ INSIDE BOX WIDTH
 X _____ BOX HEIGHT

CORNER CONFIGURATION *Must select one – see Figure 1*

SQUARE DIAGONAL RADIUS/NO RECESS
 SQUARE RECESS DIAGONAL RECESS

C _____ OUTSIDE CORNER RADIUS *For all radius fronts*
 D _____ RECESSED WIDTH E _____ FLAT ACROSS FRONT
 F _____ FRONT-CORNER POST G _____ GUSSET LENGTH
 V _____ FLAT ACROSS DIAG. W _____ DIAGONAL DEPTH

TARP RAIL STYLE *See Figure 2*

SQUARE SELF CLEANING SQUARE W/PLANKS*

*Are planks flush with outside of top rail? Y / N (*Circle one*)

TARP RAIL DROP *See Figure 3* FRONT REAR

L _____ BULKHEAD DEPTH O1 _____ FRONT TOP RAIL DROP
 M _____ THRESHOLD DEPTH O2 _____ REAR TOP RAIL DROP

FRONT END STYLE *See Figure 4*

RAISED FRONT SHIELD RAISED SHIELD/FLAT TOP RAIL
 SLANT W/CURVED RAISED FRONT SLANT W/SQUARE RAISED FRONT
 SQUARE TUB W/INVERTED RAM

AD _____ CYLINDER HEIGHT J _____ UPPER SHIELD WIDTH
 AE _____ DOGHOUSE DEPTH J1 _____ DOGHOUSE WIDTH
 H _____ SHIELD HEIGHT K _____ LOWER SHIELD WIDTH

REAR DUMP STYLE *See Figure 5*

OVERSLUNG HINGE GATE COMBO DOOR HINGE GATE
 HIGH POWER LIFT GATE RAISED HINGE GATE

AF _____ HINGE DEPTH AK _____ HINGE HEIGHT
 B _____ BOX WIDTH/REAR

TARP WEIGHT

18 OZ. 22 OZ.

TARP COLOR(S) _____