



TATER-TOP™

ELECTRIC ROLL TARP



A032FL-0620

FEATURES AND BENEFITS



- Right Angle Worm Gear Motor
- Universal Mounting Brackets
- Hinged Swing Pivot Arm with Locking Rear Brace
- Front and Rear Mini “Poor Boy” Tail
- Heavy-Duty Steel Arms
- Aluminum Latchplate
- 3" Aluminum Roll Tube

The Tater-Top™ is “Loaded” with features, without utilizing hydraulic components to weigh it down. Instead, Shur-Co® uses our proven SMART technology electronics and a powerful through bore motor with a floating motor shaft for extended life. Along with our new SMARTwire connection integrated into the motor, there are no worries about any external threaded connection to corrode. It costs less and has an easier installation process. It rolls and climbs to clear heaped potato loads – no bows needed. The improved rear pivot arm swings all the way around to the side, a full 270 degrees, making sure that nothing will obstruct the rear doors. The exclusive Tater-Top™ potato box tarping system provides a secure closure.



800.474.8756

WWW.SHURCO.COM

THE SHUR-CO® DIFFERENCE

Aluminum Latchplate

The tarp snugs up under the latchplate (a design originally patented on The Original Shur-Lok® roll tarp) and a bungee in the tarp closes it tightly over the front and rear end caps.

Right Angle Worm Gear Motor

The powerful worm gear motor makes for improved clearance and requires a minimum of 12 inches between cab and box.

Hinged Swing Pivot Arm

The rear arm swings out and can be locked against the side of the box – allows operators to back into tighter confinements. The rear pivot arm swings a full 270°, so nothing will obstruct the rear doors. A fixed rear arm also available when rear door is not utilized.

SMART Electronics

Compatible with the Shur-Co® exclusive SMART3™ and SMART2™ remotes, utilizing SMART-touch "Express Mode" operation. SMARTwire is standard for the rocker switch mounted in the cab. SMARTbreaker is utilized for rocker switch in the cab applications.

Front and Rear Mini "Poor Boy" Tail

A mini "Poor Boy" tail comes standard and features a bungee that seals the front and rear of the tarp over the end caps. A choice of a standard front Shur-Lock cap is offered as well.

STANDARD FEATURES AND OPTIONS

MOTOR	
Right Angle Worm Gear Motor	Standard
RETURNS	
6-Spiral Torsion Spring per Arm	Standard
MOUNTING BRACKETS	
Universal Mounting Brackets	Standard
TORSION ARMS	
Heavy-Duty Steel Arms	Standard
LATCHPLATE	
Aluminum Latchplate	Standard
END CAPS	
Aluminum End Caps	Standard
TARP OPTIONS	
Multicolored Fabric (per added color)	Add
ACCESSORIES	
Extra SMART3™ Remote	Add
Optional Bow Kit	Add
SMARTwire™ LiteAll™ 2-Light Kit w/o Remote - SMART3™	Add
Installation Kit** - Includes 3 Bows/3 Brackets	Add
Standard Tarp Repair Kit	Add

** Supports tarp during installation process. Can also be used for display purposes.
DO NOT use for loading, hauling, etc.

Serving You Worldwide

- Service and Distribution on Six Continents -

SHUR-CO® of CANADA
Brantford, ON
1.800.327.8287

SHUR-CO® of IDAHO
Caldwell, ID
1.208.455.1046

SHUR-CO® of IOWA
Fort Dodge, IA
1.866.356.0245

SHUR-CO® of N. DAKOTA
Fargo, ND
1.877.868.4488

SHUR-CO® of S. DAKOTA
Yankton, SD
1.877.729.2969

SHUR-CO® of FLORIDA
Stuart, FL
1.800.327.8287

SHUR-CO® of ILLINOIS
Decatur, IL
1.866.356.0246

SHUR-CO® of MICHIGAN
Lexington, MI
1.800.327.8287

SHUR-CO® of OHIO
Ravenna, OH
1.866.356.0242

SHUR-CO® of UK
Rochester, Kent
1.866.689.0039



WWW.SHURCO.COM

TATER-TOP™ BOX DETAILS For Potato Trailers

ALL TARPS ARE CUSTOM-MADE TO ORDER AND ARE NON-RETURNABLE. CORRECT PHYSICAL MEASUREMENTS ARE ESSENTIAL FOR PROPER TARP FIT. PROVIDE ALL REQUESTED INFORMATION OR YOUR ORDER MAY BE DELAYED. DO NOT USE UNIVERSAL BOX SIZES. ALWAYS USE ACTUAL MEASUREMENTS. NOTE: AT THIS TIME, PRODUCT WILL NOT WORK WITH CONVEYOR BELT AUGERS.

CONTACT INFORMATION

NAME _____

ADDRESS _____

EMAIL _____

CITY _____ STATE _____ ZIP _____

PHONE _____ FAX _____

TRAILER DIMENSIONS

G13BD-0619

- A _____ OUTSIDE BOX LENGTH
- B _____ PASS TOP RAIL WIDTH
- C _____ FRONT TOP RAIL WIDTH
- D _____ PASS RIB DISTANCE
- E _____ OUTSIDE BOX WIDTH
- F _____ DOOR REAR WALL WIDTH
- G _____ REAR DOOR WIDTH
- H _____ PASS REAR WALL WIDTH
- I _____ PASS SIDE WALL HEIGHT
- J _____ REAR DOOR HEIGHT
- K _____ FRONT WALL OBSTRUCTIONS (MEASURE HOW FAR OUT THESE EXTEND)

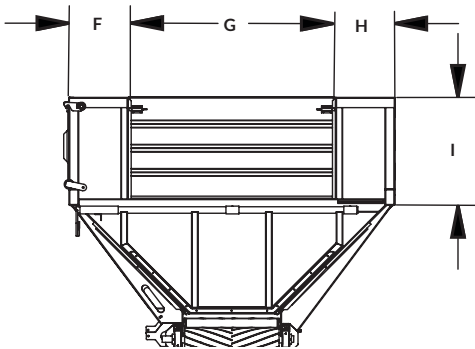
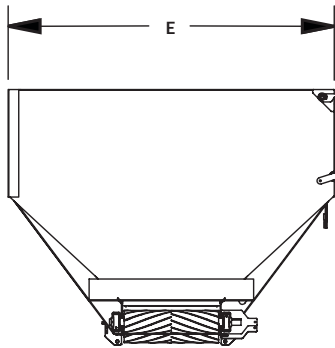
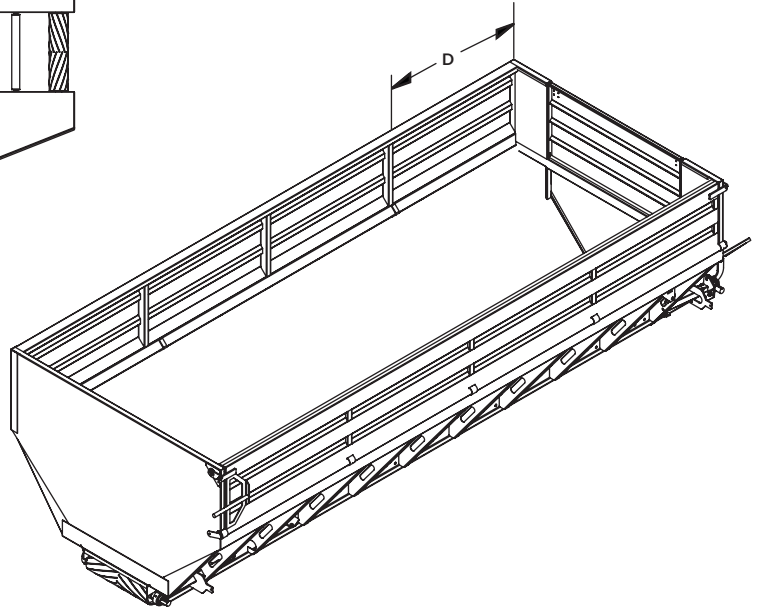
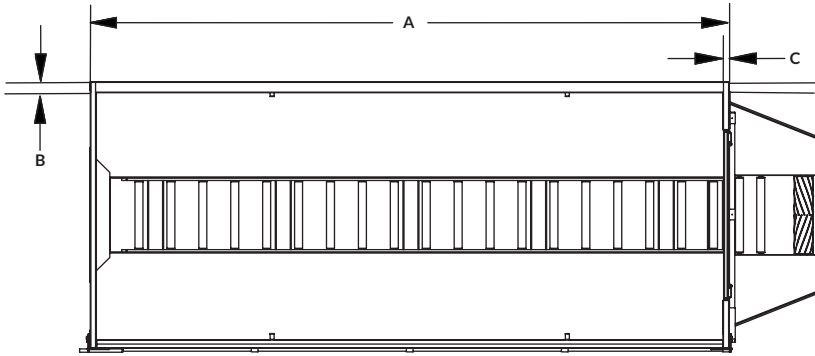

ADDITIONAL INFORMATION NEEDED

- FIXED REAR GATE FOLD-IN WALL

- _____ CATWALK HEIGHT (MEASURE TOP OF GATE TO TOP OF CATWALK)
- _____ LADDER PLATFORM HEIGHT (MEASURE TOP OF GATE TO TOP OF CATWALK)

Fax 605.665.0501

Salesperson _____