



THE COMPLETE SMARTRAILER™ LINE

SHURCO.COM

Shur-Co® History	pgs. 2-3
SMARTrailer™ Electrics	pg. 4
SMART2™ and SMART3™ Remotes	pg. 5
Shur-Lok® Electric	pg. 6
4500 Series HD Electric Tarp	pgs. 7-13
Tater-Top™ Electric Tarp	pgs. 14-15
AutoTrap™ and ProTrap® Hopper Openers	pg. 16-17
DriveMaxx™ Auger Drive Kit	pg. 18
Electric Gate and Hoist System	pg. 19
AutoGate™ Gate Runner	pg. 20
Electric Turning Point™ Bow System	pg. 21
TrapAdapt™ Manual Trap Opener	pg. 22
LiteALL™ LED Work Light Packages	pgs. 23-24
SMARTwire™	pgs. 25-31
Electric Systems Order Forms	pgs. 32-36
Genuine Shur-Co® Replacement Parts	pgs. 37-60
Terms and Conditions	pg. 61
NEW! Service Truck Power Kits	pgs. 62-63

ELECTRICS PRODUCT GUIDE

WHAT OUR CUSTOMERS SAY

“ One of the reasons I wanted to go with a 4500 Series HD electric roll tarp was because I felt that, with the down pressure from the spring-loaded arms, it would be better in windy conditions during field use, and it has not disappointed. With the down pressure on both the front and rear, it handles wind much better than a manual roll tarp. Besides the convenience, there is also a time savings factor. The driver can roll over the tarp as he is pulling out of a field and unroll it as he is pulling onto a scale. Over a season, this adds up, especially during harvest. We went with the Shur-Co® 4500 HD because of the heavy-duty design, overall quality, reputation of the company and the close vicinity of a local dealer. I also really enjoy the programmable wireless remote. No regrets.”

– Harry Jiles, Jiles Farms, Inc., Arrowsmith, IL

“ It's like I'm always telling my customers, 'Buy the best or I'll fix the the rest.' Whenever someone asks for my recommendation, I say, 'Put on a Shur-Co®; you won't be back for repairs.' Then I say, 'But I'll be glad to fix the other brands – it's up to you.' Also, my customers love the ease and convenience of your SMARTrailer™ electric accessories!”

– Tim Harms, President, Harms Trucking Co., Minooka, IL

“ I am very impressed with the ease of installation and operation of the SMART2™ remote. I like the idea of having a charging unit on it. The ease of programming is so simple, especially with the one-touch (SMART-touch) open and close. The digital display makes it very simple for the customer to learn the operation . . . I am also impressed with the clean design. In my opinion, you have the best product in its market!”

– Bryan Kelchen, Buckshot Repair, La Porte City, IA

“ The 4500 Series HD electric roll tarp is easy to install and has been a durable product. It gives me the peace of mind I need in the field on days when the wind is blowing.”

– Jamie Jackson, Egeland, ND

“ Shur-Co's 4500 Series HD electric roll tarp is hands down the best I have ever used. The installation was easy, and the instructions are straightforward.”

– Stan Sunderman, Sunderman Farms, Otis, CO

“ I have two of Shur-Co's 4500 Series HD electric roll tarps. Like many things, a luxury once enjoyed becomes a necessity. It took me one time to use the system to know how much work and time this was going to save. Most elevators want the tarp rolled back before you pull on the scale. I feel sorry for the guys that still have to stop to get out before pulling on the scale. And do I even have to mention rainy days or fighting a tarp on a windy day? I'll never live without an electric tarp again.”

– Tom Roberts, Roberts Enterprises, LLC, New Ulm, MN

“ I have bought five 4500 Series HD electric roll tarps in the last three years, and it is a great product with easy installation. I have had no problems whatsoever. The systems even work well in the winter when the tarps are cold and stiff!”

– Jarrod Robertson, Robertson Farms, Elkton, KY

“ I had a Shur-Co® electric tarp put on my 48-foot Wilson hopper trailer because I didn't want my tarp blown off when it's windy. I also had it put on to conserve time. Whether I'm loading or unloading my trailer, I can close or open my tarp with no delay when I am driving to a probe or back to a scale. It saves me a considerable amount of time. I would recommend a Shur-Co® 4500 Series HD electric roll tarp to anyone with a hopper trailer.”

– Nathan Nelson, Owner/Operator, Double N Transport, Page, ND

If you have comments on Shur-Co® products, please send them to Shur-Co® Marketing, 2309 Shur-Lok St., Yankton, SD 57078.

COMPANY TIMELINE

- 1954 A shoe repair shop opens in Wahpeton, ND, moves into tarp repair and then new tarps.
- 1969 Growing tarp demand results in the creation of Wahpeton Canvas Company (WCCO).
- 1980 *The Original Shur-Lok®* roll tarp is born. The simple, yet reliable invention revolutionizes the tarping industry.
- 1992 The truck cover division of the company splits off from WCCO and relocates to Yankton, SD.
- 1996 A name change to Shur-Co® more closely identifies the company with the Shur-Lok®, its best-known product.
- 2000 Shur-Co® enters the auto accessories field with its TruXedo® line (to be spun off as its own company in 2007 under new ownership).
- 2001 Acquisition is made of a highly automated metal fabrications operation.
- 2003 Shur-Co® is named South Dakota's Family Business of the Year.
- 2006 Shur-Co® moves into trailer automation with the launch of the 3500 Series electric upgrade for the Shur-Lok®. Like the introduction of the Shur-Lok® itself, 40 years ago, the 3500 is unlike anything in the electric tarp market.
- 2008 State-of-the-art expansion allows Shur-Co® to keep up with increasing product demand, bringing the company's total manufacturing area to 150,000 square feet.
- 2009 The ProTrap® electric hopper opener and five-channel SMARTransmitter® are launched to complement the 3500, for an expanded line of SMARTrailer™ products.
- 2010 Shur-Co®, LLC is formed with the existing management team, sparking unprecedented growth and global market expansion.
- 2012 More products join the Shur-Co® lineup: SMART2™ and SMART1+™ remotes, 4500 Series HD electric tarp, LiteALL™ work lights, DuraPull™ semi-auto pull tarp and IronSide™ side dump system. Later in the year, Shur-Co® acquires Donovan Enterprises, a top name in waste and construction tarp systems, with locations in Michigan, Florida and the UK – positioning Shur-Co® for global growth.
- 2014 Roll-Tite™ is acquired and rebranded as ShurTite™ – an industry-leading retractable tarp system for flatbed trailers, dropdecks, straight trucks and specialty vehicles.
- 2015 Global expansion continues as Shur-Co® sells products to over 30 countries on 6 continents.
- 2016 Growth continues as a branch dedicated to ShurTite™ installs and repairs opens in Sioux Falls, SD. Shur-Co® of ND moves into a new 24,000 square foot facility in West Fargo. Shur-Co® of IL relocates to a new 16,000 square foot facility in Decatur.
- 2017 Shur-Co® rolls out its SWAT® system for roll-off trucks and trailers in the waste market and the Tater-Top™ roll tarp for potato trailers. The company also celebrates 25 years in its Yankton, SD location.
- 2018 Shur-Co's continued focus on innovation adds additional products to its SMARTrailer™ line: the Electric Gate and Hoist and DriveMaxx™ Swing Auger Drive Kit.
- 2019 Shur-Co® opens a branch in Caldwell, Idaho. Shur-Co® adds the 4500 HD for grain cart applications, the AutoGate™ Gate Runner, TrapAdapt™ Manual Hopper Opener and Service Truck Power Kits.
- 2020 The Sioux Falls & Iowa operations are consolidated to new full-service branch located in Vermillion, SD.



SUPERIOR MATERIALS AND WORKMANSHIP

Shur-Co® proudly serves our customers with 10 sales, service and distribution locations throughout North America, plus an ever-expanding global presence. We have the best-designed, best-engineered and best-built tarping systems on the market.

Our 150,000 square foot production site has its own dedicated tarp and metal fabrication facilities, giving us complete control over the products we produce. Exacting workmanship is key; our employees have a strong Midwest work ethic and are willing to go the extra mile to provide customers with a superior-quality product. They take pride in their jobs, and their dedication and attention to detail has earned us the respect of the tarping industry.

Shur-Co® never cuts corners. For our tarps, we use the finest solid vinyl-coated fabric with built-in UV inhibitors to reduce sun damage and fading. Each lot is lab tested for tear strength, abrasion resistance and cold-temperature flexibility.

Shur-Co® quality shows, even in the smallest details: Reinforced stitching adds strength at stress points, reducing the likelihood of tears. Seams are heat welded for a watertight bond between panels; the added thickness creates an improved moisture barrier. Roll tubes, fixed tubes and bows are made from Gatorshield™ galvanized steel tubing, with 50 percent more zinc than standard galvanized processes, ideal for high-moisture applications. All other steel components are plated to stand up to harsh road treatment chemicals. Aluminum, stainless steel and powder-coated parts are also available – and many come standard – when added protection is needed for corrosive environments.



THE NEW AGE OF TRAILER AUTOMATION

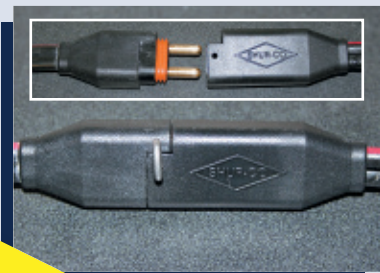
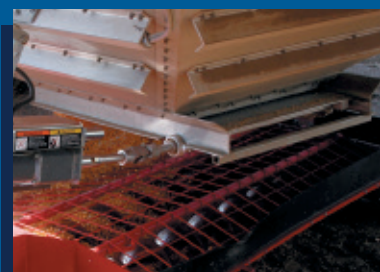

THE SMARTTRAILER™ LINE

SMARTrailer™ electrics help you do the job faster, easier and with increased productivity – even the install is simple. Tarps, traps and box gate and hoist all come standard with a sealed control box and quick-connect sealed SMARTwire™ harness – a Shur-Co® exclusive.

Our SMARTrailer™ electric accessories are designed to prevent corrosion of connectors and reduce installation time. Sealed connections mean that no additional wire stripping or crimping is required. You get plug-and-play convenience, plus a 12-volt tap to supply power for LiteALL™ work lights. The patented SMARTwire™ harness has molded rubber connectors and silicon seals, 1/4-inch brass pins and sockets and dual 6-gauge wiring.

Additional design features also contribute to faster installs. The mounting bracket for the 4500 HD matches your trailer's rib-and-rivet spacing. The ProTrap® comes fully assembled.

The SMARTrailer™ line of electrics can be operated with Shur-Co's SMART2™ or SMART3™ remotes. These state-of-the-art transmitters provide precise control from the safety and comfort of the cab to boost your productivity and end results.

SMARTrailer™ Products: SMART2™ and SMART3™ Remotes, Shur-Lok® Electric, 4500 Series HD Electric Tarp, AutoTrap™ Electric Hopper Opener, ProTrap® Electric Hopper Opener, Electric Gate and Hoist System, DriveMaxx™ Auger Drive Kit, Tater-Top™ for Potato Trailers, AutoGate™ Gate Runner, Electric Turning Point™ Bow System, TrapAdapt™ Manual Hopper Opener, Lite-ALL™ LED Work Lights and Service Truck Power Kits.



SMART₂[™] AND SMART₃[™] REMOTES

SMART-touch technology for the most precise control on the market today! The SMART₂[™] remote offers industry-leading 2-way communication in an easy-to-read digital display. The SMART₃[™] has a popular, simple-to-use 5-channel interface, *plus* additional features.

These remotes operate the 4500 Series HD, AutoTrap[™] and ProTrap[®], Gate and Hoist system, DriveMaxx[™] auger drive, Tater-Top[™] system, AutoGate[™] gate runner and LiteAll[™] LED work lights. They provide advanced motor protection – you know right away if a motor slows or stalls – and make operation safe and easy! Transmitters have an emergency shut-off; close the flip-style lid – whatever is running stops immediately.

The SMART₂[™] senses and displays over 100 devices, relaying real-time positioning of tarps and traps. Constructed of impact-resistant ABS plastic, it features a 2-1/2-inch digital screen that's backlit for night operation. This remote doesn't just open or close chosen applications, it lets you specify exact positioning. Automatically open tarps away from the stops to save on wear and tear and maintenance. Or open traps based on capacity of the elevator pits.

The SMART₃[™] is simple to use – switch between applications with the Select button, only cycling between those you've installed. Plus, you get increased range and Express Mode capabilities. The AAA battery compartment lid removes with a single screw for easy access.

Key Features: SMART₃[™] Remote w/AAA Batteries (2). SMART₂[™] Remote w/Rechargeable Lithium Battery, Charging Cradle, 12-Volt Automotive-Style Charging Cable.

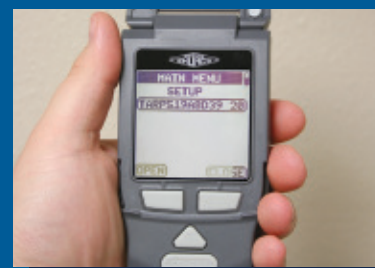

THE LIGHT-DUTY MOTOR OPTION



SHUR-LOK® ELECTRIC / CABLE-LOK™ ELECTRIC

The Shur-Lok® Electric accommodates existing Shur-Loks and Cable-Loks on sloped or vertical trailers and boxes, works with minimum clearance and is easy to install. The light-duty Durabuilt™ motor offers manual override capability and mounts on either the front or rear.

Works on bodies up to 34 feet long. Equipped with a front and rear bungee return (cable return upgrade available) and durable steel components, it can be installed up against the box to handle tight clearances between cab and body. It comes in galvanized steel or stainless steel for added corrosion resistance, with applications for farm boxes with hoist, grain trailers and fertilizer tenders.

The versatility of having a light-duty motor option allows you to better fit your trailer size and configuration. Proper motor choice can affect how much tension your tarp creates over the bows and end caps when in the closed position. This impacts wind flutter control and tarp wear and can also affect how the tarp rolls and handles stresses during operation.

Key Features | Rocker Switch: Durabuilt™ Motor, Wire or SMARTwire™ w/Dual-Conductor Plug, Switch, Solenoid, Breaker, Arm, Bungee Return.

Key Features | SMART Remotes: Durabuilt™ Motor, SMARTwire™ w/Dual-Pole Plug, Switch, Solenoid, Breaker, Arm, Bungee Return, SMART2™ or SMART3™ Wireless Kit.

NOTE: SMART remotes will NOT operate in Express Mode.

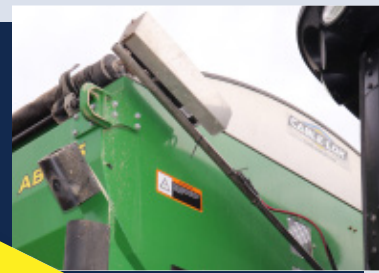

The SMARTdrive™ motor was designed for use with our Cable-Lok™ and Shur-Lok® tarp systems in the fertilizer industry. The SMARTdrive™ utilizes Shur-Co's exclusive SMARTwire™, which features 100% sealed connections and eliminates crimped ends, ring terminals, premature motor failure, and wire corrosion.



4500 SERIES HD FOR TRAILERS AND END DUMPS

Power for your grain trailers, end dumps and live bottoms! American-made motor with all-metal gearbox and reliable magnetic brake moves heavy-duty aluminum torsion arms with spiral-reinforced elbows. Designed with the range and flexibility to move smoothly over loads.

Available for all trailer makes and models! The 4500 Series HD produces optimal rather than increased torque, so it won't harm your tarping system. A patented dual-pivoting motor mount allows for any misalignment of the roll tube without stress to the system.

Heavy-duty arms are the strongest in the industry, backed with a lifetime warranty against breakage. Arms come preassembled with a sturdy mounting bracket and are inset to prevent obstruction of clearance lights. The low-friction roller bearing-style rear arm bracket won't wear out. An additional GateFlex™ joint bypasses hinges to accommodate tailgates.

Key Features | Grain Trailer: 4-Spiral Torsion Springs per Arm, Heavy-Duty Rear Cable Return w/Single-Arm Series, Heavy-Duty Aluminum Brackets, Heavy-Duty Aluminum Arms, Cab Wiring Kit for Standard Electric Hardware or Trailer Wiring Kit for SMARTwire™ Systems, Exposed Spline, SMART2™ or SMART3™ Remotes,

Key Features | End Dumps and Live Bottoms: 4-Spiral Torsion Springs per Arm, Shur-Strap™ or Heavy-Duty Rear Cable Return w/Single-Arm Kits, Heavy-Duty Aluminum Brackets, Rear Knife-Gate Beam Bracket w/Knife-Gate Trailers, Heavy-Duty Aluminum Arms, Cab Wiring Kit for Standard Electric Hardware or Trailer Wiring Kit for SMARTwire™ Systems, Gate Flex™ w/Double-Arm Kits, Exposed Spline w/Single-Arm Kits w/Shur-Strap™.



In the chart at right, features that come standard for Grain Trailers are indicated, but you can also see what options are available for this application in each category.

The plus sign (+) indicates that it would be an additional cost, a minus sign (-) lets you know it would cost less than standard and N/C indicates no difference in price.



4-SPIRAL TORSION SPRING

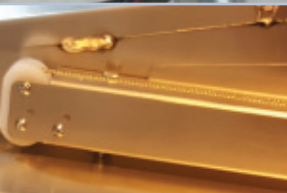

HEAVY-DUTY REAR CABLE RETURN



HEAVY-DUTY ALUMINUM BRACKET

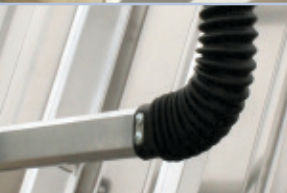

HEAVY-DUTY ALUMINUM ARM



PATENTED SMARTWIRE™



EXPOSED SPLINE



CRANK RETAINER



SMART 3™ REMOTE

STANDARD FEATURES AND OPTIONS

RETURNS	
● 4-Spiral Torsion Springs per Arm	Standard
● HD Rear Cable Return - Standard w/Single-Arm Kits w/Alum. Caps	
MOUNTING BRACKETS	
● Heavy-Duty Aluminum Brackets	Standard
TORSION ARMS	
● Heavy-Duty Aluminum Arms	Standard
WIRING	
● Cab Wiring Kit (6 Ga.) - Standard w/30' Wire/Electric Hardware	
● Trailer Wiring Kit (6 Ga.) - Standard w/SMARTwire™	
Cab Wiring Kit (6 Ga.)* - Existing w/SMARTwire™	Deduct
Cab Wiring Kit (6 Ga.)** - Cab Wiring Only	Deduct
Trailer Wiring Kit *** - Existing w/o SMARTwire™	Add
SPLINE CAPABILITY	
● Exposed Spline	Standard
REMOTE	
No SMART2™****	Deduct
No SMART3™****	Deduct
A TRAIN SETUP - LEAD/PUP	
● Lead Wiring Kit (4 Ga.) w/SMARTwire™	Standard
● Coiled Wire (4 Ga.) w/Dual-Conductor Plug - 15'	Standard
Coiled Wire (4 Ga.) w/Dual-Conductor Plug - 20'	Add
ACCESSORIES	
Crank Retainers**** - P/N 1101929 (2 are required)	Add/Ea.
Extra SMART3™ Remote	Add
SMARTwire™ 2-Light Kit w/o Remote - SMART3™	Add
SMARTwire™ 2-Light Kit w/o Remote - SMART2™	Add

*Existing cab wiring MUST have been purchased from Shur-Co®. Deduction ex-cludes cab wiring kit and SMARTwire™ dual-conductor socket. Includes SMART-wire™ junction block with plug for quick-connect install.

**Existing cab wiring kit MUST have been purchased from Shur-Co®. Deduction ex-cludes cab wiring kit ONLY.

***Includes junction box and junction block for wiring non-SMARTwire™ system to SMARTwire™ system.

****If SMART2™ or SMART3™ accessories are already on trailer, no remote needed.

*****Used to store crank arm.

STANDARD FEATURES AND OPTIONS

RETURNS	
● 4-Spiral Torsion Springs per Arm	Standard
● Shur-Strap™ – Standard w/Single-Arm Kits	
● Heavy-Duty Shur-Return™*	
● Shock Cord Roll Return*	
MOUNTING BRACKETS	
● Heavy-Duty Aluminum Brackets	Standard
TORSION ARMS	
● Heavy-Duty Aluminum Arms	Standard
WIRING	
● Cab Wiring Kit (6 Ga.) – Standard w/30' Wire/Electric Hardware	
● Trailer Wiring Kit (6 Ga.) – Standard w/SMARTwire™	
● Cab Wiring Kit (6 Ga.)** – Cab Wiring Only	Deduct
SPLINE CAPABILITY	
● Gate Flex™ – Standard w/Double-Arm Kits	
● Exposed Spline – Standard w/Single-Arm Kits w/Shur-Strap™	
● Manual Override Kit – For Kits w/Over 2" Hinge Depth	Add
ACCESSORIES	
● Easy-Off Tarp Stop - 6" Offset P/N 1124783	Add/Ea.
● Additional 25' (4 Ga.) SMARTwire™ – For 100' Total***	Add
● Extra SMART3™ Remote	Add
● SMARTwire™ 2-Light Kit w/o Remote - SMART3™	Add
● SMARTwire™ 2-Light Kit w/o Remote - SMART2™	Add

*Optional return for single-arm series.

**Includes junction box and junction block for wiring non-SMARTwire™ system to SMARTwire™ system.

***Needed for framed trailers 34' or longer.

In the chart at left, features that come standard for End Dumps and Live Bottoms are indicated, but you can also see what options are available for these applications in each category.



4-SPIRAL TORSION SPRING



SHUR-STRAP™ RETURN

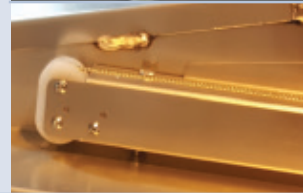

HEAVY-DUTY REAR CABLE RETURN



HEAVY-DUTY ALUMINUM BRACKET



REAR KNIFE-GATE BEAM BRACKET



HEAVY-DUTY ALUMINUM ARM



GATE FLEX™



EXPOSED SPLINE

STANDARD FEATURES AND OPTIONS

RETURNS	
● 4-Spiral Torsion Springs per Arm	Standard
● Shur-Strap™ – Standard w/Single-Arm Kits w/Fabric Caps	
● HD Rear Cable Return – Standard w/Single-Arm Kits w/Alum. Caps	
MOUNTING BRACKETS	
● Heavy-Duty Aluminum Brackets	Standard
● Rear Knife-Gate Beam Bracket – Standard w/Knife-Gate Trailers	
TORSION ARMS	
● Heavy-Duty Aluminum Arms	Standard
WIRING	
● Cab Wiring Kit (6 Ga.) – Standard w/30' Wire/Electric Hardware	
● Trailer Wiring Kit (6 Ga.) – Standard w/SMARTwire™	
● Cab Wiring Kit (6 Ga.)* – Cab Wiring Only	Deduct
SPLINE CAPABILITY	
● Gate Flex™ – Standard w/Double-Arm Kits	
● Exposed Spline – Standard w/Single-Arm Kits w/Shur-Strap™	
● Manual Override Kit – For Kits w/Over 2" Hinge Depth	Add
ACCESSORIES	
● Easy-Off Tarp Stop - 6" Offset P/N 1124783	Add/Ea.
● Extra SMART3™ Remote	Add
● SMARTwire™ 2-Light Kit w/o Remote - SMART3™	Add
● SMARTwire™ 2-Light Kit w/o Remote - SMART2™	Add

*Existing cab wiring kit MUST have been purchased from Shur-Co®. Deduction excludes cab wiring kit ONLY.

FAST, EASY WAY TO PROTECT THE HARVEST



4500 SERIES HD FOR GRAIN CARTS

The 4500 Series HD works as an application for existing Shur-Loks on grain carts. Reliable motor with all-metal casing and patented dual-pivoting motor mount operate heavy-duty aluminum arms – the strongest on the market, with a lifetime guarantee against breakage.

Super-strong tension arm opens and closes the tarp with smooth, consistent tension. Our exclusive dual-pivoting Durabuilt™ motor mount allows for any misalignment of the roll tube without stress to motor or arm. Arm is easily moved by 4-spiral torsion springs, and heavy-duty front cable return is included with single-arm series.

Key Features: 4-Spiral Torsion Springs, Heavy-Duty Front Cable Return, Heavy-Duty Aluminum Bracket, Heavy-Duty Aluminum Torsion Arm, Tractor Cab Wiring Kit for Standard Electric Hardware or Trailer Wiring Kit for SMARTwire™ Systems, 90° Worm Gear Durabuilt™ Motor, SMART3™ Remote.



STANDARD FEATURES AND OPTIONS

RETURNS	
4-Spiral Torsion Springs per Arm (6 Springs for HD Kit)	Standard
Heavy-Duty Front Cable Return	Standard
MOUNTING BRACKETS	
Heavy-Duty Aluminum Brackets	Standard
TORSION ARMS	
Front/Rear Aluminum Heavy-Duty Arms	Standard
WIRING	
Tractor Cab Wiring Kit (6 Ga.) – Standard w/30' Wire/Electric Hardware	
Trailer Wiring Kit (6 Ga.) – Standard w/SMARTwire™	
MOTORS	
90° Motor - For Carts Up to 144" Wide and 24' Long	Standard
HD Parallel Shaft Motor - For Any Size and Width Cart	Standard
REMOTE	
SMART3™	Standard
ACCESSORIES	
Crank Retainers** P/N 1101929 (2 are required)	Add/Ea.
Extra SMART3™ Remote	Add
SMARTwire™ 2-Light Kit w/o Remote - SMART3™	Add

**Used to store crank arm.

In the chart at left, features that come standard are indicated, but you can also see what options are available for this application in each category.

4-SPIRAL TORSION SPRING



HEAVY-DUTY FRONT CABLE RETURN



HEAVY-DUTY ALUMINUM BRACKET



HEAVY-DUTY ALUMINUM ARM



PATENTED SMARTWIRE™



90° WORM GEAR MOTOR



CRANK RETAINERS



SMART3™ REMOTE



KEEPS MATERIALS CONTAINED



4500 HD FOR OTVS, CHIP AND REFUSE TRAILERS

The 4500 Series HD is easy to install, accommodating sloped or vertical trailers and boxes. Its powerful American-made motor and super-strong extruded aluminum arms withstand the rigors of loading and unloading heavy bulk materials like scrap, recyclables and waste.

When you haul heavy-bulk materials like wood chips, scrap, recyclables or refuse, preventing load loss with a Shur-Lok® or PBR tarping system only makes sense, and a 4500 Series HD makes tarping convenient as well as practical. Experience the security of tarping without having to climb on the trailer.

Single arm returns should be chosen according to trailer configuration: select a heavy-duty cable return for aluminum caps and our Shur-Strap™ return for flat caps.

Key Features: 4-Spiral Torsion Springs per Arm, Shur-Strap™ w/Single-Arm Series, Heavy-Duty Aluminum Brackets, Heavy-Duty Aluminum Torsion Arms, Cab Wiring Kit for Standard Electric Hardware or Trailer Wiring Kit for SMARTwire™ Systems, Gate Flex™ w/Dual-Arm Kits, Exposed Spline w/Single-Arm Kits w/Shur-Strap™.

NOTE: 3" roll tube recommended for refuse and chip applications, for less deflection.



STANDARD FEATURES AND OPTIONS

RETURNS	
● 4-Spiral Torsion Springs per Arm	Standard
● Shur-Strap™ – Standard w/Single-Arm Kits	
Heavy-Duty Shur-Return™*	
Heavy-Duty Cable Return*	
Shock Cord Roll Return*	
MOUNTING BRACKETS	
● Heavy-Duty Aluminum Brackets	Standard
TORSION ARMS	
● Heavy-Duty Aluminum Arms	Standard
WIRING	
● Cab Wiring Kit (6 Ga.) – Standard w/30' Wire/Electric Hardware	
● Trailer Wiring Kit (6 Ga.) – Standard w/SMARTwire™	
Cab Wiring Kit (6 Ga.)** – Cab Wiring Only	Deduct
SPLINE CAPABILITY	
● Exposed Spline – For Kits w/Shur-Strap™	Standard
Manual Override Kit – For Kits w/Over 2" Hinge Depth	Add
ACCESSORIES	
Extra SMART3™ Remote	Add
SMARTwire™ 2-Light Kit w/o Remote - SMART3™	Add
SMARTwire™ 2-Light Kit w/o Remote - SMART2™	Add

*Returns should be chosen according to trailer configuration.

**Existing cab wiring kit MUST have been purchased from Shur-Co®. Deduction ex-cludes cab wiring kit ONLY.

STANDARD FEATURES AND OPTIONS

RETURNS	
● 4-Spiral Torsion Springs per Arm	Standard
● Shur-Strap™ – Standard w/Single-Arm Kits	
Heavy-Duty Shur-Return™*	
Heavy-Duty Cable Return*	
MOUNTING BRACKETS	
● Heavy-Duty Aluminum Brackets	Standard
TORSION ARMS	
● Heavy-Duty Aluminum Arms	Standard
WIRING	
● Cab Wiring Kit (6 Ga.) – Standard w/30' Wire/Electric Hardware	
● Trailer Wiring Kit (6 Ga.) – Standard w/SMARTwire™	
Cab Wiring Kit (6 Ga.)** – Cab Wiring Only	Deduct
SPLINE CAPABILITY	
● Gate Flex™ – Standard w/Double-Arm Kits	
● Exposed Spline – Standard w/Single-Arm Kits w/Shur-Strap™	
Manual Override Kit – For Kits w/Over 2" Hinge Depth	Add
ACCESSORIES	
Extra SMART3™ Remote	Add
SMARTwire™ 2-Light Kit w/o Remote - SMART3™	Add
SMARTwire™ 2-Light Kit w/o Remote - SMART2™	Add

*Returns should be chosen according to trailer configuration.

**Existing cab wiring kit MUST have been purchased from Shur-Co®. Deduction ex-cludes cab wiring kit ONLY.

In the chart at left, features that come standard are indicated, but you can also see what options are available for this application in each category.

4-SPIRAL TORSION SPRING



SHUR-STRAP™ RETURN



HEAVY-DUTY REAR CABLE RETURN

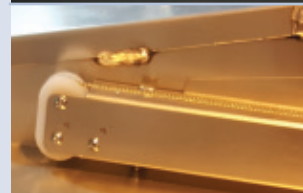

3-INCH ROLL TUBE



HEAVY-DUTY ALUMINUM ARMS



PATENTED SMARTWIRE™



GATE FLEX™



EXPOSED SPLINE



KEEPS CROPS DRY AND PROFITS HIGH



TATER-TOP™ FOR POTATO TRAILERS

“Loaded” with features, but without any hydraulics to weigh it down! Rolls and climbs to clear heaped potato loads – no bows needed. Hinged rear pivot arm swings all the way around the back to not obstruct rear doors and secures with locking brace. Fixed arm also available.

Tarp snugs up under the latchplate (a design originally patented on *The Original Shur-Lok®*) and a bungee in the tarp closes it tightly, with no overhang. A mini “Poor Boy” tail replaces the face panel. Powerful worm gear motor makes for improved clearance. 30-foot box limit.

Key Features: Worm Gear Motor, Universal Mounting Bracket, Heavy-Duty Steel Arms, Hinged Swing Pivot Arm w/Locking Rear Brace or Fixed Arm, Aluminum Latchplate, Mini “Poor Boy” Tail, SMART3™ Remote Compatible.

NOTE: If trailer is NOT already equipped with a Shur-Lok® tarp system, appropriate 3" roll tube Shur-Lok® kits available.



STANDARD FEATURES AND OPTIONS

MOTOR	
● Right-Angle Worm Gear Motor	Standard
RETURNS	
● 6-Spiral Torsion Spring per Arm	Standard
MOUNTING BRACKETS	
● HD Brackets Designed for Each Application	Standard
TORSION ARMS	
● Heavy-Duty Steel Arms	Standard
ACCESSORIES	
Extra SMART3™ Remote	Add
Extra SMART2™ Remote	Add
SMARTwire™ 2-Light Kit w/o Remote - SMART3™	Add

A Shur-Lok® Tater-Top system is required to operate properly with Electric Tater-Top™ kits (see below left). If an existing Shur-Lok® is installed, call to determine what can be reused. The Shur-Lok® Tater-Top™ kits in the following chart INCLUDE a solid vinyl-covered tarp in your choice of colors. The 3" larger tube size flexes less, for smoother operation.

SHUR-LOK® TATER-TOP KITS w/3" Roll Tube

	20'
	22'
	24'
	26'
	28'
	30'

STANDARD FEATURES AND OPTIONS

LATCHPLATE	
● Aluminum Latchplate	Standard
END CAPS	
● Aluminum Sloped Front End Cap	Standard
● Mini Poorboy Tail - For Tighter Fit Over Caps	Standard
Shur-Lok® Alum. Cap - 14" Deep Roof Panel	
TARP STOPS	
● Easy-Off Tarp Stops	Standard
BOWS/BRACKETS	
● Installation Kit* - 3 Bows/Brackets	Standard
TARP OPTIONS	
● 18-Oz. Vinyl Tarp - Choice of Colors	Standard
Multicolored Fabric (per added color)	Add
ACCESSORIES	
SMARTwire™ 2-Light Kit w/o Remote - S3	Add
Standard Tarp Repair Kit	Add
Professional Tarp Repair Kit	Add

*Supports tarp during installation process. Can also be used for display purposes or for hauling small grain.

In the chart at left, features that come standard are indicated, but you can also see what options are available for this application in each category.

SMART CAPABILITIES



WORM-GEAR MOTOR



HEAVY-DUTY STEEL ARMS



UNIVERSAL MOUNTING BRACKET



HINGED SWING PIVOT ARM



LOCKING REAR BRACE



ALUMINUM LATCHPLATE



MINI "POOR BOY" TAIL



MORE COMPACT SIZE, HIGHER CLEARANCE



AUTOTRAP™ ELECTRIC HOPPER OPENER

AutoTrap™ combines the best elements of Shur-Co® SMARTrailer™ design! You get a compact, high-clearance system at an affordable price, with patented SMARTwire™ connections and built-in compatibility with our SMART3™ and SMART2™ remotes.

The thru-bore motor design of the AutoTrap™ has performance characteristics comparable to our ProTrap® system but in a more compact size and weight – nearly 40 percent lighter! Its design also allows for easy one-bolt conversion to manual operation, if necessary. The protective polymer sleeve acts as an effective corrosion barrier between drive shaft and motor.

This system is “one-size-fits-all,” to interface with 1-inch, 7/8-inch or 3/4-inch crank shafts. Wireless operation via our pre-programmed SMART2™ remote is standard, and push-button controls at each opener are also included. Available in 1-hopper, 2-hopper, 3-hopper and 4-hopper stand-alone configurations or in combination with 4500 Series HD electric tarps.

Key Features: Thru-Bore Motor, Thru-Bore Drive Shaft w/3/4" Hex Milled End, Polymer Motor Sleeve, Universal Mounting Bracket, Hinge Bracket w/Shim Insulator, Integrated Rock Shield, Crank Shaft Adapter Kit, 1-Bolt Manual Changeover, Emergency Back-Up Crank, SMARTwire™ Sealed Harness, SMART2™ or SMART3™ Remote.





PROTRAP® ELECTRIC HOPPER OPENER

The best one-two punch in trailer automation! Pair your 4500 Series HD electric tarp with the ProTrap® electric hopper opener. It safely and smoothly slides hopper doors open and closed at the touch of a button while you stay back, safely out of the dust.

The ProTrap's all-metal gears and housing are designed to handle the hard stops, with a high-efficiency planetary gear reduction and a breaker circuit at the battery to protect the motor. It eliminates the need for unreliable limit switches that can be damaged going through fields.

Actual torque varies based on wire size, length and battery voltage; our motors are sized to best protect your trailer components. The 150 low-torque motor is standard for trailers with strap-style traps, the 250 motor for rack-and-pinion traps.

Our SMART2™ and SMART3™ remotes deactivate when the flip-style covers are closed or shut off after three minutes of inactivity. Everything is clearly labeled. The cab-mounted or trailer-mounted master disconnect switch kills power to the tarp and traps – no complicated button sequence required. Patented sealed, quick-connect SMARTwire™ harness reduces connector corrosion and adds plug-and-play convenience at install.

Key Features: All-Metal Gear Motor, Automatic Brake (Holds Door), Universal Mounting Bracket, Hinge Bracket w/Shim Insulator, 1-Bolt Manual Changeover, Master Disconnect Switch, SMARTwire™ Sealed Harness, SMART2™ or SMART3™ Remote.

NOTE: ProTrap® comes preassembled for faster install.



EASILY SWINGS YOUR AUGER INTO POSITION



DRIVEMAXX™ ELECTRIC AUGER DRIVE KIT

The final component to Shur-Co's complete "system solution" for remote operation at harvest time! Quickly swings your auger hopper into position from the comfort of the cab. Comes with its own LiteALL™ work light kit and plug-and-play SMARTwire™ connections.

Independent 2-wheel dual-motor drive is powered by 220 lb.ft. of torque per motor. Direct-drive motors are designed with right-angle rear drives and no chains or chain tensioners. Built rugged and dependable, with an aggressive tire tread. Sealed SMARTwire™ connections and receiver box, plus completely enclosed gear boxes, provide watertight reliability.

Included push-button LiteALL™ LED flood light kit in either a SMART2™ or SMART3™. An open light channel lets you add a second LiteALL™ to illuminate auger discharge or for placement on the main auger tube to light the work area.

Key Features: SMART Remote Compatibility, Independent 2-Wheel Dual-Motor Drive Kit, SMARTwire™ Connections, Sealed Receiver Box, Manual LiteALL™ LED Work Light Kit, SMART3™ Remote.





ELECTRIC GATE AND HOIST SYSTEM

Control box hoist and rear slide gates on farm bodies with our SMART2™ or SMART3™ remote. So versatile, it lets you add an electric tarp and traps, work lights – even a swing auger drive kit – and run it all with the same remote. It's fast, easy, and most of all, safe!

With the introduction of Shur-Co's SMART mini-modules, you have the ability to control any 12-volt accessory on your truck or trailer. The combination of the mini-module and an electric actuator gives you full control over the rear slide gate. A second mini-module with our electric-over-air solenoid valve gives you control of your hoist. No more climbing up and down bins to adjust flow from the truck into your auger.

All wiring connections utilize environmentally sealed WeatherPack™ connectors on the hoist controls and D.O.T.-certified air fittings. If ordered with an electric tarp, includes patented SMARTwire™ package for easy install.

Key Features: SMART2™ or SMART3™ Remote, 12-Volt Electric Shur-Co® Motor, Sealed Receiver Box, SMARTwire™ Mounting Brackets, D.O.T.-Certified Air Fittings.



GATES ARE OPENED AND SHUT FOR YOU



AUTOGATE™ GATE RUNNER

No need to get out of your tractor or truck when going through gates – this does the work for you, safely and easily. Use your SMART3™ remote to fully open and close gates up to 18 feet wide with one quick press of a button – opens or shuts completely in 10 to 15 seconds.

Safety feature provides automatic shut-off if gate is obstructed. Installation is easy, and solar panel is included for convenient battery charging. Travel limits up to 100 degrees are configurable via Shur-Co's SMART3™ app.*

*Android phones ONLY.

Key Features: Linear Actuator, SMART Remote Compatibility, Maintenance-Free 12V Battery, Control Box, Solar Panel, Complete Mounting Bracketry.

ALSO - Power Your Tarp Without Wiring Your Truck!

Harness the power of the sun for your electrics! Solar pack converts the sun's energy into battery-charging power. It's rated for over 5,000 cycles. Installs vertically or horizontally.

Key Features: 30-Watt Solar Panel, Sealed 12-Volt Gel Cell Battery, Aluminum Battery Box, Mounting Hardware.





ELECTRIC TURNING POINT™ BOW SYSTEM

Bows move as one, swinging up and out of the way for wide-open loading. The operator can remain safely in the cab while operating the system with a rocker switch or our SMART2™ or SMART3™ remote. The center pivoting ridgepole holds the tarp without sagging.

With the Electric Turning Point™ Bow system, you need fewer bows – and those you do need open simultaneously for easier loading. Our exclusive locking system provides secure support during transport and serves as a skid plate when the bows swing closed.

The electronic actuator is designed for longer life in the harshest outdoor conditions, operating safely in temperatures ranging from -86 to 140 degrees Fahrenheit. Integrated brakes lock out movement, a slip clutch automatically protects the actuator from overload and a cut-off switch prevents operation unless the roll tarp is completely open.

NOTE: When using SMART remotes, there is no positional feedback and Express Mode is not available. However, it will work with other SMART applications.

Key Features: Electric Cut-Off Switch, Automatic Overload Slip Clutch, Locking Skid Plate, Bow Actuator, Actuator Brakes, Easy Electric-to-Manual Conversion.



OPENS MANUAL TRAPS QUICKLY AND EASY



TRAPADAPT™ MANUAL TRAP OPERATOR

Does the work of an electric hopper opener for you, saving time and helping elevator staff be more efficient. Time equals money, and this aluminum-handled kit speeds things up. Handle has a forward-and-reverse switch built right in and weighs just 21 pounds for easy lifting.

Main socket is designed to fit most popular-brand hoppers on the market. Durabuilt™ worm-gear motor has a 90:1 gear ratio and 3/4-inch motor shaft. Vented aluminum battery box is equipped with an on/off switch, motor-reversing solenoid, 8-amp charger, manual override breaker and battery* hold-down.

Handle, motor and battery box all come attached to an included 2-wheel cart and weigh less than 70 pounds without a battery. Also available is an optional 5-inch LED light.

Key Features: Aluminum Handle w/Forward-and-Reverse Switch, Worm Gear Durabuilt™ Motor, Vented Aluminum Battery Box w/On and Off Switch, 2-Wheel Cart.

*Battery is NOT furnished; Group 27 or 31 Deep-Cycle Marine Battery recommended for best results.



LITEALL™ LED WORK LIGHT PACKAGES

It's the perfect combination of affordability, durability and functionality! Complete 12-volt system is designed to use with our SMART2™ and SMART3™ remotes, letting you work into the night when you need to with high-intensity flood beams on adjustable hinged brackets.

LiteALL's work lights are set into hinged mounting brackets that swivel forward and back, and an available 20-foot extension cable provides even more adaptability. Features built-in flexibility for manual operation using trailer-mounted control module. Specifications: IP67 waterproof rating, 1600 lumens, 24-watt output, 1.8-amp draw and 30,000 hours estimated life.

LiteALL™ features SMART compatibility with the SMART2™ – with digital feedback – or the 5-channel SMART3™ remote. Deactivates when lid is closed or after 3 minutes of inactivity. Control modules include 2 output channels with WeatherPack™ connectors. Select a complete 2-light kit or individual components to fit your needs (see next page).

Key Features: Swivel-Bracket Lights, Control Module, Complete Mounting Hardware.

NOTE: Does NOT include SMART Remote, Extension Cable or SMARTwire™ Adapter.



COMPONENTS FOR LEGACY SMART1+™ SYSTEMS

Available for a limited time. Control modules fit Legacy systems to allow continued operation.

P/N 1121563 – SMART1+™ Control Module w/ Legacy Trailer Connectors

P/N 1125725 – SMART1+™ Control Module w/ WeatherPack Connectors





P/N 1122108 – SMART2™ Remote

Controls SMART2™ LiteALL™ and 12V electric accessories, with digital feedback. Deactivates when cover is closed or after 3 minutes of inactivity. Includes remote, cradle (P/N 1704955) and charging cable (P/N 1704958).

P/N 1127810 – SMART2™ Control Module* (see on pg. 23)

Includes 2 output channels with WeatherPack™ connectors. Provides on/off status to SMART2™ remote. WeatherPack™ connector on 8-foot cable must be wired to 12V DC. Utilize SMARTwire™ adapter (P/N 1122690) to connect 8-foot power cable to patented SMARTwire™ plug-and-play connections. Voltage: 10-16V DC. Current: 8A max per output.

*Also available with output adapter cables with 2-way molded bullet connectors for plug-and-play connection to Legacy LiteALL™ kit (P/N 1127809).

P/N 1126867 – SMART3™ Remote

Controls SMART3™ LiteALL™ and additional SMARTrailer™ accessories. Deactivates when lid is closed or after 3 minutes of inactivity. Uses two AAA batteries.

P/N 1127598 – SMART3™ Control Module** (see on pg. 23)

Control module has 2 output channels. Both output cables and 8-foot power cord have WeatherPack™ connectors. Utilize SMARTwire™ adapter (P/N 1122690) to connect power cable to patented SMARTwire™ plug-and-play connectors. Voltage: 10-16V DC. Current: 8A max per output.

**Also available with output adapter cables with 2-way molded bullet connectors for plug-and-play connection to Legacy LiteALL™ kit (P/N 1127597).



P/N 1120849 - Junction Block Kit w/Harness Plug

Connects to 12V power on pre-existing systems installed on 4500 HD/ProTrap® combos. Unplug SMARTwire™ dual-conductor socket from 4500 receiver box, insert SMART-wire™ junction block. LiteALL™ will then draw power from block using SMARTwire™ adapter wire (P/N 1122690).

P/N 1119520 - Junction Box

Connects to 12V power on existing 3500s, non-SMARTwire™ 4500s or other non-SMARTwire™ systems (already installed on most 3500/ProTrap® combos). Includes 3-foot 6-ga. wire and 6-ga. x 1/4-inch ring terminals (4) into a 3-light system (splitter lets you add an additional light).



P/N 1122706 – LiteALL™ LED Work Light***

High-intensity LED flood beam in hinged bracket, 13-foot power cord with WeatherPack™ connectors. Output: 1600 lumens. Power: 24 watts. Estimated life: 30,000 hours.

*** Also available w/molded 2-way bullet connector (P/N 1704719).

P/N 1120672 – Mounting Hardware Kit

Includes rubber grommet insert and rubber grommet, plus nylon wire clips (6) and self-drilling screws (6).



P/N 1126433 – 10-Ft. Cable w/WeatherPack™ Connectors

Provides additional flexibility in mounting location of control module. Also available in 20-foot length (P/N 1122742).

P/N 1122704 – 20-Ft. Cable for Output to LED Light****

WeatherPack™ connectors, 2-way conductor, 18-ga. cable for additional positional flexibility and easy install of wiring.

**** Also available w/molded 2-way bullet connectors (P/N 1704740).



P/N 1120670 – SMARTwire™ Dual-Conductor Socket

Trailer socket connection for 12V power if none previously exists. Opposite end of 3-foot conductor socket wire is plug-and-play compatible with SMARTwire™ junction blocks.

P/N 1122705 – LiteALL™ Output Splitter*****

Powers 2 lights from 1 channel. WeatherPack™ connectors form a sealed connection. Each splitter lets you add a light.

***** Also available w/molded 2-way bullet connectors (P/N 1704773).



P/N 1127599 – Output Adapter Cable

Lets WeatherPack™ connectors on module output connect to Legacy LiteALL™ with molded 2-way bullet connectors.

P/N 1122690 – SMARTwire™ Adapter*****

Easy install into SMARTwire™ systems. WeatherPack™ connectors eliminate splicing into existing truck/trailer wiring.

***** Also available w/Legacy round 2-way connector (P/N 1121568).

KEY FEATURES

1. SILICONE SEALS

SMARTwire™ plugs and sockets utilize automotive-grade silicone seals to prevent water intrusion. Capable of temporary immersion, these connectors can survive harsh environments including off-road applications and exposure to road salt and de-icing chemicals.

3. BRASS PINS AND SOCKETS

The pins and sockets in our SMARTwire™ high-current connectors are CNC machined to close tolerances, guaranteeing a tight, low-resistance connection every time. These connectors have the same resistance as the 6-gauge cable, so you won't see additional voltage loss.

2. MOLDED PLUGS

Shur-Co® high-current plugs and sockets are over-molded directly onto the 4- or 6-gauge cable. This produces a waterproof seal at the back of the plug, preventing water intrusion along the cable.

4. WIRES AND CABLES

Shur-Co® wire and cable materials were selected for high flexibility, chemical resistance and wide temperature range. We use high-strand count copper conductors in our 4- and 6-gauge cables, allowing easier routing and tight radius bends.

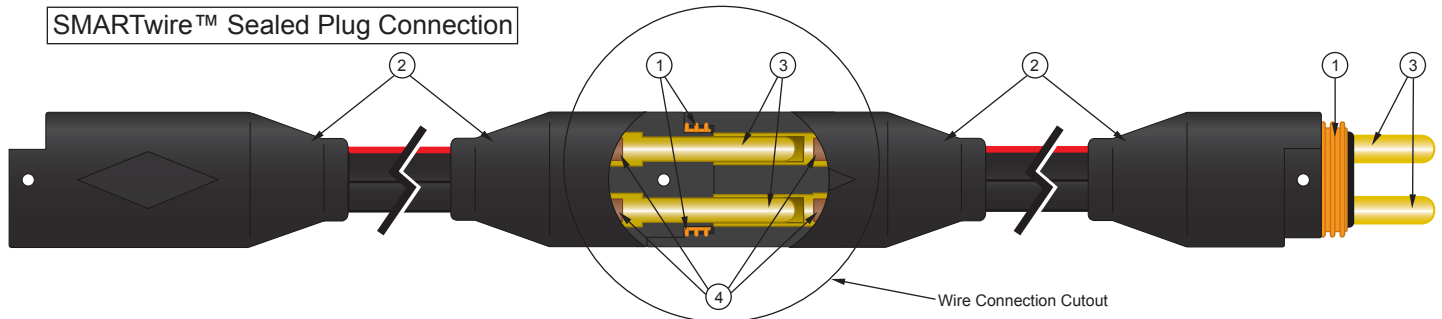

LOCKING PINS

SMARTwire™ high-current connectors have through holes to accept stainless locking pins. The locking pins prevent connector separation which can occur under high-shock loads or when the cables get covered with mud or ice.



EASY INSTALLATION AND EXPANSION

SMARTwire™ cables come fully terminated – no more stripping and crimping. You select the length, wire gauge and connectors or terminations to fit your application. When you need to connect to more than one device, our fully sealed 3-way Harness Junction Block converts one input to 3 outputs. It utilizes our precision-machined, low-resistance pins and sockets and our stainless locking pins.



WIRE SPECIFICATIONS AND SUGGESTED APPLICATIONS

SMARTWIRE™ SPECIFICATIONS

Voltage Rating	38 volts DC max
Current Rating	100 amps continuous, 200 amps peak (for no more than 10 seconds)
Connector Style	Over-molded 2-conductor with silicone gasket seal and locking pin
Contact Style	Precision-turned brass pins and sockets
Connector Sealing	Immersion tested to 12" water depth
Wire Gauges Available	4AWG and 6AWG
3-Way Junction Block Available	Splitter module available to supply power to multiple accessories
Patents	Active and pending patents can be found at www.shurco.com/patents

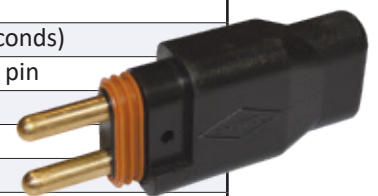

SUGGESTED APPLICATIONS

Truck and Trailer Accessories	Wire all your accessories including spot lights, winches, EMS light bars and more while keeping your electric connections protected.
Marine Accessories	Operate all your accessories, including trolling motors, lights, fish finders, boat lifts and more while ensuring the connectors remain dry and secure.
Charging Vehicles and Scooters	Keep moving and feel confident your mode of transportation will be properly charged* when you need it.
Snow Plow Lighting and Actuators	Have the peace of mind that your snow removal equipment will have power when you need it in the harshest environments.
ATV Winch Power	Keep your ATV winch and other electric accessories ready for work or recreation.

*Use of a properly operating and maintained charger must be used. Shur-Co® is not responsible for undercharging due to the charger not working or not maintained properly. Your battery charger must be properly rated for your application

SAMPLE WIRING CONFIGURATIONS

MARINE ACCESSORIES*

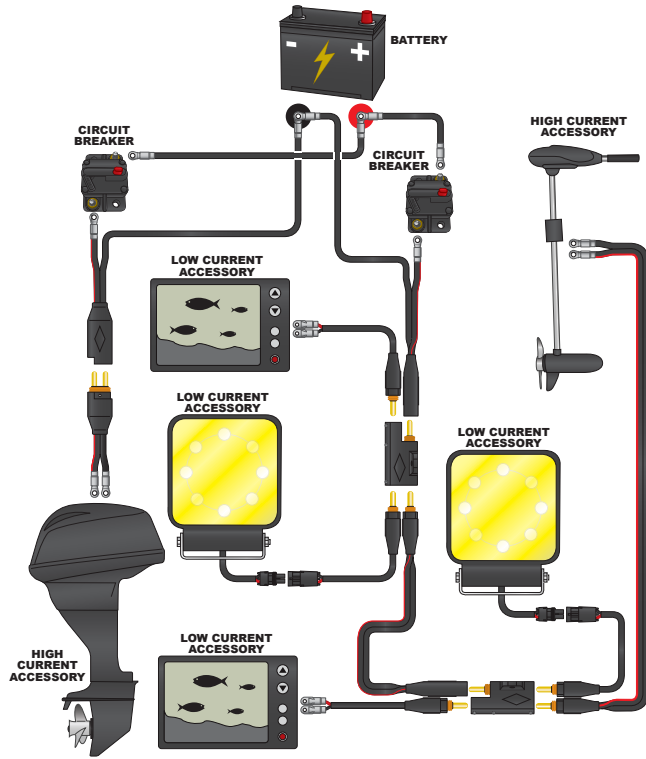

TRUCK ACCESSORIES*

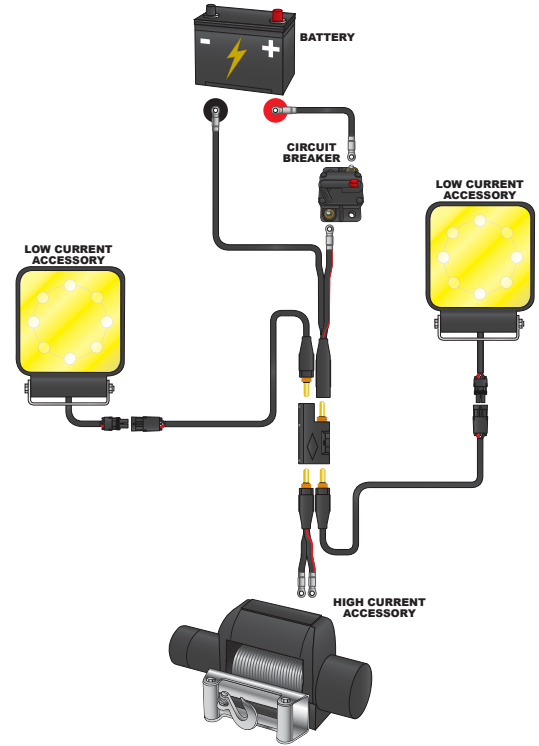

SALT SPREADER ACCESSORIES*

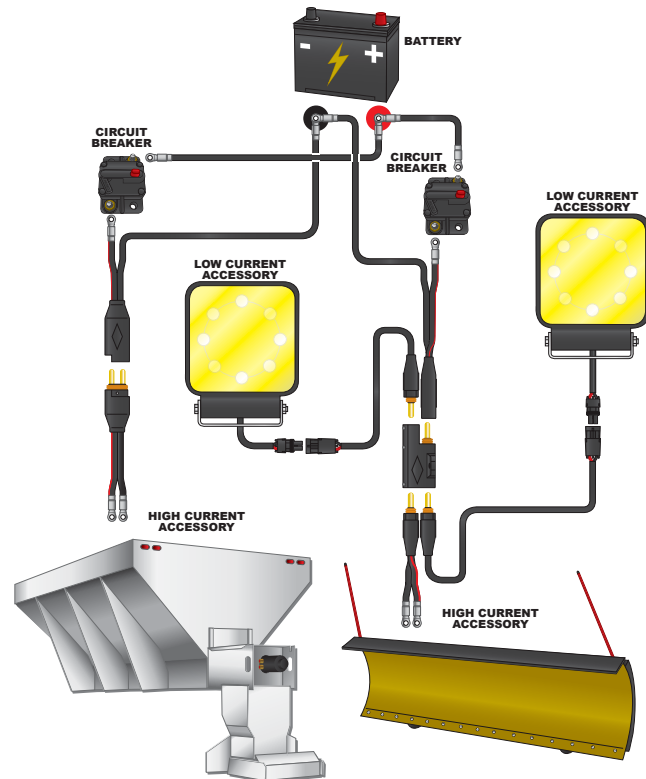

TRUCK AND TRAILER ACCESSORIES*

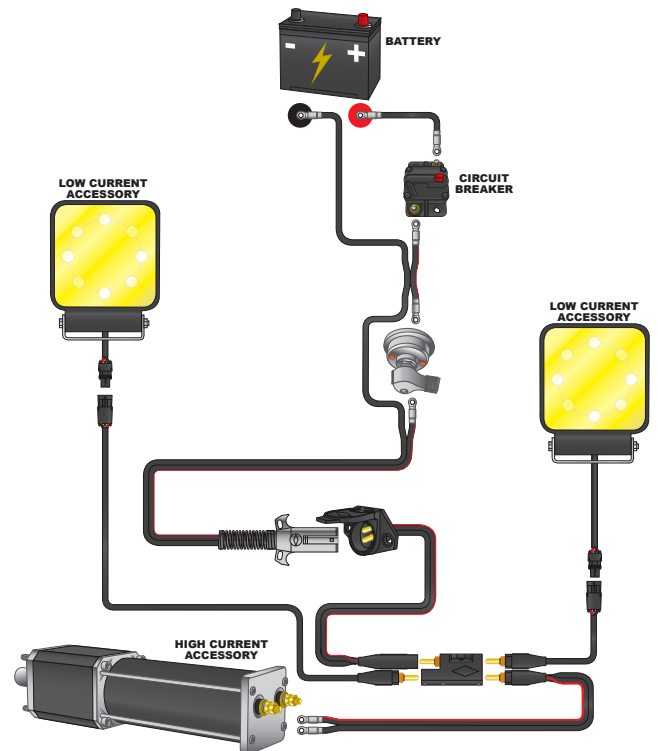

*The sample wiring configurations are for illustration purposes only. Contact the manufacturer of your accessories for specific wiring requirements.

ORDERING INSTRUCTIONS

BUILDING YOUR CUSTOM SMARTwire™ PART NUMBER

Wire Termination #1



ITEM NO.
02

Wire Type & Length

10'4"

4- or 6-Gauge SMARTwire™

ITEM NO. WIRE LENGTH*

02 - 1004

FEET INCHES

Wire Termination #2



ITEM NO.
01

WIRE TERMINATION OPTIONS

CONNECTORS		
ITEM	DESCRIPTION	PAGE
01	SMARTwire™ Male	8
02	SMARTwire™ Female	8
03	2-Pole Socket	8
04	2-Pole Plug	8
RING TERMINALS		
ITEM	DESCRIPTION	PAGE
05	#10 Ring w/Heat Shrink	9
06	1/4" Ring w/Heat Shrink	9
07	5/16" Ring w/Heat Shrink	9
08	3/8" Ring w/Heat Shrink	9
09	1/2" Ring w/Heat Shrink	9
BLUNT		
ITEM	DESCRIPTION	PAGE
10	Blunt Wire	9
11	Stripped and Split Wire	9

WIRE TYPE OPTIONS

HIGH CURRENT		
ITEM	DESCRIPTION	PAGE
01	4-Gauge SMARTwire™	10
02	6-Gauge SMARTwire™	10

WIRE TERMINATION OPTIONS

CONNECTORS		
ITEM	DESCRIPTION	PAGE
01	SMARTwire™ Male	8
02	SMARTwire™ Female	8
03	2-Pole Socket	8
04	2-Pole Plug	8
RING TERMINALS		
ITEM	DESCRIPTION	PAGE
05	#10 Ring w/Heat Shrink	9
06	1/4" Ring w/Heat Shrink	9
07	5/16" Ring w/Heat Shrink	9
08	3/8" Ring w/Heat Shrink	9
09	1/2" Ring w/Heat Shrink	9
BLUNT		
ITEM	DESCRIPTION	PAGE
10	Blunt Wire	9
11	Stripped and Split Wire	9

*Wire length does not include the added length of wire termination connectors and/or ring terminals.

ITEM NO. **SMARTwire™ Dual Male**

01

Voltage Rating	38 volts DC max
Current Rating	100 amps continuous, 200 amps peak (for no more than 10 seconds)
Connector Style	Over-molded 2-conductor with silicone gasket seal and locking pin
Contact Style	Precision-turned brass pins and sockets
Connector Sealing	Immersion tested to 12" water depth
Measurements	H: 1.375"; L: 3.512"; W: .813"
Mates With	SMARTwire™ Dual Female & SMARTwire™ Junction Block



NOT TO SCALE.

ITEM NO. **SMARTwire™ Dual Female**

02

Voltage Rating	38 volts DC max
Current Rating	100 amps continuous, 200 amps peak (for no more than 10 seconds)
Connector Style	Over-molded 2-conductor with silicone gasket seal and locking pin
Contact Style	Precision-turned brass pins and sockets
Connector Sealing	Immersion tested to 12" water depth
Measurements	H: 1.375"; L: 3.453"; W: .813"
Mates With	SMARTwire™ Dual Male & SMARTwire™ Junction Block



NOT TO SCALE.

ITEM NO. **2-Pole Vertical Socket**

03

Voltage Rating	38 volts DC max
Current Rating	100 amps continuous, 200 amps peak (for no more than 10 seconds)
Connector Style	Vertical pins
Contact Style	Precision-turned brass
Mates With	2-Pole Vertical Plug



NOT TO SCALE.

ITEM NO. **2-Pole Vertical Plug**

04

Voltage Rating	38 volts DC max
Current Rating	100 amps continuous, 200 amps peak (for no more than 10 seconds)
Connector Style	Vertical pins
Contact Style	Precision-turned brass
Mates With	2-Pole Vertical Socket



NOT TO SCALE.

ITEM NO. **#10 Ring Terminal w/Heat Shrink**

05



NOT TO SCALE.

ITEM NO. **1/4" Ring Terminal w/Heat Shrink**

06



NOT TO SCALE.

ITEM NO. **5/16" Ring Terminal w/Heat Shrink**

07



NOT TO SCALE.

ITEM NO. **3/8" Ring Terminal w/Heat Shrink**

08



NOT TO SCALE.

ITEM NO. **1/2" Ring Terminal w/Heat Shrink**

09



NOT TO SCALE.

ITEM NO. **Blunt Wire**

10

Strip Length	0.00"
Slit Length	0.00"



NOT TO SCALE.

ITEM NO. **Stripped and Split Wire**

11

Strip Length	0.50"
Slit Length	1.75"



NOT TO SCALE.

ITEM NO. **4-Gauge SMARTwire™**

01

Voltage Rating	38 volts DC max
Current Rating	130 amps continuous, 200 amps peak (for no more than 10 seconds)
Insulation Colors	Black/red
Conductor	Multi-stranded
Length	Up to 30' in 5' increments, up to 100' in 10' increments*

*Minimum quantities may be required.

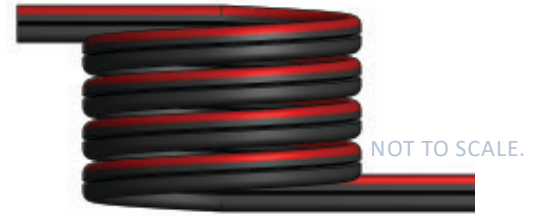

ITEM NO. **6-Gauge SMARTwire™**

02

Voltage Rating	38 volts DC max
Current Rating	100 amps continuous, 200 amps peak (for no more than 10 seconds)
Insulation Colors	Black/red
Conductor	Multi-stranded
Length	Up to 30' in 5' increments, up to 100' in 10' increments*

*Minimum quantities may be required.



ITEM NO. **Harness Junction Block/Splitter Kit**

01

Voltage Rating	38 volts DC max
Current Rating	100 amps continuous, 200 amps peak (for no more than 10 seconds)
Connector Style	Over-molded 2-conductor with silicone gasket seal and locking pin. Includes one "power in" connector and 3 "power out" connectors.
Contact Style	Precision-turned brass pins and sockets
Connector Sealing	Immersion tested to 12" water depth
Measurements	H: 2.988"; L: 3.531"; W: 1.813"
Mates With	SMARTwire™ Dual Male & SMARTwire™ Dual Female
Includes	1-Harness Junction Block/Splitter (1704695), 1-Wire Harness Rubber Plug (1704717), 2-Harness Lock Pin - Long (1704696), 1-Harness Lock Pin - Short (1704711) and 2-Self-Tapping Screw (1704388)
Shur-Co® P/N	1120849



ITEM NO. **Wire Harness Rubber Plug**

02

Mates With	SMARTwire™ Junction Block/Splitter*
Shur-Co® P/N	1704717

*Fills unused ports on Harness Junction Block/Splitter.



ITEM NO. **Harness Lock Pin - Long**

03

Works With	SMARTwire™ Junction Block/Splitter
Shur-Co® P/N	1704696



ITEM NO. **Harness Lock Pin - Short**

04

Works With	SMARTwire™ Junction Block/Splitter
Shur-Co® P/N	1704711



ITEM NO. **Harness Lock Pin - Blunt**

04

Works With	SMARTwire™ Male & SMARTwire™ Female
Shur-Co® P/N	1704751

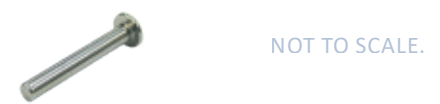

ITEM NO. **Master Disconnect Rotary Switch**

06

Voltage Rating	38 volt
Current Rating	100 amps continuous
Termination Type	3/8" stud
Shur-Co® P/N	1704283



ITEM NO.

07

40 AMP Modified-Reset Circuit Breaker

Voltage Rating	12 volt
Current Rating	40 amp
Reset Method	Type II - modified
Termination	#10-32 thread
Shur-Co® P/N	1704354

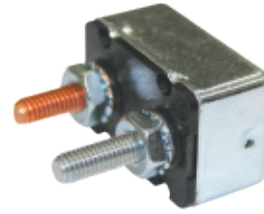

NOT TO SCALE.

ITEM NO.

08

SMARTwire™ to Weather Pack* Assembly

Voltage Rating	12-36 volt
Current Rating	20 amp
Wire Gauge	14 gauge
Termination	SMARTwire™ Dual Male & Weather Pack Plug
Length	Approx. 12"
Shur-Co® P/N	1122690

**Shur-Co, LLC is not related to or affiliated with J.R. Greenleaf & Company or White Products Division.*



NOT TO SCALE.

ITEM NO.

09

SMARTwire™ to Blunt End Wire Assembly

Voltage Rating	12-36 volt
Current Rating	20 amp
Wire Gauge	14 gauge
Termination	SMARTwire™ Dual Male & Blunt End
Length	Approx. 12"
Shur-Co® P/N	1704758



NOT TO SCALE.

ITEM NO.

10

Rubber Grommet - Narrow

Dimensions	D: 1.125"; W: .344"
Skin Thickness	.094"
Shur-Co® P/N	1704721

**Compatible with 6-gauge SMARTwire™.*



NOT TO SCALE.

ITEM NO.

11

Rubber Grommet - Thick

Dimensions	D: 1.125"; W: .625"
Skin Thickness	.250"
Shur-Co® P/N	1704722

**Compatible with 6-gauge SMARTwire™.*



NOT TO SCALE.

**More connection options may be possible. Please call to inquire.*

CONTACT INFORMATION

NAME _____

BUSINESS _____

ADDRESS _____ CITY _____ STATE _____ ZIP _____

EMAIL _____ PHONE (_____) _____ FAX (_____) _____

DESCRIBE YOUR INTENDED USE

ORDER DETAILS

WIRE ORDER EXAMPLE

CUSTOM SMARTwire™ PART NUMBER: 02 - 02 - 1004 - 01
 QUANTITY: 10

WIRE ORDER #1

CUSTOM SMARTwire™ PART NUMBER: _____ - _____ - _____ - _____
 QUANTITY: _____

WIRE ORDER #2

CUSTOM SMARTwire™ PART NUMBER: _____ - _____ - _____ - _____
 QUANTITY: _____

WIRE ORDER #3

CUSTOM SMARTwire™ PART NUMBER: _____ - _____ - _____ - _____
 QUANTITY: _____

WIRE ORDER #4

CUSTOM SMARTwire™ PART NUMBER: _____ - _____ - _____ - _____
 QUANTITY: _____

WIRE ORDER #5

CUSTOM SMARTwire™ PART NUMBER: _____ - _____ - _____ - _____
 QUANTITY: _____

Fax 605-665-0501 Salesperson _____

ORDER FORM

Customer ID# _____
 PO# _____ Date _____ Source Code _____
 Name _____
 Address _____ Email _____ Phone _____
 City _____ State _____ Zip _____
 END USER Ship To _____
 DEALER Credit Card Information _____
 EXTRA TRANSMITTERS* _____ Exp. Date _____
 *Normally comes with one but can program up to five. Code _____

WHICH OF THESE SYSTEMS DO YOU CURRENTLY OWN?

EXISTING 3500 SERIES EXISTING 4500 SERIES
 Rocker SMARTtransmitter® SMART1 +™ SMART3™
 SMART2™ Vers. 8 Vers. 9 Other _____
 Does it have SMARTwire™? Yes No

EXISTING PROTRAP® SMARTtransmitter®
 SMART1 +™ SMART3™
 SMART2™ Vers. 8 Vers. 9 Other _____
 Does it have SMARTwire™? Yes No

LIKE TO ADD?

4500 SERIES HD
 PROTRAP®/AUTOTRAP™
 PROTRAP®/4500 HD COMBO
 AUTOTRAP™/4500 HD COMBO

4500 Series Grain Trailer

TRAILER MAKE

Wilson Cornhusker
 Timpte Neville*
 Western* Merritt*
 Dakota Wheeler*
 Jet Co.* Hart Mfg.
 Maurer Stoughton
 Other _____
 Year _____
 *Backer plate recommended for these brands.

FRONT OF TRAILER
 Vertical Sloped

ROLL DIRECTION OF TARP
 Standard Reverse Roll

REAR DOOR STYLE
 Standard Top Hinge Side Hinge
 Depth: Ladder _____ Catwalk _____

LADDER POSITION
 Driver Side Passenger Side
 Center Off-Center Driver/Pass.
 Rib/Rivet Spacing _____

ELECTRIC CONTROLS OPTION
 Rocker Switch*
 *For 4500 alone, no ProTrap®/AutoTrap™ combos.
 WIRELESS - SMART2™
 WIRELESS - SMART3™

The following MUST be ordered separately.
CRANK RETAINERS - Qty 2
 (Used to store the crank under the king pin.)
 Yes No

U-CLAMPS & SCREWS
 Existing Shur-Loks® will need new U-clamps/
 screws to reattach the tarp to the roll tube.
 U-Clamps Screws

AutoTrap™/ProTrap®

TRAILER MAKE

Wilson Timpte* Jet Co.
 Dakota* Cornhusker Maurer
 Merritt Stoughton Neville
 Other _____ Year _____
 *For these brands, special bracketry may be required.

Currently have a 3500/4500 with rocker switch?
 Want to convert to Wireless? Yes No

MOTOR INSTALL LOCATION *Utilizes U.S. Driver Side controls.
 U.S. Driver U.S. Curb Side*

STYLE Rack & Pinion Strap-Trap

SHAFT DIAMETER
 1" 7/8" 3/4" Other

KNOCK RAIL Yes No

FRONT HOPPER
 Direct Drive - Clockwise**
 Direct Drive - Counterclockwise**

BACK HOPPER
 Direct Drive - Clockwise**
 Direct Drive - Counterclockwise**
 **Direction is from the view of where motor will be mounted.

Train Electric Systems Available in Wireless ONLY.

NOTE: MUST go through special quote and SOP to get pricing, plus lead wire kit and coiled wire plug will be added to price.

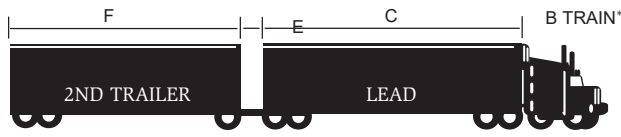
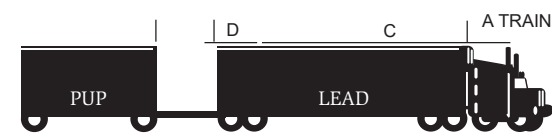

**Second trailer can be pulled independently by a tractor.

Shaft Diameter _____ **D** _____ Tongue Length on Pup (A TRAIN) SOLAR Yes No
 LEAD/PUP TRAINS (Refer to above illustration.) **E** _____ Distance Between Lead and Trailer (B TRAIN) Pull/Pup Yes No
C _____ Lead Train Length **F** _____ Pull/Pup Train Length Lead Yes No

ORDER FORM

Customer ID# _____

PO# _____ Date _____ Source Code _____

Name _____

Address _____ Email _____ Phone _____

City _____ State _____ Zip _____

END USER Ship To _____

DEALER

EXTRA TRANSMITTERS* _____

Credit Card Information _____



Exp. Date _____

Code _____

*Normally comes with one but can program up to five.

4500 Series End Dump

EQUIPPED WITH GATE FLEX™ OPTION TO ACCOMMODATE END DUMP DOORS

Make _____

Year _____

FRONT OF TRAILER

Vertical Sloped

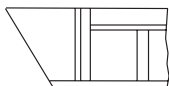
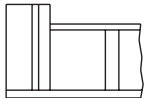

REAR DOOR STYLE

Top Hinge*

*Must be level with or below the top rail.

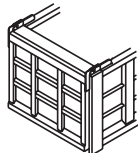

REAR HINGE DEPTH

0"-10"

11"-17"

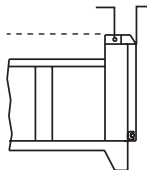

MANUAL OVERRIDE KIT**

Yes No

**Recommended for hinge depth greater than 2".

QTY OF ELECTRICAL WIRE

75' 100'

SWITCH OPTION

Rocker Switch Wireless

REMOTE OPTION

SMART2™ SMART3™

ADDITIONAL ITEMS TO ASK ABOUT

Are existing roll tubes in good shape?

Need easy-off 6" offset tarp stops?

Replacement U-clamps and screws?

Will fit these trailer styles:

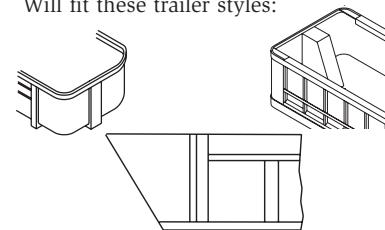

These styles will need modification in order to operate properly:

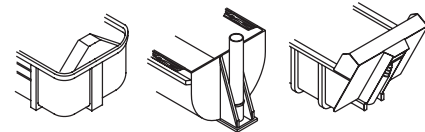

4500 Series Live Bottom

Make _____

Year _____

FRONT OF TRAILER

Vertical Sloped

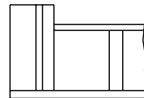

REAR DOOR STYLE

Top Hinge* Side Hinge

REAR HINGE DEPTH

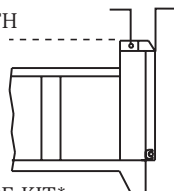

MANUAL OVERRIDE KIT*

Yes No

*Recommended if hinge depth is greater than 2".

RIB SPACING

Front _____ Rear _____ **

**Measure from center of rib to center of rib.

CATWALK DEPTH _____

LOCATION OF LADDER

Driver Side Pass. Side Center

TRAILER MODEL

2006 or Newer Older

BACK CAP CHOICE***

Aluminum Fabric Cap

***Must be 20-1/4" deep.

SWITCH OPTION

Rocker Switch Wireless

REMOTE OPTION

SMART2™ SMART3™

ADDITIONAL ITEMS TO ASK ABOUT

Are existing roll tubes in good shape?

Need easy-off 6" offset tarp stops****?

Replacement U-clamps and screws?

****Required for Top Hinge Rear Door Kits.

KNIFE GATE

Yes No

ANGLE

45° 57°

BELT WIDTH

36" 42" 48" 60"

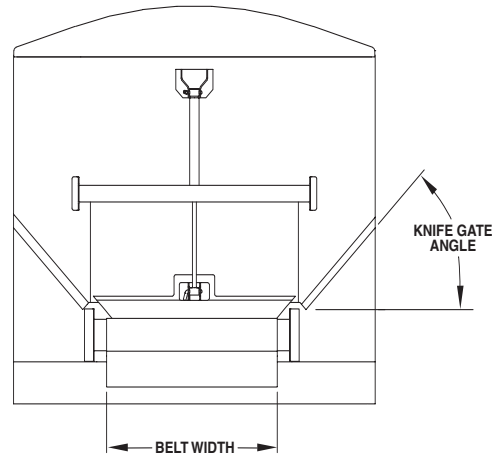

GRAIN CART & GRAVITY WAGON ORDER FORM

CORRECT PHYSICAL MEASUREMENTS ARE ESSENTIAL FOR PROPER TARP FIT. PROVIDE ALL REQUESTED INFORMATION OR YOUR ORDER MAY BE DELAYED. **DO NOT** USE UNIVERSAL BOX SIZES. **ALWAYS** USE ACTUAL MEASUREMENTS. BOX SIZE AND FINISHED TARP SIZE ARE NOT THE SAME.

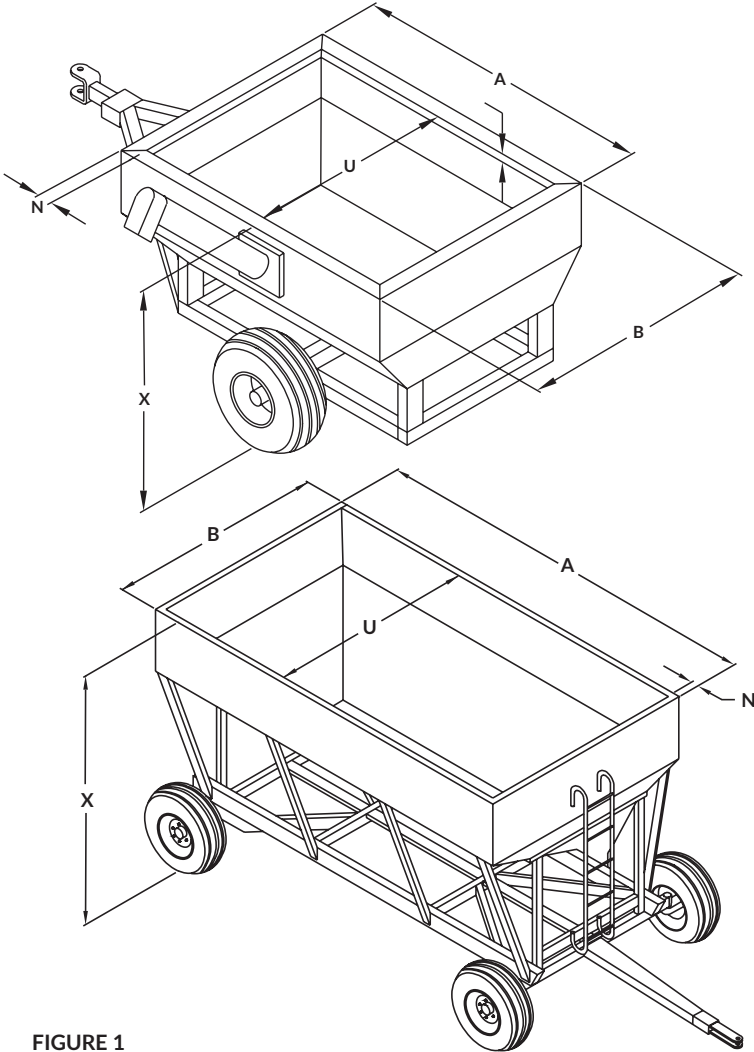

FIGURE 1

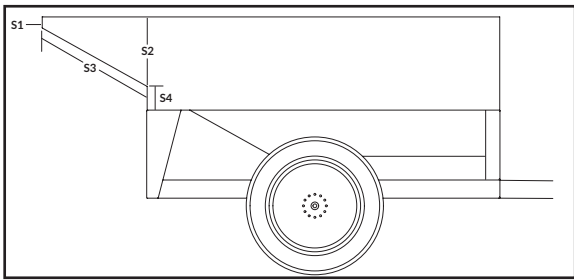
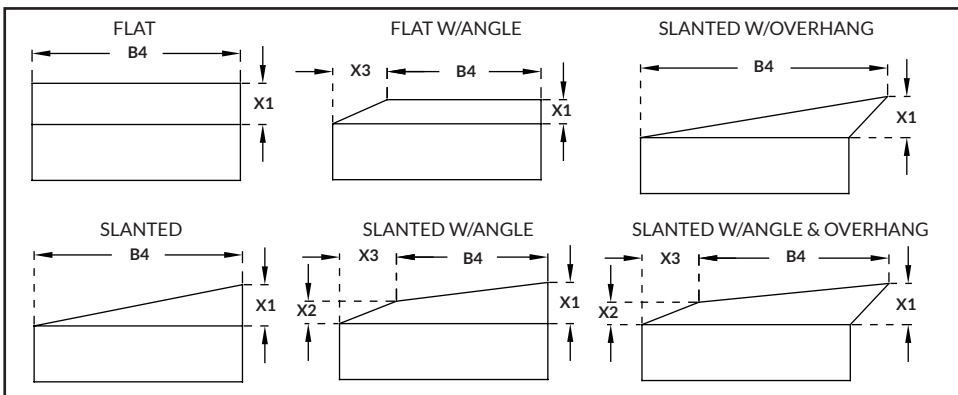

FIGURE 2



NOTE: Flat caps can ONLY be used on a SLANTED extension (see above), and the side walls MUST BE VERTICAL.

CONTACT INFORMATION

G01BD-0618

NAME _____
 ADDRESS _____
 EMAIL _____
 CITY _____ STATE _____ ZIP _____
 PHONE _____ FAX _____
 BOX/TRAILER MAKE _____
 MODEL _____ YEAR _____

BOX DIMENSIONS

A _____ UPPER OUTSIDE BOX LENGTH
 B _____ UPPER OUTSIDE BOX WIDTH
 Front _____ Center _____ Rear _____
 N _____ TOP RAIL WIDTH
 U _____ INSIDE BOX WIDTH
 X _____ UPPER OUTSIDE BOX HEIGHT

LIP IN LIP OUT

REAR CONFIGURATION *Must answer this*

VERTICAL SLOPED

REAR SLOPE DIMENSIONS *See Figure 1*

S1 _____ REAR UPPER VERTICAL
 S2 _____ SLOPE HEIGHT
 S3 _____ SLOPE LENGTH
 S4 _____ REAR CROSSBEAM HEIGHT

BOX EXTENSION STYLE *See Figures 2 and 3*

FLAT SLANTED FLAT W/ANGLE
 SLANTED W/ANGLE SLANTED W/OVERHANG
 SLANTED W/OVERHANG AND ANGLE

BOX EXTENSION DIMENSIONS

B4 _____ EXTENSION WIDTH
 X1 _____ EXTENSION HEIGHT DRIVER SIDE
 X2 _____ EXTENSION HEIGHT PASSENGER SIDE
 X3 _____ LOWER EXTENSION ANGLE

TARP COLOR(S) _____

FIGURE 3

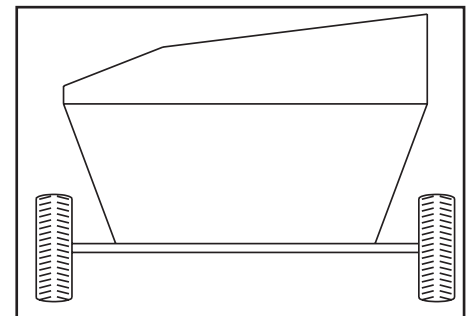

NOTE: If ordering galvanized caps, make sure box is flat across top. Figure 2 shows a box with an uneven angle across the top. Galvanized caps will NOT fit this box; you must order fabric caps instead.

DRIVEMAXX™ ORDER FORM For Swing Augers

CURRENT AUGER

None Manual Electric*

*IF ELECTRIC TARPING SYSTEM, WHICH KIND:

Rocker SMART2™ SMART3™

Adding electric tarping system at same time as ordering the DriveMaxx™ kit. Please enter P/N of tarping system here:

AUGER MAKE _____

YEAR _____

A _____ TRANSITION BOX WIDTH (ACTUAL)

B TUBE DIAMETER

8" 10" 12" 13" 14"

FLANGE Yes No

If yes, enter distance from edge of of flange to pre-existing mounting hole.

C _____

Current Remote: SMART1+™ SMART2™ SMART3™

NOTE: If S1+, you MUST upgrade to: SMART2™ OR SMART3™

NOTE: If S2, remote is NOT included. If S3, remote comes standard.

Non-Remote Controlled (Push-Button) LiteALL™ comes standard.

To Upgrade: SMART2™ LiteALL™ OR

SMART3™ LiteALL™

Use the boxes in the categories at left to provide needed information. By checking correct categories for your particular auger, you will have a better understanding of exactly what you should order.



Shur-Co® Dealer Locator



Drive Maxx™ Landing Page

Call your local dealer for more information or use the QR code at the far left for our Dealer Locator. Or use the QR code for Shur-Co's DriveMaxx™ for more product details on our website.

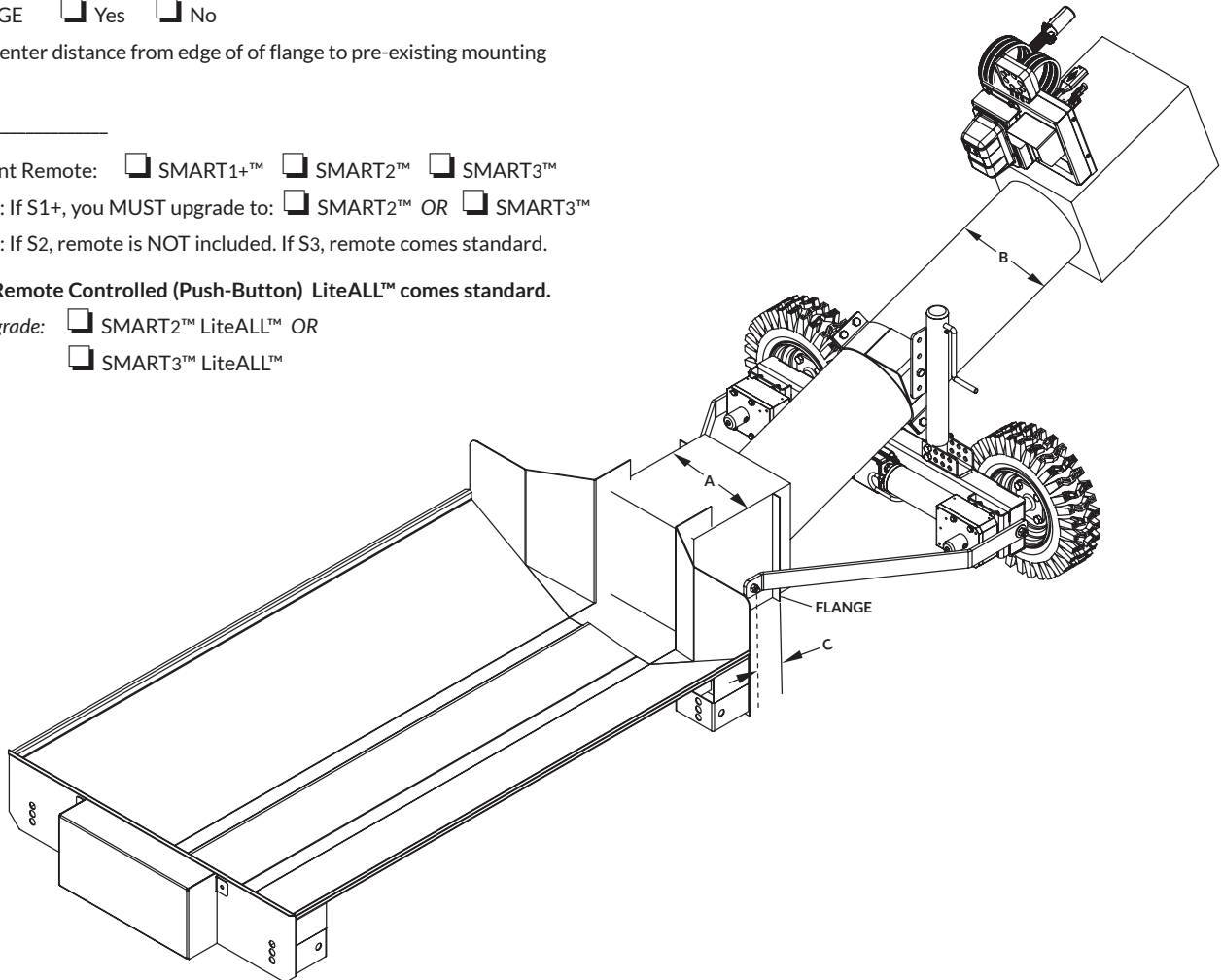

ORDER FORM

Customer ID# _____
 PO# _____ Date _____ Source Code _____
 Name _____
 Address _____ Email _____ Phone _____
 City _____ State _____ Zip _____
 END USER DEALER Ship To _____
 EXTRA TRANSMITTERS* _____ Credit Card Information _____
 *Normally comes with one (1) but programs up to five (5).
NOTE: You receive only one (1) actuator per kit. Exp. Date _____
 Code _____

CURRENT TARPING SYSTEM

NONE ELECTRIC SYSTEM Adding electric tarping system at the same time as ordering Gate & Hoist system. Please enter P/N of tarping system on separate line.
 MANUAL ROCKER SMART2™ SMART3™

Electric Gate & Hoist

BOX MAKE _____

BOX DIMENSIONS
 A _____ Upper Box Length
 B _____ Upper Box Width
 N _____ Top Rail Width
 U _____ Inside Box Width
 X _____ Outside Box Height from Ground

REMOTE TYPE
 SMART2™
 SMART1 +™

HOIST TYPE
 Air-Over Hydraulic
 Yes No - Electric Gate & Hoist N/A.
 Style _____

BOX STYLE | See Figure 1
 Type C Type D Type E
 Other _____

GATE STYLE
 Flat Ribbed

MANUALLY CONTROLLED AIR SWITCH
 Yes No

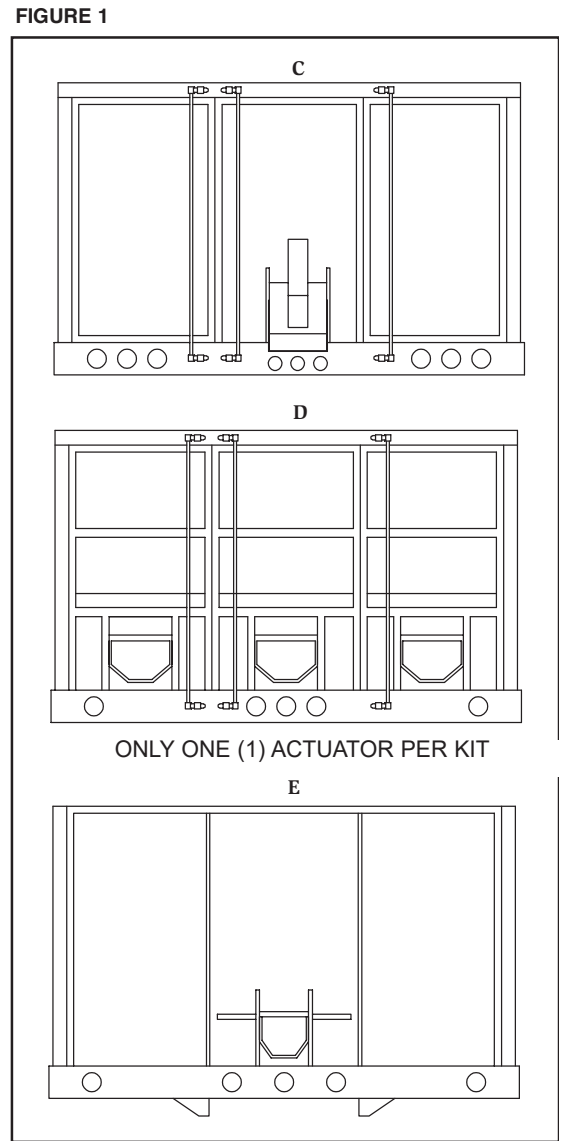
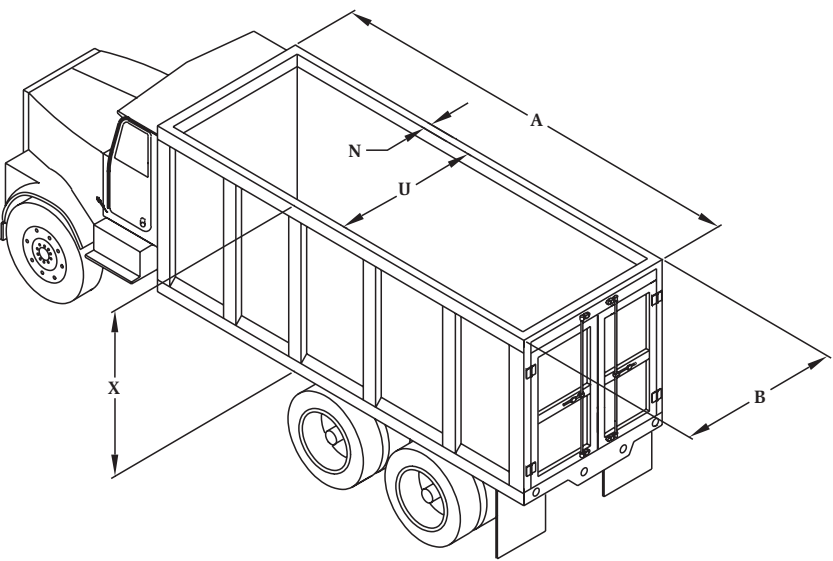

Check out our Genuine Shur-Co® replacement parts, professionally engineered in compliance with the most stringent safety standards. All have excelled in rigorous field testing and are proven to fit and function better.

Shur-Co's strict quality and tolerance guidelines promote dependable product interchangeability. For example, even if a Shur-Lok® is 20 years old, new Shur-Lok® parts are guaranteed to fit. Remember that utilizing non-Genuine parts voids your warranty.

NOTE: All components other than standard may require non-refundable engineering/manufacturing fees. Call for details.

REPLACEMENT PARTS INDEX

TARP REPAIR SUPPLIES 37

SHUR-LOK® ELECTRIC

 Cab Wiring Kits 38

 Dual Conductors 38

 Front Arms 39

 Front/Rear Returns 40

 Receiver/Remote Non Express 41

4500 SERIES HD ELECTRIC

 Cab Wiring Kits 42

 Dual Conductors 42

 Front Arm Assemblies 43-44

 Rear Arm Assemblies 44

 Rear Hinge Assemblies 45-46

 Rear Returns 47

 Receiver/Remote Non Express 48

 Receiver/Remote Express Mode 49

 Pivot Mount Brackets 50

 Trailer Wiring Kits 50

AUTOTRAP™

 SMARTwire™ Hopper Door Openers 51

MAXXTRAP™

 Crank Arms/Crank Retainers 52

 SMARTwire™ Hopper Door Openers 52

PROTRAP®

 Rail Mount Assemblies 53

 SMARTwire™ Hopper Door Openers 53

AUTOTRAP™/MAXXTRAP™/PROTRAP®

 Cab Wiring Kits 54

 SMARTwire™ Electrical 55

AUTOTRAP™/PROTRAP®

 Trailer Mounts 55

DRIVEMAXX™

 DriveMaxx™ Kits 56

 DriveMaxx™ Electrical 57

ELECTRIC GATE AND HOIST 58

AUTOGATE™ 58

ELECTRIC TURNING POINT™ BOW 59

TARP REPAIR SUPPLIES

ITEM	PART #	DESCRIPTION
	1108059	Professional Tarp Repair Kit*
	1102111	Standard Tarp Repair Kit*
	1703251	Handi Grommet Kit w/Grommets
1	1111869	2" x 3" Patch w/Radius Corners
2	1111870	3" x 4" Patch w/Radius Corners
3	1111871	4" x 5" Patch w/Radius Corners
4	1111872	3" Round Patch
5	1701391	Wooden Roller
6	1128714	Vinyl Tarp Remnant - Black
	1107371	Vinyl Tarp Remnant (specify color)
7	1700697	HH-66 Thinner - Pint
8	1700602	HH-66 Thinner - Gallon
9	1700356	HH-66 Vinyl Cement - 8 Oz.
10	1700355	HH-66 Vinyl Cement - Quart
11	1700354	HH-66 Vinyl Cement - Gallon
12	1700673	#3 Brass Grommet (minimum order 25)
	1706352	Vinyl Repair Tape - 6" x 50' (not shown)
	1128814	Tarp Repair Kit w/Vinyl Tape - 6" x 10' (not shown)

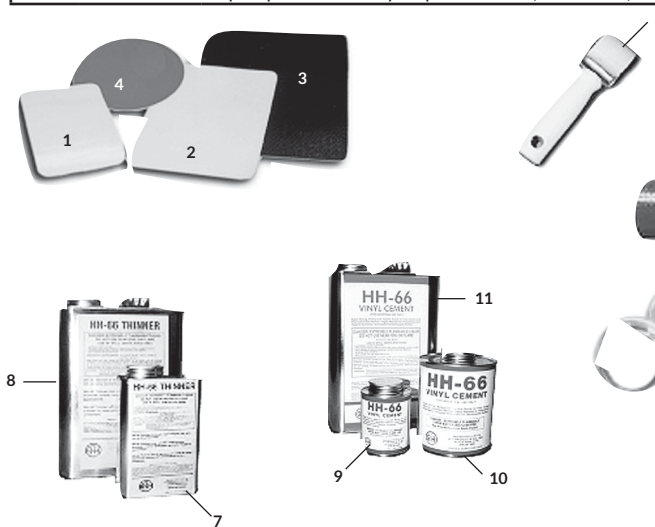

PROFESSIONAL KIT
INCLUDES SCISSORS,
10 SQ. FT. REPAIR FABRIC, ROLLER,
HEAT GUN/NOZZLE
AND INSTRUCTIONS



STANDARD KIT
INCLUDES 1 PT. THINNER,
1 QT. CEMENT, INSTRUCTIONS
AND 10 SQ. FT. REPAIR FABRIC



GROMMET KIT
INCLUDES CUTTER,
HANDLE, BASE,
GROMMETS
AND WASHERS



Tarp Repair
Video

Shur-Co® has created a number of how-to videos, with QR codes to take you right to them. The one pictured here links to step-by-step instructions on tarp repair.

Download any QR scanner app to your Smartphone. Open the app, then hover your phone over your chosen QR code.

SHUR-LOK® ELECTRIC - CAB WIRING KITS

ITEM	PART #	DESCRIPTION
WIRELESS OPTION		
1116928		Cab Wiring Kit - 40 Amp - Wireless - 20' [Includes 1; 7; 10; 2 of 2 & 4; 15 of 16]
1119643		Cab Wiring Kit - 40 Amp - Wireless - 30' [Includes 1; 7; 10; 2 of 2 & 4; 15 of 16]
ROCKER SWITCH OPTION		
1116473		Cab Wiring Kit - 40 Amp - Rocker Switch - 20' [Includes 1; 5; 7; 8; 9; 10; 11; 12; 14; 2 of 4, 13 & 15; 4 of 2; 5 of 6; 6 of 3; 15 of 16]
1128926		Cab Wiring Kit - 80 Amp SMART Circuit Breaker - Rocker - 20' [Includes 1; 5; 7; 8; 9; 10; 11; 12; 14; 17; 2 of 4, 13, 15; 4 of 2; 5 of 6; 6 of 3; 15 of 16]
1118368		Electrical Part Kit w/Rocker Switch - 40 Amp Modified [Includes 5; 7; 8; 9; 12; 14; 2 of 4, 13 & 15; 4 of 2; 5 of 6; 6 of 3]
1128925		Electrical Parts Kit w/Rocker Switch - 80 Amp SMART Circuit Breaker [Includes 5; 7; 8; 9; 12; 14; 17; 2 of 4, 13, 15; 4 of 2; 5 of 6; 6 of 3]
ELECTRICAL COMPONENTS		
1120855		Breaker Hardware [Includes 7; 2 of 2 & 4; 15 of 16]
1	1115385	Heavy-Duty Dual-Conductor Plug - Vertical Pin
2	1703245	Ring Terminal - 6 Ga. x #10 Stud - Motor/Breaker
3	1702707	Ring Terminal - 6 Ga. x 1/4" Stud - Motor/Solenoid
4	1703244	Ring Terminal - 6 Ga. x 3/8" Stud - Battery
5	1704153	Ring Terminal - 14 Ga. x 1/4" Stud - Solenoid
6	1703659	Push-On Terminal - 14 Ga. x 1/4" Switch/Solenoid
7	1704354	40-Amp Modified Reset Circuit Breaker
8	1116020	Rocker Switch
9	1703661	Rocker Switch Mounting Bracket
10	1119078	Dual-Conductor Wire - 6 Ga. - 20'
	1118495	Dual-Conductor Wire - 6 Ga. - 30'
	1703822	Dual-Conductor Wire - 6 Ga. (per foot)
11	1116482	Electrical Wire - 14 Ga. Lead - 15'
12	1703896	Solenoid Cover
13	1701543	Nylon Lock Hex Nut - 1/4"
14	1703845	Motor-Reversing Solenoid
15	1700381	Hex Head Cap Screw - 1/4" x 1"
16	1703231	Cable Tie - 8"
17	1126784	80-Amp Smart Circuit Breaker Kit

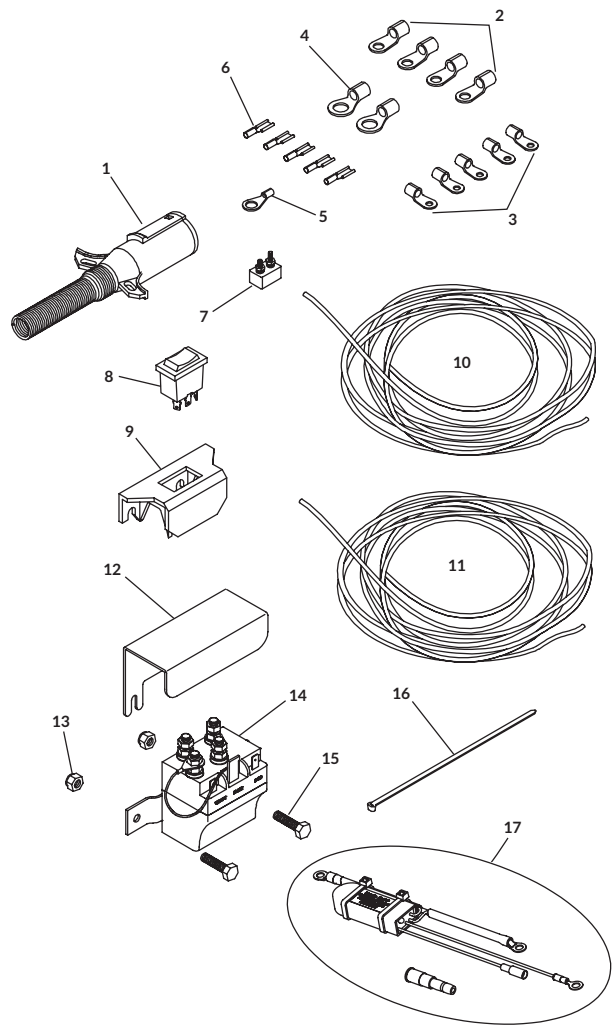

SHUR-LOK® ELECTRIC - DUAL CONDUCTOR KITS

ITEM	PART #	DESCRIPTION
1125580		SMARTwire™ Dual-Connector Socket w/Hardware [Includes 1; 13; 17; 2 of 3, 10 & 11]
1109016		Two-Pole Connector w/Hardware - Vertical Pin [Includes 2; 4; 6; 14; 2 of 3, 7, 8, 9 & 12]
1109017		Dual-Conductor Hardware [Includes 2 of 3, 7, 8, 10, 11 & 12]
1	1120670	SMARTwire™ Dual-Conductor Socket - 6 Ga. x 3'6"
	1126944	SMARTwire™ Dual-Conductor Socket - 4 Ga. x 3'6"
2	1115385	Heavy-Duty Dual-Conductor Plug - Vertical Pin
3	1701045	Hex Head Cap Screw - 5/16" x 3/4"
4	1119557	Heavy-Duty Dual-Conductor Metal Socket w/Boot
5	1704573	Sealing Boot - Socket Half Dual Conductor
6	1109015	Conductor Plug Mounting Bracket
7	1700407	Hex Nut - 3/8"
8	1700434	Lock Washer - 3/8"
9	1700411	Hex Nut - 5/16"
10	1704946	Top Lock Flange Nut - 5/16"
11	1700427	Flat Washer - 1/4"
12	1700400	Self-Tapping Screw - Non Corrosive Coating - 3/8" x 1"
13	1704751	Harness Lock Pin - 1/4" x 7/8"
14	1703231	Cable Tie - 8"
15	1704994	SMARTwire™ - 6 Ga. - Socket - 40'
16	1125597	SMARTwire™ - 6 Ga. - Plug/Socket - 30'
17	1704978	Dual Conductor Poly Housing - Female

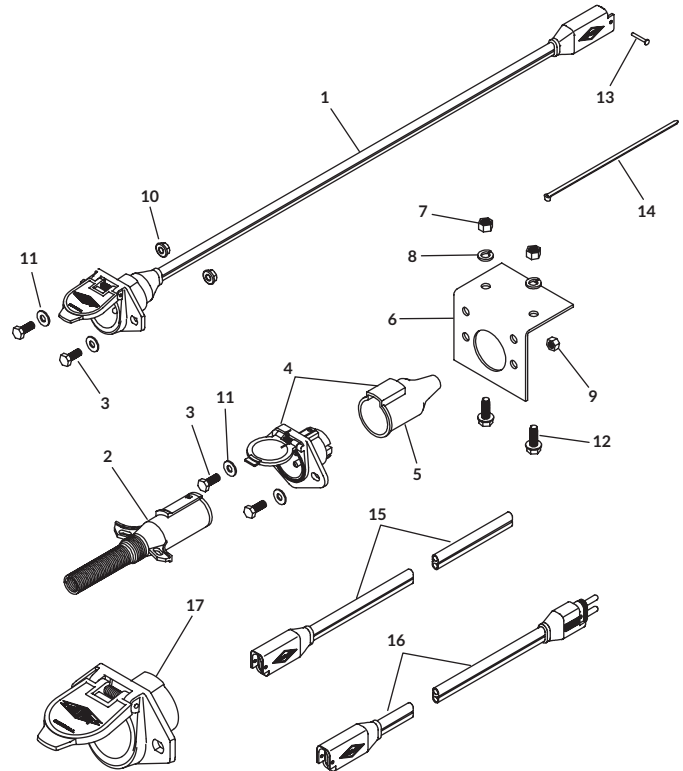

SHUR-LOK® ELECTRIC - FRONT ARMS

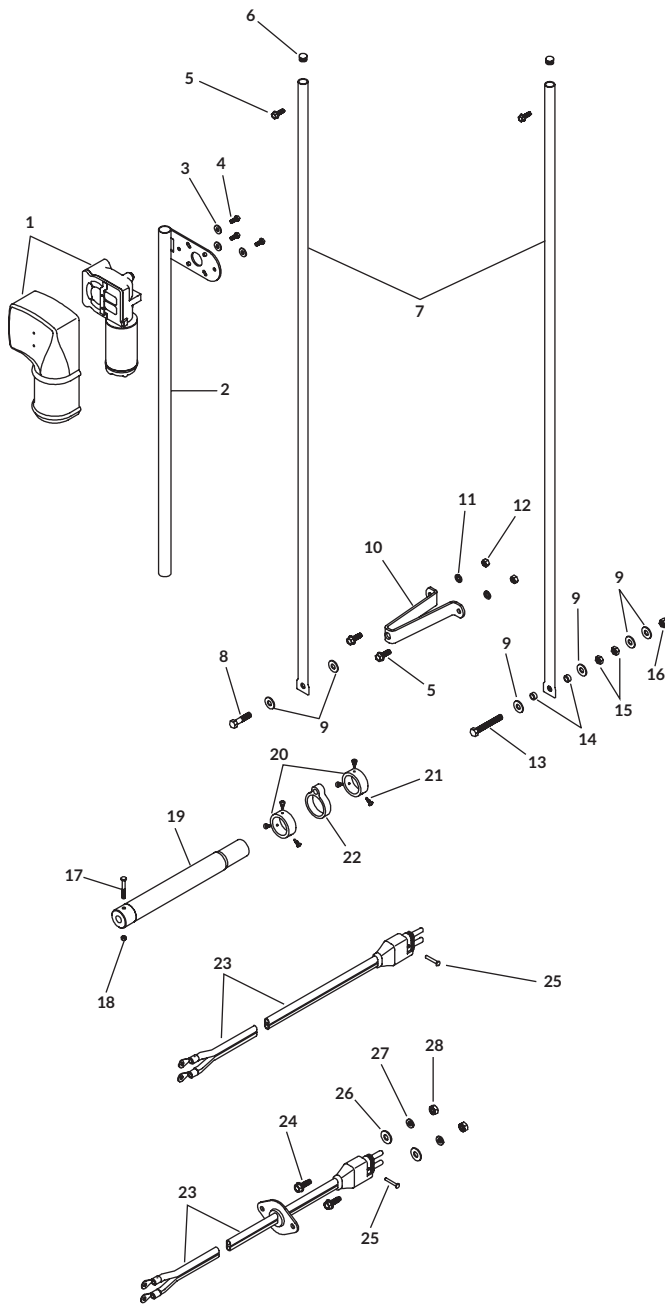

ITEM	PART #	DESCRIPTION
	1120854	Wiring Plate Hardware [Includes 2 of 24, 26, 27 & 28]
1	1704878	Durabuilt™ Motor w/Cover - 3-1/8" Shaft
2	1110413	Slide Arm
	1115559	Stainless Slide Arm
3	1700428	Flat Washer - 5/16"
	1201237	Stainless Flat Washer - 5/16"
4	1701045	Hex Head Cap Screw - 5/16" x 3/4"
	1201269	Stainless Hex Head Cap Screw - 5/16" x 3/4"
5	1700400	Self-Tapping Screw - Non Corrosive Coating - 3/8" x 1"
6	1701595	End Plug - 1"
7	1114954	Swing Arm
	1115558	Stainless Swing Arm
8	1701042	Hex Head Cap Screw - 1/2" x 2"
9	1702114	Flat Washer - 1/2"
10	1100033	Crank Retainer Standoff - 7"
	1115511	Stainless Crank Retainer Standoff - 7"
11	1700434	Lock Washer - 3/8"
12	1700407	Hex Nut - 3/8"
13	1704779	Hex Head Cap Screw - 1/2" x 3"
14	1100306	Retainer Bushing - 11/16"
15	1700413	Jam Nut - 1/2"
16	1702115	Nylon Lock Hex Nut - 1/2"
17	1703237	Hex Head Cap Screw - 5/16" x 2-1/2"
18	1702492	Top Lock Hex Nut - 5/16"
19	1114916	Roll Tube Extension w/Adapter - 17-1/4"
20	1704352	Rear Arm Retaining Collar
21	1705198	Self-Drilling Screw - 1/4" x 1"
22	1114947	Roll Tube Eye
23	1121367	SMARTwire™ w/Plate - 6 Ga. Plug x 1/4" Terminal - 10'9"
	1704987	SMARTwire™ - 6 Ga. Plug x 1/4" Terminal - 10'9"
24	1700403	Self-Tapping Screw - 1/4" x 3/4"
25	1704751	Harness Lock Pin - 1/4" x 7/8"
26	1700427	Flat Washer - 1/4"
27	1700436	Lock Washer - 1/4"
28	1700408	Hex Nut - 1/4"
	1202938	Rubber Grommet - 1-1/2" Insert (not shown)

SHUR-LOK® ELECTRIC - FRONT/REAR RETURNS

ITEM	PART #	DESCRIPTION
CABLE RETURN		
1113025		Rear Cable Return Kit - Heavy Duty [Includes 1; 3; 8; 9; 10; 11; 12; 18; 19; 2 of 7, 13 & 17; 3 of 4, 5, 6 & 20; 4 of 2 & 15; 5 of 14; 7 of 16]
1120650		Front Cable Return Kit - Heavy Duty [Includes 1; 3; 8; 9; 10; 11; 12; 18; 19; 2 of 7, 13 & 17; 3 of 4, 5, 6 & 20; 4 of 2 & 15; 5 of 14; 7 of 16]
1	1702672	Hex Head Cap Screw - 1/4" x 2-1/4"
2	1702654	Machine Screw 1"
3	1701543	Nylon Lock Hex Nut - 1/4"
4	1700400	Self-Tapping Screw - Non Corrosive Coating - 3/8" x 1"
5	1700434	Lock Washer - 3/8"
6	1700407	Hex Nut - 3/8"
7	1702656	Machine Screw - 1-1/2"
8	1114728	Universal Cable Return Housing
9	1115014	Spacer Washer - 1-5/8"
10	1702896	Extension Spring - Heavy Duty
11	1115206	Velcro® Hook- 1" x 4"
12	1114582	Cable w/Return Strap
13	1114691	Front Retainer Plate
14	1703006	Pulley - 1/16" Cable Groove
15	1111056	Plastic Spacer - 3/8"
16	1702653	Machine Screw Nut
17	1112997	Rope Block Retainer Plate
18	1111054	Flat Washer - #10
19	1702655	Machine Screw - 1-1/4"
20	1110913	Rear Retainer Plate
21	1111808	End Plug/Cable Retainer w/Screw
SHOCK CORD RETURN		
1114951		Shock Cord Roll Return Kit [Includes 22; 23; 24; 27; 2 of 4 & 25; 6 of 26]
22	1703445	Shock Cord Eye Bracket
23	1114948	Shock Cord Tie-Down Strap
24	1122332	Shock Cord - 11-1/2"
25	1704352	Rear Arm Retaining Collar
26	1705198	Self-Drilling Screw - 1/4" x 1"
27	1114947	Roll Tube Eye

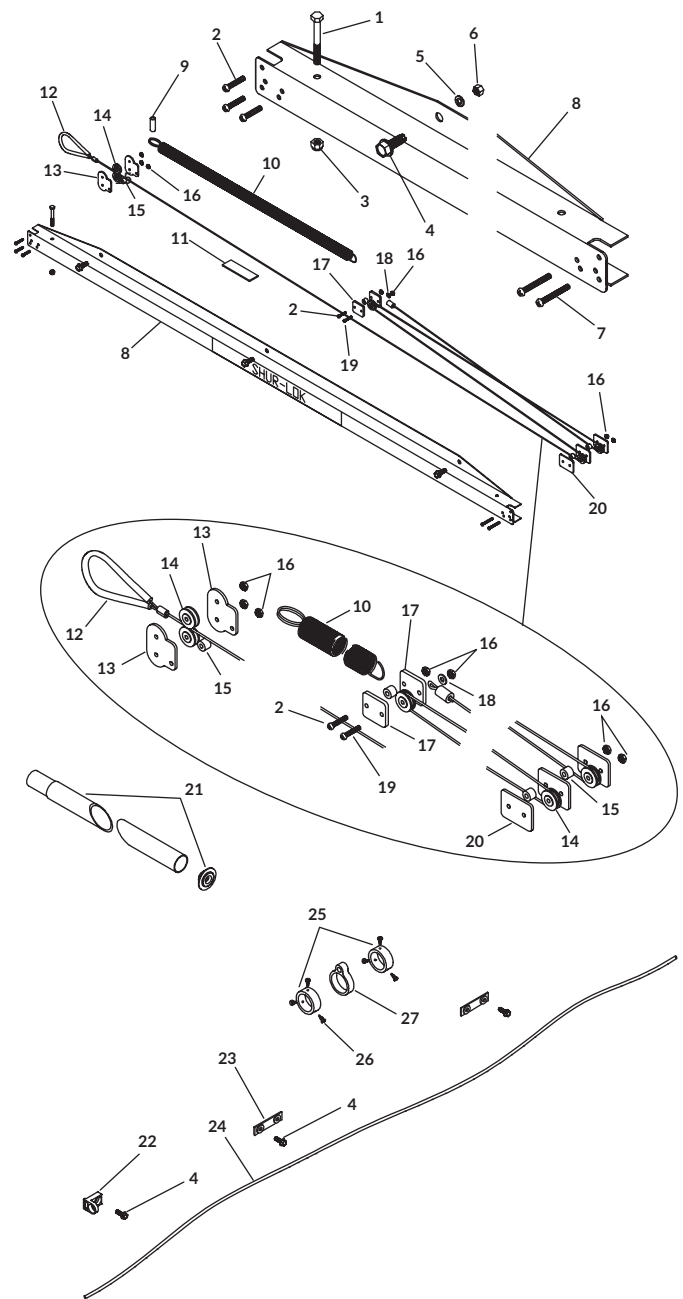

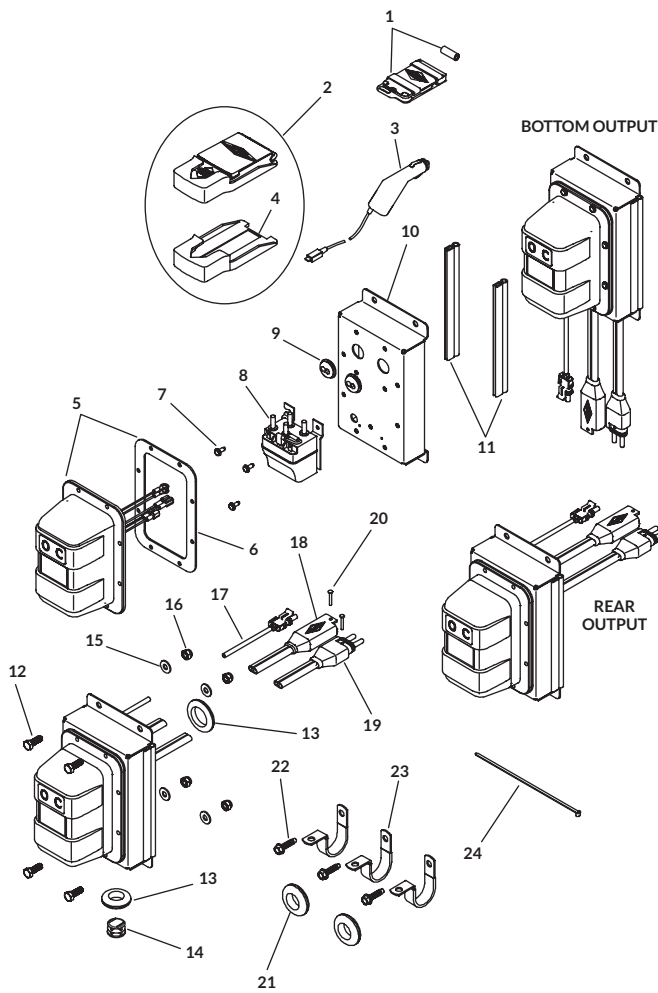

ITEM	PART #	DESCRIPTION
SMART3™ RECEIVERS w/SMARTwire™		
1126885		SMART3™ Receiver w/Remote* - Bottom Output Includes 1; 5; 8; 10; 11; 13; 17; 18; 19; 21; 2 of 9 & 20; 4 of 12, 15, 16, 22 & 23; 11 of 7; 15 of 24]
1126884		SMART3™ Receiver w/Remote* - Rear Output [Includes 1; 5; 8; 10; 11; 13; 14; 17; 18; 19; 21; 2 of 9 & 20; 4 of 12, 15, 16, 22 & 23; 11 of 7; 15 of 24]
1126900		SMART3™ Receiver* - Bottom Output [Includes 5; 8; 10; 11; 13; 17; 18; 19; 21; 2 of 9 & 20; 4 of 12, 15, 16, 22 & 23; 11 of 7; 15 of 24]
1126899		SMART3™ Receiver* - Rear Output [Includes 5; 8; 10; 11; 13; 14; 17; 18; 19; 21; 2 of 9 & 20; 4 of 12, 15, 16, 22 & 23; 11 of 7; 15 of 24]
SMART2™ RECEIVERS w/SMARTwire™		
1127072		SMART2™ Receiver w/Remote* - Bottom Output [Includes 2; 3; 4; 5; 8; 10; 11; 13; 17; 18; 19; 21; 2 of 9 & 20; 4 of 12, 15, 16, 22 & 23; 11 of 7; 15 of 24]
1122788		SMART2™ Receiver w/Remote* - Rear Output [Includes 2; 3; 4; 5; 8; 10; 11; 13; 14; 17; 18; 19; 21; 2 of 9 & 20; 4 of 12, 15, 16, 22 & 23; 11 of 7; 15 of 24]
1125608		SMART2™ Receiver* - Bottom Output [Includes 5; 8; 10; 11; 13; 17; 18; 19; 21; 2 of 9 & 20; 4 of 12, 15, 16, 22 & 23; 11 of 7; 15 of 24]
1127073		SMART2™ Receiver* - Rear Output [Includes 5; 8; 10; 11; 13; 14; 17; 18; 19; 21; 2 of 9 & 20; 4 of 12, 15, 16, 22 & 23; 11 of 7; 15 of 24]
REMOTES		
1	1126867	SMART3™ Remote
	1704569	Carabiner Key Strap (not shown)
2	1122231	SMART2™ Remote w/Cradle
3	1704958	SMART2™ Charging Cable
4	1124305	SMART2™ Remote Cradle
	1124817	Lanyard Ring Kit (not shown)
RECEIVER COMPONENTS		
1120850		Receiver Mounting Hardware** [Includes 21; 2 of 20; 4 of 12, 15, 16, 22 & 23]
1120906		Wire Retaining Hardware** [Includes 4 of 22 & 23]
1120851		Wire Retaining Hardware w/Locking Pin** [Includes 20; 4 of 22 & 23]
5	1126881	SMART3™ Solenoid Cover w/Gasket
	1127074	SMART2™ Solenoid Cover w/Gasket
6	1704309	Solenoid Cover Gasket
7	1704308	Flange Cap Screw - #10 x 1/2"
8	1704312	Motor-Reversing Solenoid
9	1704721	Rubber Grommet w/Slot - .094" x 7/8"
10	1121600	Solenoid Bracket
11	1704369	Trim Seal (per foot)
12	1702926	Hex Head Cap Screw - 5/16" x 7/8"
13	1703282	Rubber Grommet - 1-1/4" Insert
14	1701595	End Plug - 1"
15	1700428	Flat Washer - 5/16"
16	1700419	Nylon Lock Hex Nut - 5/16"
17	1121641	Encoder Wire - 18 Ga. - 6'4" - SMART2™
18	1120817	SMARTwire™ - 6 Ga. - Socket x 1/4" Terminal - 6'3"
19	1704705	SMARTwire™ - 6 Ga. - Plug x 1/4" Terminal - 2'4"
20	1704751	Harness Lock Pin - 1/4" x 7/8"
21	1202938	Rubber Grommet - 1-1/2" Insert
22	1704338	Self-Tapping Screw - 1/4" x 1"
23	1702108	Wire Clip - 3/4" ID
24	1703231	Cable Tie - 8"
	1704378	Dielectric Connector Protector (not shown)

*Receivers include encoder wire but will NOT operate in Express Mode.

**Includes dielectric connector protector.

4500 SERIES HD - CAB WIRING KITS

ITEM	PART #	DESCRIPTION
WIRELESS OPTION		
1116928		Cab Wiring Kit - 40 Amp - Wireless - 20' [Includes 1; 7; 10; 2 of 2 & 4; 15 of 16]
1119643		Cab Wiring Kit - 40 Amp - Wireless - 30' [Includes 1; 7; 10; 2 of 2 & 4; 15 of 16]
1119644		Cab Wiring Kit - 40 Amp - Wireless - 40' [Includes 1; 7; 10; 2 of 2 & 4; 15 of 16]
ROCKER SWITCH OPTION		
1127844		Cab Wiring Kit - 50 Amp SMART Circuit Breaker - Rocker Switch - 20' [Includes 1; 5; 7; 8; 9; 10; 11; 12; 14; 17; 2 of 4, 13 & 15; 4 of 2; 5 of 6; 6 of 3; 15 of 16]
1127845		Cab Wiring Kit - 50 Amp SMART Circuit Breaker - Rocker Switch - 30' [Includes 1; 5; 7; 8; 9; 10; 11; 12; 14; 17; 2 of 4, 13 & 15; 4 of 2; 5 of 6; 6 of 3; 15 of 16]
1118368		Electrical Part Kit w/Rocker Switch - 40 Amp Modified [Includes 5; 7; 8; 9; 12; 14; 2 of 4, 13 & 15; 4 of 2; 5 of 6; 6 of 3]
ELECTRICAL COMPONENTS		
1120855		Breaker Hardware [Includes 7; 2 of 2 & 4; 15 of 16]
1	1115385	Heavy-Duty Dual-Conductor Plug - Vertical Pin
2	1703245	Ring Terminal - 6 Ga. x #10 Stud - Motor/Breaker
3	1702707	Ring Terminal - 6 Ga. x 1/4" Stud - Motor/Solenoid
4	1703244	Ring Terminal - 6 Ga. x 3/8" Stud - Battery
5	1704153	Ring Terminal - 14 Ga. x 1/4" Stud - Solenoid
6	1703659	Push-On Terminal - 14 Ga. x 1/4" Switch/Solenoid
7	1704354	40-Amp Modified Reset Circuit Breaker
8	1116020	Rocker Switch
9	1703661	Rocker Switch Mounting Bracket
10	1119078	Dual-Conductor Wire - 6 Ga. - 20'
	1118495	Dual-Conductor Wire - 6 Ga. - 30'
	1119645	Dual-Conductor Wire - 6 Ga. - 40'
	1703822	Dual-Conductor Wire - 6 Ga. (per foot)
11	1116482	Electrical Wire - 14 Ga. Lead - 15'
12	1703896	Solenoid Cover
13	1701543	Nylon Lock Hex Nut - 1/4"
14	1703845	Motor-Reversing Solenoid
15	1700381	Hex Head Cap Screw - 1/4" x 1"
16	1703231	Cable Tie - 8"
17	1126783	50-Amp SMART Circuit Breaker

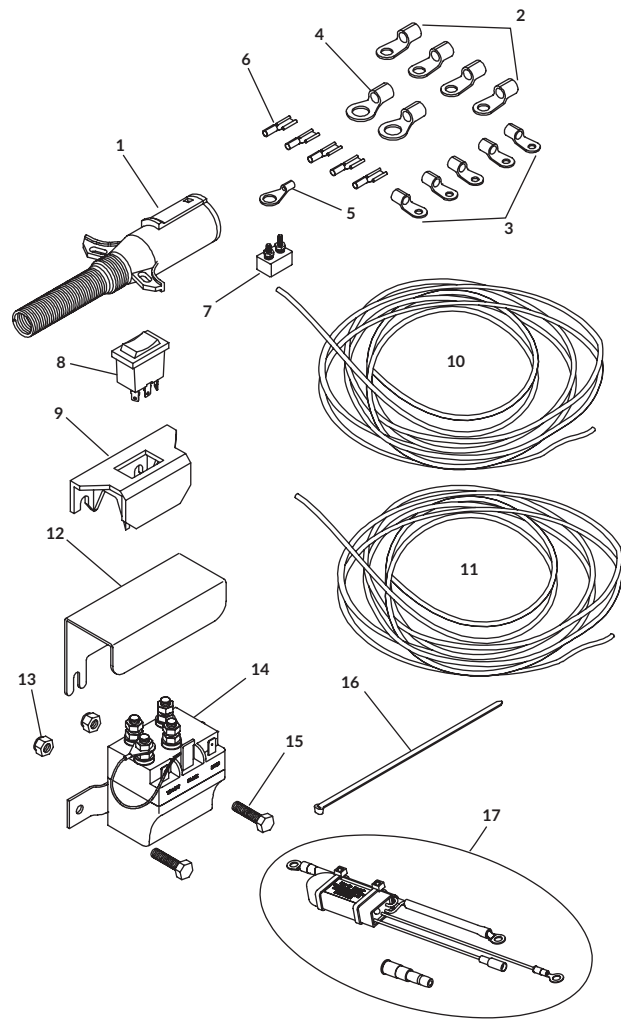

4500 SERIES HD - DUAL CONDUCTOR KITS

ITEM	PART #	DESCRIPTION
1125580		SMARTwire™ Dual-Connector Socket w/Hardware [Includes 1; 13; 2 of 3, 10 & 11]
1109016		Two-Pole Connector w/Hardware - Vertical Pin [Includes 2; 4; 6; 14; 2 of 3, 7, 8, 9 & 12]
1109017		Dual-Conductor Hardware [Includes 2 of 3, 7, 8, 10, 11 & 12]
1	1120670	SMARTwire™ Dual-Conductor Socket
2	1115385	Heavy-Duty Dual-Conductor Plug - Vertical Pin
3	1701045	Hex Head Cap Screw - 5/16" x 3/4"
4	1119557	Heavy-Duty Dual-Conductor Metal Socket w/Boot
5	1704573	Sealing Boot - Socket Half Dual Conductor
6	1109015	Conductor Plug Mounting Bracket
7	1700407	Hex Nut - 3/8"
8	1700434	Lock Washer - 3/8"
9	1700411	Hex Nut - 5/16"
10	1704946	Top Lock Flange Nut - 5/16"
11	1700427	Flat Washer - 1/4"
12	1700400	Self-Tapping Screw - Non Corrosive Coating - 3/8" x 1"
13	1704751	Harness Lock Pin - 1/4" x 7/8"
14	1703231	Cable Tie - 8"
15	1704994	SMARTwire™ - 6 Ga. - Socket - 40'
	1704988	SMARTwire™ - 6 Ga. - Socket - 65'
	1123042	SMARTwire™ - 4 Ga. - Socket - 40'
	1704989	SMARTwire™ - 4 Ga. - Socket - 90'
16	1704978	Dual Conductor Poly Housing - Female

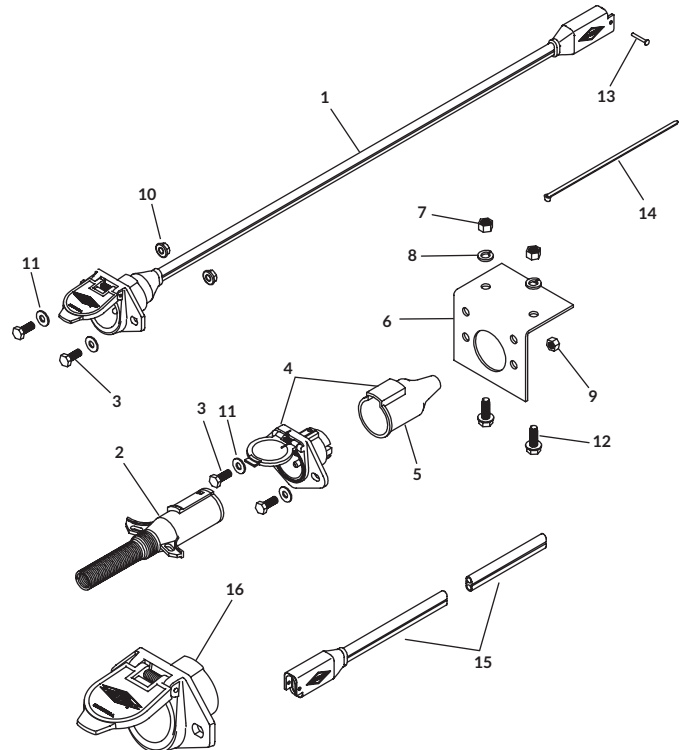

4500 SERIES HD – FRONT ARM ASSEMBLIES

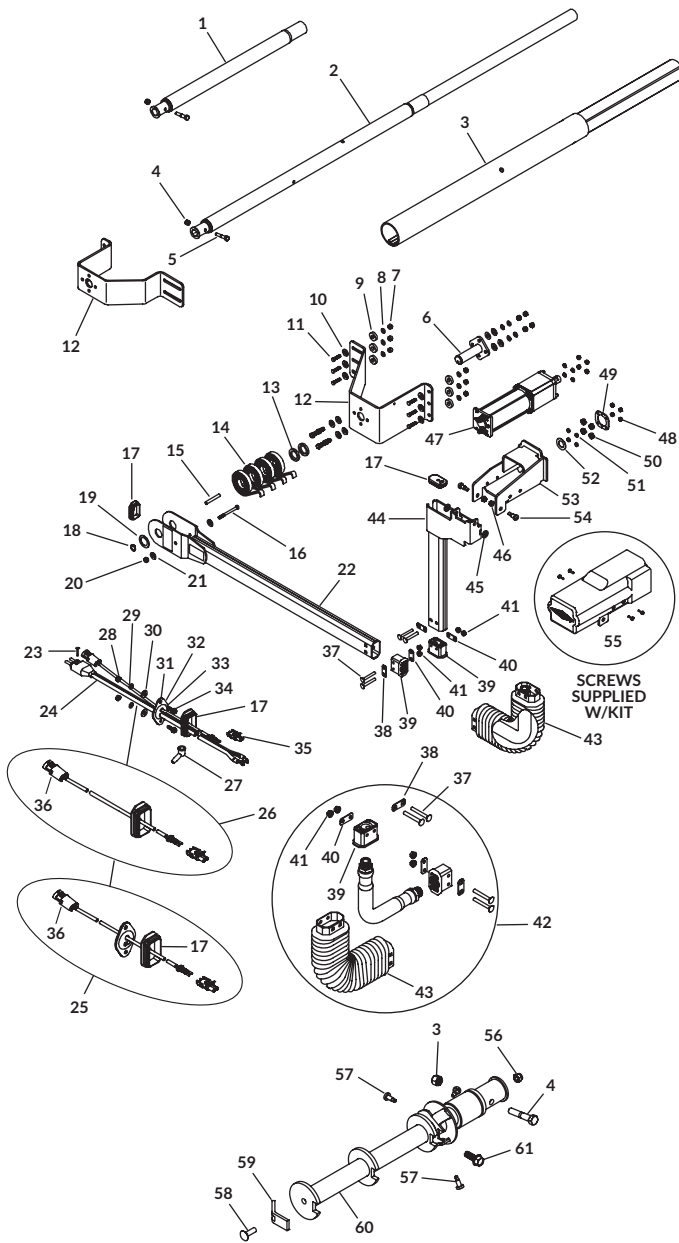

ITEM	PART #	DESCRIPTION
		Front Flex Arm Kit w/o Motor - Grain Trailer
1123928		[Includes 17; 22; 24; 25; 36; 38; 40; 43; 2 of 27, 37 & 41]
		Front Flex Arm Kit w/o Motor - End Dump
1125610		[Includes 17; 22; 24; 25; 36; 38; 40; 43; 2 of 27, 37 & 41]
1122880		Electric Crank Kit - 3"
		[Includes 4; 5; 56; 58; 59; 60; 61; 3 of 57]
1121415		SMARTwire™ Assembly w/Plate - 6 Ga. - Plug x 1/4" Terminal x 10'9" [Includes 24; 25]
1125612		SMARTwire™ Assembly - 6 Ga. - Plug x 1/4" Terminal x 10'9" [Includes 17; 24; 26]
1120977		Motor Mount Hardware [Includes 4; 5; 49; 52; 4 of 48, 50 & 51]
1121702		Flex Arm Joint Hardware [Includes 38; 40; 2 of 37 & 41]
1116926		Spring Support Hardware [Includes 15; 16; 18; 19; 20; 2 of 13 & 21]
1121579		Pivot Bracket Hardware - 6" Vertical [Includes 6 of 9; 10 of 7, 8 & 11; 14 of 10]
1117007		Pivot Bracket Hardware - End Dump [Includes 4 of 11 & 61; 8 of 7 & 8; 12 of 10]
1	1120697	Roll Tube Extension w/Drive Shaft - 34.43"
	1120698	Roll Tube Extension w/Drive Shaft - 45.37"
2	1120699	Roll Tube Extension w/Drive Shaft - End Dump
3	1124901	Roll Tube Extension - 3" x 45"
4	1701580	Nylon Lock Nut - 3/8"
5	1704264	Hex Head Cap Screw - 3/8" x 2"
6	1116920	Pivot Pin - 4 Spring
7	1700407	Hex Nut - 3/8"
8	1700434	Lock Washer - 3/8"
9	1120291	Spacer Washer - 1/4" x 1 OD x .406
10	1700429	Flat Washer - 3/8"
11	1702891	Hex Head Cap Screw - 3/8" x 1-1/4"
12	1121582	Pivot Mount Bracket - 6" x 7-1/4" Standoff
	1121578	Pivot Mount Bracket - 6" x 9-1/4" Standoff
	1116919	Pivot Mount Bracket - 4" x 7-1/4" Standoff
13	1118318	Spacer Washer - 1/4" x 1.81 OD x 1.28"
14	1111027	Spiral Torsion Spring
15	1117033	Spacer Tube - .35" x 2-5/8"
16	1201022	Hex Head Cap Screw - 5/16" x 3-1/2"
17	1704893	Cap Plug w/Hole
18	1702890	Flat Washer - 1-1/4" x 1-7/8"
19	1702888	Retaining Ring - 1-1/4"
20	1700419	Centerlock Hex Nut - 3/8"
21	1700428	Flat Washer - 5/16"
22	1121617	Lower Flex Arm w/Warning Decals - Front
23	1704751	Harness Lock Pin - 1/4" x 7/8"
24	1704987	SMARTwire™ - 6 Ga. - Plug x 1/4" Terminal x 10'9"
25	1121429	SMART2™ Encoder Wire w/Plate - 18 Ga. - 10'6"
26	1121998	SMART2™ Encoder Wire - 18 Ga. - 10'6"
27	1704330	Rubber Insulating Boot
28	1700408	Hex Nut - 1/4"
29	1700436	Lock Washer - 1/4"
30	1700427	Flat Washer - 1/4"
31	1121432	Wiring Plate
32	1704941	Rubber Grommet - 1-1/4"
33	1704828	Wiring Plate Gasket
34	1700403	Self-Tapping Screw - 1/4" x 3/4"
35	1704799	Weatherpack - Cavity Plug
36	1704798	Weatherpack - Tower
37	1701455	Carriage Bolt - 5/16" x 2-1/2" - GR5
38	1121414	Bellow Plate - Square Holes
39	1704891	End Fitting
40	1121413	Bellow Plate - Round Holes
41	1704931	Flanged Nylon Lock Nut - 5/16"
42	1125154	Replacement Flex Arm Joint [Includes Flex Hose; 43; 2 of 38, 39 & 40; 4 of 37 & 41]
43	1704775	Arm Bellow
44	1121289	Upper Flex Arm - Motor
45	1120677	Upper Arm Spacer
46	1701283	Top Lock Flange Nut - 3/8"
47	1120967	4500 Series Motor
48	1701543	Nylon Lock Hex Nut - 1/4"
49	1128243	Motor Mount Bearing Retainer
50	1704736	Radial Ball Bearing - 1/4" x 3/4"
51	1120680	Motor Mount Bearing Spacer
52	1120679	Motor Spacer

Continued on next page

4500 SERIES HD – FRONT ARM ASSEMBLIES Continued

ITEM	PART #	DESCRIPTION
53	1120776	4500 Series HD Motor Mount - 7-1/4"
	1120662	4500 Series HD Motor Mount - 9-1/4"
54	1704778	Shoulder Bolt - 3/8" x 1/2"
55	1121659	Motor Cover Kit - Black
	1128340	Motor Cover Kit - Chrome
56	1704297	Nylon Lock Nut - 5/16"
57	1705198	Self-Drilling Screw - 1/4" x 1"
58	1704237	Carriage Bolt - 5/16" x 1" - GR5
59	1118194	Cartridge Clamp
60	1122264	Drive Shaft - 4500 w/3" Roll Tube
61	1700400	Self-Tapping Screw - Non Corrosive Coating - 3/8" x 1"
FRONT MOUNT KIT*		
	1113002	Front Mount Kit - Sloped [Includes 61; 62; 63; 2 of 64; 16 of 10 & 65; 20 of 60]
62	1113306	Universal Extension Bracket - Passenger Side
63	1113307	Universal Extension Bracket - Driver Side
64	1112178	Front Mounting Bracket - Sloped
65	1112310	Extended Extension Support Bracket
66	1700418	Centerlock Hex Nut - 3/8"

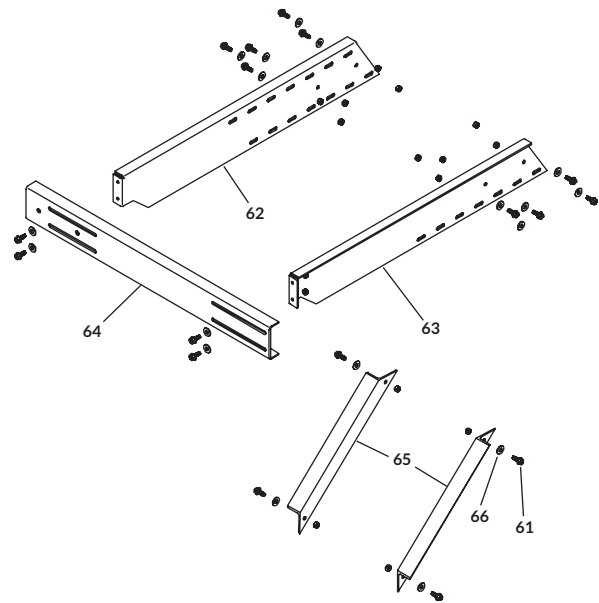

*For sloped trailers in conjunction with vertical mount bracket (P/N 1116919) to help mount pivot brackets on a vertical service. Typically used on end dumps.

4500 SERIES HD – REAR ARM ASSEMBLIES

ITEM	PART #	DESCRIPTION
	1123929	Rear Flex Arm Kit [Includes 17; 24; 25; 27; 28; 2 of 16, 19 & 21; 4 of 18 & 26; 8 of 22]
	1121702	Flex Arm Joint Hardware [Includes 19; 21; 2 of 18 & 22]
	1116926	Spring Support Hardware [Includes 10; 11; 13; 14; 15; 2 of 8 & 12]
	1121579	Pivot Bracket Hardware - 6" Vertical [Includes 10 of 1, 2 & 6; 6 of 5; 14 of 3]
	1121723	Exposed Spline/Bearing Hardware [Includes 26; 27; 2 of 16, 19, 20, 21, 22 & 28; 4 of 18 & 25; 8 of 22]
	1127149	Rear Arm Collar Kit [Includes 28; 2 of 29]
	1127150	Rear Arm Collar Kit* [Includes 28; 2 of 29]
1	1700407	Hex Nut - 3/8"
2	1700434	Lock Washer - 3/8"
3	1700429	Flat Washer - 3/8"
4	1116920	Pivot Pin - 4 Spring
5	1120291	Spacer Washer - 1/4" x 1 OD x .406
6	1702891	Hex Head Cap Screw - 3/8" x 1-1/4"
7	1121582	Pivot Mount Bracket - 6" x 7-1/4" Standoff
	1121578	Pivot Mount Bracket - 6" x 9-1/4" Standoff
8	1118318	Spacer Washer - 1/4" x 1.81 OD x 1.28"
9	1111027	Spiral Torsion Spring
10	1117033	Spacer Tube - .35" x 2-5/8"
11	1201022	Hex Head Cap Screw - 5/16" x 3-1/2"
12	1700428	Flat Washer - 5/16"
13	1700419	Centerlock Hex Nut - 3/8"
14	1702890	Flat Washer - 1-1/4" x 1-7/8"
15	1702888	Retaining Ring - 1-1/4"
16	1704892	Cap Plug
17	1121294	Lower Flex Arm w/Warning Decals - Rear
18	1701455	Carriage Bolt - 5/16" x 2-1/2" - GR5
19	1121414	Bellow Plate - Square Holes
20	1704891	End Fitting
21	1121413	Bellow Plate - Round Holes
22	1704931	Flanged Nylon Lock Nut - 5/16"
23	1125154	Replacement Flex Arm Joint - 4500 HD [Includes Flex Hose; 24; 2 of 19, 20 & 21; 4 of 18]
24	1704775	Arm Bellow
25	1121293	Upper Flex Arm - Bearing
	1124796	Upper Flex Arm - Bearing* - 3"
26	1704943	Shoulder Bolt - 3/8" x 2" Thread x 5/16" x 1/2"
27	1121430	Bearing Mount Box
	1123248	Bearing Mount Box* - 3"
28	1704942	Rear Arm Bearing Ring
	1705160	Rear Arm Bearing Ring* - 3"
29	1706103	Blind Rivet** - 3/16"

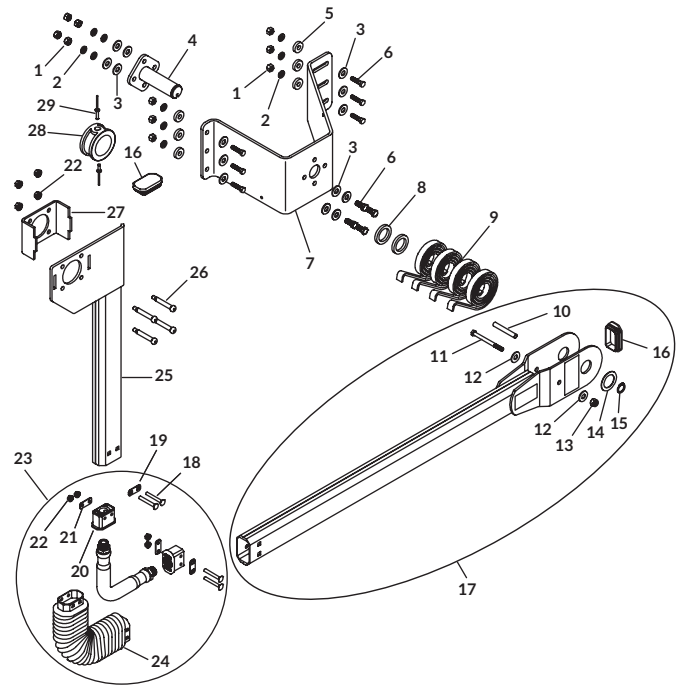

*Used with 3" roll tubes.

**Used with both 2" and 3" roll tubes.

4500 SERIES HD – REAR SIDE HINGE ASSEMBLIES

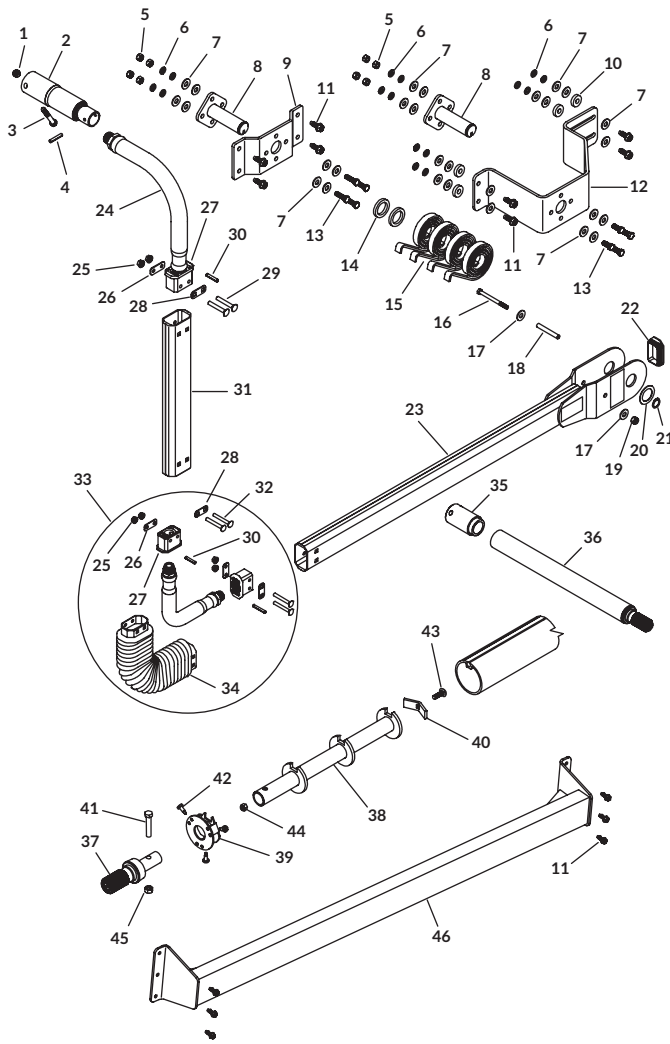

ITEM	PART #	DESCRIPTION
	1117022	Manual Override Extension Kit [Includes 35; 36]
	1122879	Manual Crank Kit - 3" [Includes 11; 37; 38; 39; 40; 41; 43; 44; 45; 3 of 42]
	1121702	Flex Arm Joint Hardware [Includes 26; 28; 2 of 25 & 32]
	1121737	Rear Flex Arm Hardware - Side Hinge [Includes 1; 3; 4; 26; 28; 2 of 25, 29 & 30]
	1116926	Spring Support Hardware [Includes 16; 18; 19; 20; 21; 2 of 14 & 17]
	1116946	Pivot Bracket Hardware - 4" Vertical [Includes 4 of 10; 8 of 5, 6 & 13; 12 of 7]
1	1700418	Centerlock Hex Nut - 3/8"
2	1117777	Roll Tube Bearing Pack
3	1702573	Hex Head Cap Screw - 3/8" x 2-1/2"
4	1700445	Spring Pin - 1/4" x 1-1/2"
5	1700407	Hex Nut - 3/8"
6	1700434	Lock Washer - 3/8"
7	1700429	Flat Washer - 3/8"
8	1116920	Pivot Pin - 4 Spring
9	1117767	Pivot Bracket
10	1120291	Spacer Washer - 1/4" x 1" OD x .406"
11	1700400	Self-Tapping Screw - Non Corrosive Coating - 3/8" x 1"
12	1116919	Pivot Mount Bracket - 4" x 7-1/4" Standoff
13	1702891	Hex Head Cap Screw - 3/8" x 1-1/4"
14	1118318	Spacer Washer - 1/4" x 1.81" OD x 1.28"
15	1111027	Spiral Torsion Spring
16	1201022	Hex Head Cap Screw - 5/16" x 3-1/2"
17	1700428	Flat Washer - 5/16"
18	1117033	Spacer Tube - .35" x 2-5/8"
19	1700419	Nylon Lock Hex Nut - 5/16"
20	1702890	Flat Washer - 1-1/4"
21	1702888	Retaining Ring - 1-1/4"
22	1704892	Cap Plug
23	1121294	Lower Flex Arm w/Warning Decals - Rear
24	1121680	Upper Flex Arm Joint - Side Hinge
25	1704931	Flanged Nylon Lock Nut - 5/16"
26	1121413	Bellow Plate - Round Holes
27	1706260	End Fitting - Aluminum
28	1121414	Bellow Plate - Square Holes
29	1704971	Carriage Bolt - 5/16" x 2-1/4" - GR5
30	1704966	Spring Pin - 1/4" x 1-3/8"
31	1121738	Upper Flex Arm - Side Hinge
32	1701455	Carriage Bolt - 5/16" x 2-1/2" - GR5
33	1128831	Replacement Flex Arm Joint - Aluminum [Includes Flex Hose; 34; 2 of 26, 27, 28 & 30; 4 of 25 & 32]
34	1704775	Arm Bellow
35	1117020	Manual Override Spline Connector
36	1117023	Manual Override Spline Assembly
37	1121111	Manual Crank Spline - 3"
38	1121039	Rear Cartridge
39	1121040	Roll Tube End Cap - Rear
40	1118194	Cartridge Clamp
41	1704264	Hex Head Cap Screw - 3/8" x 2"
42	1705198	Self-Drilling Screw - 1/4" x 1"
43	1704237	Carriage Bolt - 5/16" x 1" - GR5
44	1704297	Nylon Lock Nut - 5/16"
45	1701580	Nylon Lock Nut - 3/8"
46		Beam Bracket - Live Bottom Trailers

4500 SERIES HD - REAR TOP HINGE ASSEMBLIES

ITEM	PART #	DESCRIPTION
	1126477	Rear Flex Arm Kit - Top Hinge* [Includes Flex Hose; 4; 17; 20; 25; 33; 4 of 9]
	1117022	Manual Override Extension Kit [Includes 35; 36]
	1122879	Manual Crank Kit - 3" [Includes 11; 21; 37; 38; 39; 40; 41; 43; 44; 3 of 42]
	1121702	Flex Arm Joint Hardware [Includes 27; 29; 2 of 26 & 30]
	1116926	Spring Support Hardware [Includes 10; 12; 13; 14; 15; 2 of 8 & 11]
	1117007	Pivot Bracket Hardware - End Dump [Includes 4 of 7; 8 of 1 & 2; 12 of 3]
	1116946	Pivot Bracket Hardware - 4" Vertical [Includes 4 of 7; 8 of 1 & 2; 12 of 3]
	1121736	Extension Hardware - Gate Flex™ [Includes 13; 18; 19; 22; 28; 32; 2 of 16, 21, 23 & 24]
	1121647	HD Flex Joint Hardware [Includes 2 of 27 & 29; 4 of 26 & 30]
1	1700407	Hex Nut - 3/8"
2	1700434	Lock Washer - 3/8"
3	1700429	Flat Washer - 3/8"
4	1116920	Pivot Pin - 4 Spring
5	1116919	Pivot Mounting Bracket - 7-1/4" Standoff
	1116994	Pivot Bracket - Sloped - Gate Flex™**
6	1700400	Self-Tapping Screw - Non Corrosive Coating - 3/8" x 1"
7	1702891	Hex Head Cap Screw - 3/8" x 1-1/4"
8	1118318	Spacer Washer - 1/4" x 1.81" OD x 1.28"
9	1111027	Spiral Torsion Spring
10	1201022	Hex Head Cap Screw - 5/16" x 3-1/2"
11	1700428	Flat Washer - 5/16"
12	1117033	Spacer Tube - .35" x 2-3/8"
13	1700419	Nylon Lock Hex Nut - 5/16"
14	1702888	External Retaining Ring - 1-1/4"
15	1702890	Flat Washer - 1-1/4"
16	1704892	Cap Plug
17	1121294	Lower Flex Arm w/Warning Decals - Rear
	1121999	Lower Arm Assembly
18	1700418	Centerlock Hex Nut - 3/8"
19	1702573	Hex Head Cap Screw - 3/8" x 2-1/2"
20	1116990	Gate Flex™
21	1701580	Nylon Lock Hex Nut - 3/8"
22	1703487	Hex Head Cap Screw - 5/16" x 1-1/2"
23	1704703	Flange Bearing - 20mm - 2 Bolt
24	1704264	Hex Head Cap Screw - 3/8" x 2"
25	1121649	Upper Flex Arm - Gate Flex™
26	1704931	Flanged Nylon Lock Nut - 5/16"
27	1121413	Bellow Plate - Round Holes
28	1706260	End Fitting - Aluminum
29	1121414	Bellow Plate - Square Holes
30	1701455	Carriage Bolt - 5/16" x 2-1/2"
31	1704966	Spring Pin - 1/4" x 1-3/8"
32	1701360	Spring Pin - 1/4" x 1-3/4"
33	1128831	Replacement Flex Arm Joint - Aluminum [Includes Flex Hose; 34; 2 of 27, 28, 29 & 31; 4 of 26 & 30]
34	1704775	Arm Bellow
35	1117020	Manual Override Spline Connector
36	1117023	Manual Override Spline Assembly
37	1121111	Manual Crank Spline - 3"
38	1121039	Rear Cartridge
39	1121040	Roll Tube End Cap - Rear
40	1118194	Cartridge Clamp
41	1704264	Hex Head Cap Screw - 3/8" x 2"
42	1705198	Self-Drilling Screw - 1/4" x 1"
43	1704237	Carriage Bolt - 5/16" x 1" - GR5
44	1704297	Nylon Lock Nut - 5/16"
45		Beam Bracket - Live Bottom Trailers

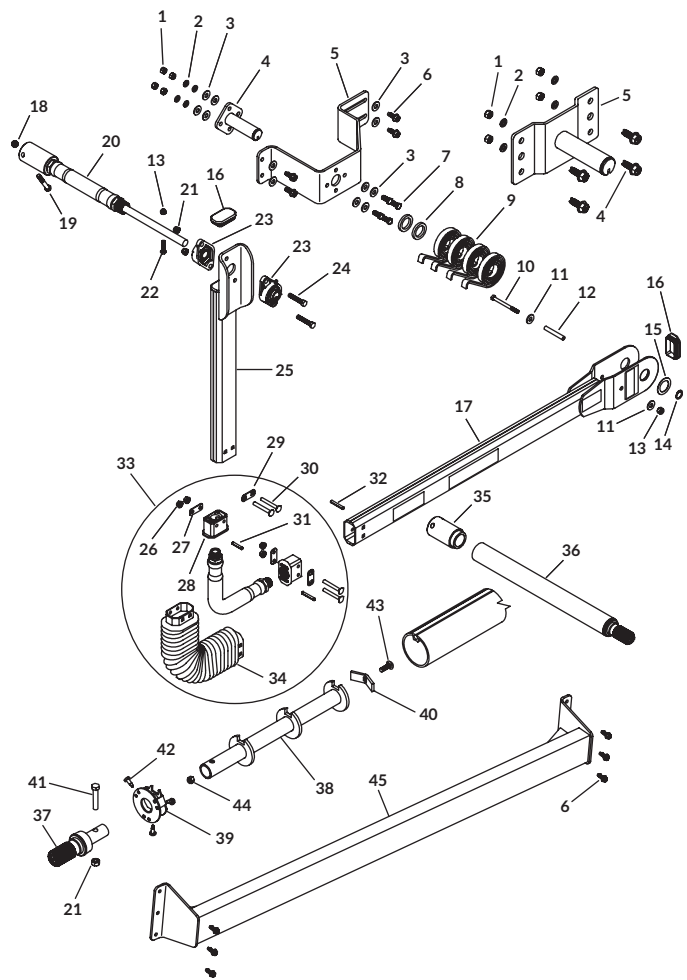

*Does NOT include manual override.

**Gate Flex™ pivot bracket P/N 1116994 is used in conjunction with live-bottom beam bracket. Typically used on trailers with knife gates.

4500 SERIES HD - REAR RETURNS

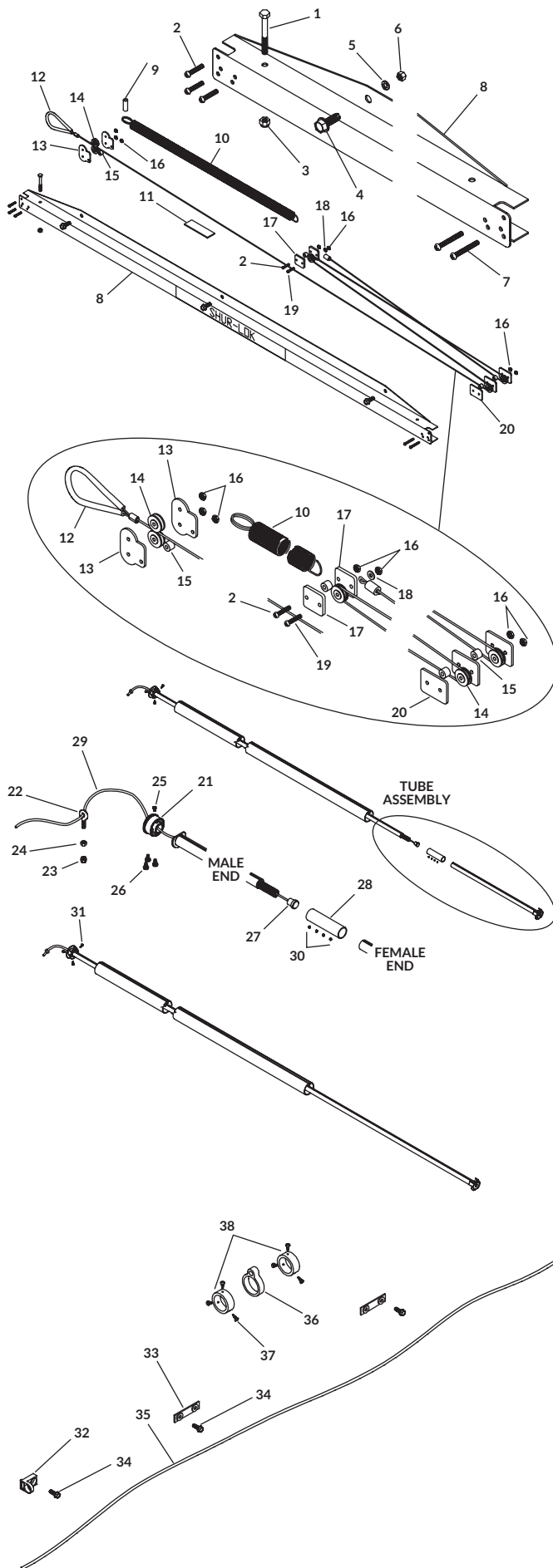

ITEM	PART #	DESCRIPTION
REAR CABLE RETURN		
	1113025	Rear Cable Return Kit - Heavy Duty [Includes 1; 3; 8; 9; 10; 11; 12; 18; 19; 2 of 7, 13 & 17; 3 of 4, 5, 6 & 20; 4 of 2 & 15; 5 of 14; 7 of 16]
	1125581	Rear Cable Return Kit* - Heavy Duty - 3" [Includes 1; 3; 8; 9; 10; 11; 12; 18; 19; 2 of 7, 13 & 17; 3 of 4, 5, 6 & 20; 4 of 2 & 15; 5 of 14; 7 of 16]
	1111469	Cable Return Mounting Hardware [Includes 3 of 4, 5 & 6]
1	1702672	Hex Head Cap Screw - 1/4" x 2-1/4"
2	1702654	Machine Screw - 1"
3	1701543	Nylon Lock Hex Nut - 1/4"
4	1700400	Self-Tapping Screw - Non Corrosive Coating - 3/8" x 1"
5	1700434	Lock Washer - 3/8"
6	1700407	Hex Nut - 3/8"
7	1702656	Machine Screw - 1-1/2"
8	1114728	Universal Cable Return Housing
9	1115014	Spacer Washer - 1-5/8"
10	1702896	Extension Spring - Heavy Duty
11	1115206	Velcro® Hook - 1" x 4"
12	1114582	Cable w/Return Strap
	1124870	Cable w/Return Strap* - 3"
13	1114691	Front Retainer Plate
14	1703006	Pulley - 1/16" Cable Groove
15	1111056	Plastic Spacer - 3/8" Thick
16	1702653	Machine Screw Nut
17	1112997	Rope Block Retainer Plate
18	1111054	Flat Washer - #10
19	1702655	Machine Screw - 1-1/4"
20	1110913	Rear Retainer Plate
REAR SHUR-RETURN™		
	1125119	Shur-Return™ Kit - Heavy Duty [Includes Tube Assembly; 21; 22; 23; 24; 25; 5 of 26]
	1125121	2-Piece Shur-Return™ Kit - Heavy Duty [Includes Tube Assembly; 21; 22; 23; 24; 25; 28; 4 of 30; 5 of 26]
	1125123	Shur-Return™ Kit* - Heavy Duty - 3" [Includes Tube Assembly; 21; 22; 23; 24; 25; 3 of 31; 5 of 26]
	1125125	2-Piece Shur-Return™ Kit** - Heavy Duty - 3" [Includes Tube Assembly; 21; 22; 23; 24; 25; 28; 3 of 31; 4 of 30; 5 of 26]
	1107128	Shur-Return™ Hardware [Includes 21; 22; 23; 24; 25; 5 of 26]
	1124881	Shur-Return™ Hardware* - 3" [Includes 21; 22; 23; 24; 25; 3 of 31; 5 of 26]
21	1100138	Nylon End Plug
22	1700717	Eyebolt Anchor - 5/16"
23	1700419	Centerlock Hex Nut - 3/8"
24	1700411	Hex Nut - 5/16"
25	1704743	Self-Drilling Screw - #10 x 1/2"
26	1700736	Self-Tapping Screw - 1/4" x 1/2"
27	1100827	Spring Retainer Plug
28	1107879	Connector Sleeve
29	1100826	Shur-Return™ Rope***
30	1701423	Hex Socket Set Screw - #10 x 3/16"
31	1705198	Self-Drilling Screw - 1/4" x 1"
SHOCK CORD RETURN		
	1114951	Shock Cord Roll Return Kit [Includes 32; 33; 35; 36; 2 of 34 & 38; 6 of 37]
	1125583	Shock Cord Roll Return Kit* - 3" [Includes 32; 33; 35; 36; 2 of 34 & 38; 6 of 37]
32	1703445	Shock Cord Eye Bracket
33	1114948	Shock Cord Tie-Down Strap
34	1700400	Self-Tapping Screw - Non Corrosive Coating - 3/8" x 1"
35	1122332	Shock Cord - 11-1/2"
36	1114947	Roll Tube Eye
	1705552	Roll Tube Eye* - 3"
37	1705198	Self-Drilling Screw - 1/4" x 1"
38	1704352	Rear Arm Retaining Collar
	1122256	Rear Arm Retaining Collar* - 3"

*Used with 3" roll tubes.

**Additional overlength shipping charges apply.

***Shur-Return™ rope does NOT stretch; see stretch cord on next page.

4500 SERIES HD – RECEIVER/REMOTE Non Express

ITEM	PART #	DESCRIPTION
SMART3™ RECEIVERS w/SMARTWire™		
1126965		SMART3™ Receiver w/Remote* - Bottom Output [Includes 1; 5; 8; 10; 11; 13; 17; 18; 19; 21; 2 of 9 & 20; 4 of 12, 15, 16, 22 & 23; 11 of 7; 15 of 24]
1126966		SMART3™ Receiver w/Remote* - Rear Output [Includes 1; 5; 8; 10; 11; 13; 14; 17; 18; 19; 21; 2 of 9 & 20; 4 of 12, 15, 16, 22 & 23; 11 of 7; 15 of 24]
1126967		SMART3™ Receiver* - Bottom Output [Includes 5; 8; 10; 11; 13; 17; 18; 19; 21; 2 of 9 & 20; 4 of 12, 15, 16, 22 & 23; 11 of 7; 15 of 24]
1126968		SMART3™ Receiver* - Bottom Output [Includes 5; 8; 10; 11; 13; 14; 17; 18; 19; 21; 2 of 9 & 20; 4 of 12, 15, 16, 22 & 23; 11 of 7; 15 of 24]
SMART2™ RECEIVERS w/SMARTWire™		
1122135		SMART2™ Receiver w/Remote* - Bottom Output [Includes 2; 3; 4; 5; 8; 10; 11; 13; 17; 18; 19; 21; 2 of 9 & 20; 4 of 12, 15, 16, 22 & 23; 11 of 7; 15 of 24]
1122041		SMART2™ Receiver w/Remote* - Rear Output [Includes 2; 3; 4; 5; 8; 10; 11; 13; 14; 17; 18; 19; 21; 2 of 9 & 20; 4 of 12, 15, 16, 22 & 23; 11 of 7; 15 of 24]
1127070		SMART2™ Receiver* - Bottom Output [Includes 5; 8; 10; 11; 13; 17; 18; 19; 21; 2 of 9 & 20; 4 of 12, 15, 16, 22 & 23; 11 of 7; 15 of 24]
1122137		SMART2™ Receiver* - Rear Output [Includes 5; 8; 10; 11; 13; 14; 17; 18; 19; 21; 2 of 9 & 20; 4 of 12, 15, 16, 22 & 23; 11 of 7; 15 of 24]
REMOTES		
1	1126867	SMART3™ Remote - Grain Trailer
	1704569	Carabiner Key Strap (not shown)
2	1122231	SMART2™ Remote w/Cradle
3	1704958	SMART2™ Charging Cable
4	1124305	SMART2™ Remote Cradle
	1124817	Lanyard Ring Kit (not shown)
RECEIVER COMPONENTS		
	1120850	Receiver Mounting Hardware** [Includes 21; 2 of 20; 4 of 12, 15, 16, 22 & 23]
	1120906	Wire Retaining Hardware** [Includes 4 of 22 & 23]
	1120851	Wire Retaining Hardware w/Locking Pin** [Includes 20; 4 of 22 & 23]
5	1126880	SMART3™ Solenoid Cover w/Gasket - Non Express
	1122955	SMART2™ Solenoid Cover w/Gasket - Non Express
6	1704309	Solenoid Cover Gasket
7	1704308	Flange Cap Screw - #10 x 1/2"
8	1704312	Motor-Reversing Solenoid
9	1704721	Rubber Grommet w/Slot - .094" x 7/8"
10	1121600	Solenoid Bracket
11	1704369	Trim Seal (per foot)
12	1702926	Hex Head Cap Screw - 5/16" x 7/8"
13	1703282	Rubber Grommet - 1-1/4" Insert
14	1701595	End Plug - 1"
15	1700428	Flat Washer - 5/16"
16	1700419	Nylon Lock Hex Nut - 5/16"
17	1121641	Encoder Wire - 18 Ga. - 6'4" - SMART2™
18	1120817	SMARTWire™ - 6 Ga. - Socket x 1/4" Terminal - 6'3"
19	1704705	SMARTWire™ - 6 Ga. - Plug x 1/4" Terminal - 2'4"
20	1704751	Harness Lock Pin - 1/4" x 7/8"
21	1202938	Rubber Grommet - 1-1/2" Insert
22	1704338	Self-Tapping Screw - 1/4" x 1"
23	1702108	Wire Clip - 3/4" ID
24	1703231	Cable Tie - 8"
	1704378	Dielectric Connector Protector (not shown)

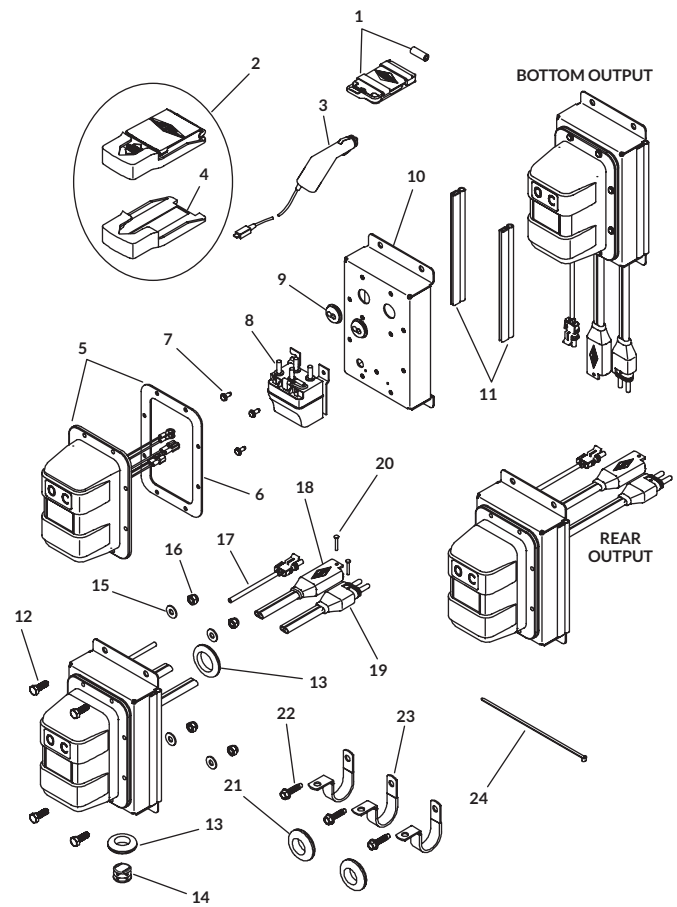

*Receivers marked "Bottom Output" have SMARTWire™ routed through bottom of receiver. Those marked "Rear Output" have SMARTWire™ routed through back of receiver, which is then routed through face of trailer.

**Includes dielectric connector protector.

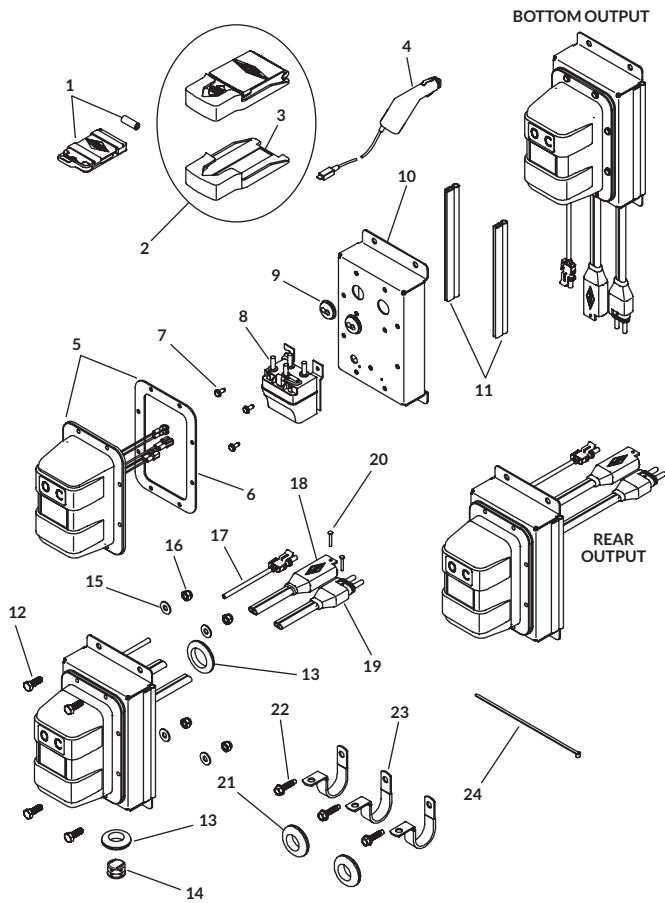

ITEM	PART #	DESCRIPTION
SMART3™ RECEIVERS w/SMARTwire™		
1126863		SMART3™ Receiver w/Remote* - Bottom Output [Includes 1; 5; 8; 10; 11; 13; 17; 18; 19; 21; 2 of 9 & 20; 4 of 12, 15, 16, 22 & 23; 11 of 7; 15 of 24]
1126862		SMART3™ Receiver w/Remote* - Rear Output [Includes 1; 5; 8; 10; 11; 13; 14; 17; 18; 19; 21; 2 of 9 & 20; 4 of 12, 15, 16, 22 & 23; 11 of 7; 15 of 24]
1126866		SMART3™ Receiver* - Bottom Output [Includes 5; 8; 10; 11; 13; 17; 18; 19; 21; 2 of 9 & 20; 4 of 12, 15, 16, 22 & 23; 11 of 7; 15 of 24]
1126860		SMART3™ Receiver* - Rear Output [Includes 5; 8; 10; 11; 13; 14; 17; 18; 19; 21; 2 of 9 & 20; 4 of 12, 15, 16, 22 & 23; 11 of 7; 15 of 24]
SMART2™ RECEIVERS w/SMARTwire™		
1125007		SMART2™ Receiver w/Remote* - Bottom Output [Includes 2; 3; 4; 5; 8; 10; 11; 13; 17; 18; 19; 21; 2 of 9 & 20; 4 of 12, 15, 16, 22 & 23; 11 of 7; 15 of 24]
1125003		SMART2™ Receiver w/Remote* - Rear Output [Includes 2; 3; 4; 5; 8; 10; 11; 13; 14; 17; 18; 19; 21; 2 of 9 & 20; 4 of 12, 15, 16, 22 & 23; 11 of 7; 15 of 24]
1125616		SMART2™ Receiver* - Bottom Output [Includes 5; 8; 10; 11; 13; 17; 18; 19; 21; 2 of 9 & 20; 4 of 12, 15, 16, 22 & 23; 11 of 7; 15 of 24]
1125008		SMART2™ Receiver* - Rear Output [Includes 5; 8; 10; 11; 13; 14; 17; 18; 19; 21; 2 of 9 & 20; 4 of 12, 15, 16, 22 & 23; 11 of 7; 15 of 24]
REMOTES		
1	1126867	SMART3™ Remote - Grain Trailer
	1704569	Carabiner Key Strap (not shown)
	1122108	SMART2™ Remote w/Cradle/Charging Cable [Includes 2; 4]
2	1122231	SMART2™ Remote w/Cradle
3	1124305	SMART2™ Remote Cradle
4	1704958	SMART2™ Charging Cable
	1124817	Lanyard Ring Kit (not shown)
RECEIVER COMPONENTS		
	1120850	Receiver Mounting Hardware** [Includes 21; 2 of 20; 4 of 12, 15, 16, 22 & 23]
	1120906	Wire Retaining Hardware** [Includes 4 of 22 & 23]
	1120851	Wire Retaining Hardware w/Locking Pin** [Includes 20; 4 of 22 & 23]
5	1126873	SMART3™ Solenoid Cover w/Gasket - Express
	1124994	SMART2™ Solenoid Cover w/Gasket - Express
6	1704309	Solenoid Cover Gasket
7	1704308	Flange Cap Screw - #10 x 1/2"
8	1704312	Motor-Reversing Solenoid
9	1704721	Rubber Grommet w/Slot - .094" x 7/8"
10	1121600	Solenoid Bracket
11	1704369	Trim Seal (per foot)
12	1702926	Hex Head Cap Screw - 5/16" x 7/8"
13	1703282	Rubber Grommet - 1-1/4" Insert
14	1701595	End Plug - 1"
15	1700428	Flat Washer - 5/16"
16	1700419	Nylon Lock Hex Nut - 5/16"
17	1121641	Encoder Wire - 18 Ga. - 6'4" - SMART2™
18	1120817	SMARTwire™ - 6 Ga. - Socket x 1/4" Terminal - 6'3"
19	1704705	SMARTwire™ - 6 Ga. - Plug x 1/4" Terminal - 2'4"
20	1704751	Harness Lock Pin - 1/4" x 7/8"
21	1202938	Rubber Grommet - 1-1/2" Insert
22	1704338	Self-Tapping Screw - 1/4" x 1"
23	1702108	Wire Clip - 3/4" ID
24	1703231	Cable Tie - 8"
	1704378	Dielectric Connector Protector (not shown)

*Receivers marked "Bottom Output" have SMARTwire™ routed through bottom of receiver. Those marked "Rear Output" have SMARTwire™ routed through back of receiver, which is then routed through face of trailer.

**Includes dielectric connector protector

4500 SERIES HD – PIVOT MOUNT BRACKETS

ITEM	PART #	DESCRIPTION
	1121579	Pivot Bracket Hardware - 6" Vertical [Includes 6 of 5; 10 of 3, 4 & 6; 14 of 2]
	1121580	Pivot Bracket Hardware - 6" Sloped [Includes 6 of 5; 16 of 3, 4 & 6; 26 of 2]
	1117604	Pivot Pin Hardware [Includes 4 of 3, 4 & 6; 8 of 2]
1	1116920	Pivot Pin - 4 Spring
2	1700429	Flat Washer - 3/8"
3	1700434	Lock Washer - 3/8"
4	1700407	Hex Nut - 3/8"
5	1120291	Spacer Washer - 1/4" x 1" OD x .406"
6	1702891	Hex Head Cap Screw - 3/8" x 1-1/4"
7	1121582	Pivot Mount Bracket - 6" x 7-1/4" Standoff
	1121578	Pivot Mount Bracket - 6" x 9-1/4" Standoff
	1124678	Pivot Mount Bracket - 6" x 10-1/4" Standoff
	1121517	Pivot Mount Bracket - 6" x 12-1/4" Standoff
8	1121993	Pivot Mount Bracket - 6" x 6" Standoff - Sloped
	1121994	Pivot Mount Bracket - 6" x 8" Standoff - Sloped
	1121995	Pivot Mount Bracket - 6" x 10" Standoff - Sloped
	1121586	Pivot Mount Bracket* - 6" x 6" Standoff - Sloped 17°
	1121587	Pivot Mount Bracket* - 6" x 8" Standoff - Sloped 17°
	1121588	Pivot Mount Bracket* - 6" x 10" Standoff - Sloped 17°
9	1121992	Pivot Mount Bracket - Sloped - 6"
10	1700400	Self-Tapping Screw - Non Corrosive Coating - 3/8" x 1"
11	1121583	Pivot Backer Plate - 7" x 16"
	1121584	Pivot Backer Plate - 7" x 20"
	1122040	Pivot Backer Plate - 7" x 24"

*Used on trailers with long, flat sloped front or rear..

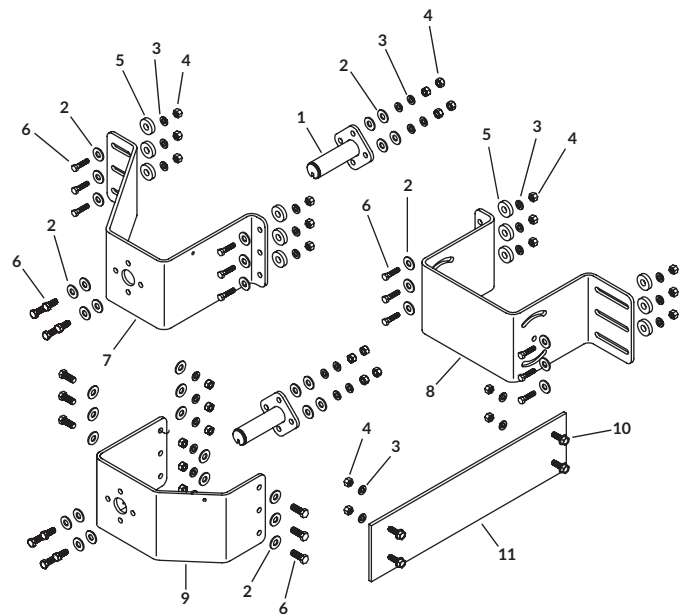

4500 SERIES HD – TRAILER WIRING KITS

ITEM	PART #	DESCRIPTION
	1122536	Lead Trailer Wiring Kit* - SMARTwire™ - 4 Ga. - 33' Trailer [Includes 1; 2; 3; 6; 7; 8; 2 of 4; 12 of 9; 14 of 5; 40 of 10]
	1122537	Lead Trailer Wiring Kit* - SMARTwire™ - 4 Ga. - 42' Trailer [Includes 1; 2; 3; 6; 7; 8; 2 of 4; 12 of 9; 14 of 5; 40 of 10]
	1122538	Lead Trailer Wiring Kit* - SMARTwire™ - 4 Ga. - 50' Trailer [Includes 1; 2; 3; 6; 7; 8; 2 of 4; 12 of 9; 14 of 5; 40 of 10]
	1122533	Lead Trailer Wiring Kit** - SMARTwire™ - 4 Ga. - Combo 33' Trailer [Includes 6; 7; 8; 12 of 5 & 9; 40 of 10]
	1122534	Lead Trailer Wiring Kit** - SMARTwire™ - 4 Ga. - Combo 42' Trailer [Includes 6; 7; 8; 12 of 5 & 9; 40 of 10]
	1122535	Lead Trailer Wiring Kit** - SMARTwire™ - 4 Ga. - Combo 50' Trailer [Includes 6; 7; 8; 12 of 5 & 9; 40 of 10]
	1120849	Junction Block Kit w/Harness Plug [Includes 1; 2; 3; 2 of 4 & 5]
1	1704695	Harness Junction Block
2	1704717	Wire Harness Rubber Plug
3	1704711	Harness Lock Pin - Short
4	1704696	Harness Lock Pin - Long
5	1704338	Self-Tapping Screw - 1/4" x 1"
6	1122541	SMARTwire™ Dual-Conductor Socket - 22'
	1122542	SMARTwire™ Dual-Conductor Socket - 32'
	1122543	SMARTwire™ Dual-Conductor Socket - 40'
7	1704888	SMARTwire™ - 4 Ga. - Plug/Socket - 25'
8	1704720	Wire Harness Seal
9	1702108	Wire Clip - 3/4" ID
10	1703231	Cable Tie - 8"
11	1704978	Dual-Conductor Housing - Female
12	1123957	Coiled Wire w/Dual-Conductor Plugs - 4 Ga. x 15'
	1123958	Coiled Wire w/Dual-Conductor Plugs - 4 Ga. x 20'

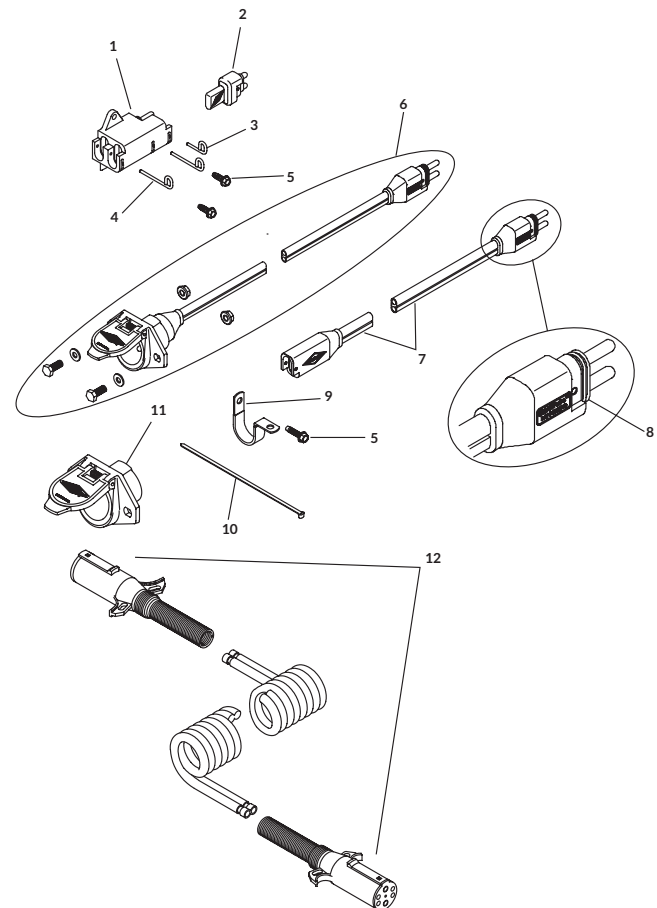

*Lead trailer wiring kit ties into either 4500 Series HD or hopper kits on lead trailer, which routes power to rear of lead trailer.

**Lead trailer wiring kit ties into BOTH 4500 Series HD and hopper kits on lead trailer, which routes power to rear of lead trailer.

AUTOTRAP™ – SMARTWIRE™ HOPPER DOOR OPENERS

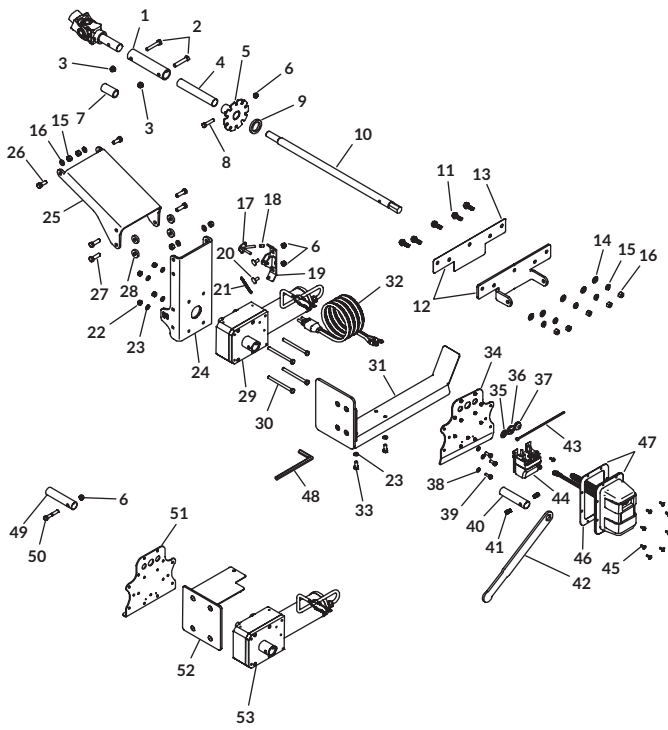

ITEM	PART #	DESCRIPTION
	1123896	Intermediate Bracket Hardware - Rail Mount [Includes 2 of 26; 4 of 27 & 28; 6 of 15 & 16]
	1118253	Hinge Bracket Hardware [Includes 2 of 2 & 27; 4 of 3; 5 of 11, 14, 15 & 16]
1	1123567	Coupling - 1-3/8" x 6"
2	1704264	Hex Head Cap Screw - 3/8" x 2"
3	1701580	Nylon Lock Nut - 3/8"
4	1705226	Adapter Bushing
5	1123565	Manual Locking Gear
6	1700419	Nylon Lock Hex Nut - 5/16"
7	1123569	Shaft Adapter - 3/4" to 1"
8	1703487	Hex Head Cap Screw - 5/16" x 1-1/2"
9	1118318	Spacer Washer - 1/4" x 1.81 OD x 1.28"
10	1124697	Drive Shaft - 27"
11	1700400	Self-Tapping Screw - Non Corrosive Coating - 3/8" x 1"
12	1118439	Replacement Hinge Bracket
13	1118277	Shim Insulator
14	1700429	Flat Washer - 3/8"
15	1700434	Lock Washer - 3/8"
16	1700407	Hex Nut - 3/8"
17	1123557	Locking Pin
18	1704276	Protective Cap - 1/4" x 1/2"
19	1123554	Locking Pin Bracket
20	1705231	Carriage Bolt - 5/16" x 3/4" - GR5
21	1704904	Extension Spring - 7/32" x .023" x 1-15/16"
22	1700411	Hex Nut - 15/16"
23	1700433	Lock Washer - 15/16"
24	1123553	Motor Mount Bracket
25	1123895	Intermediate Bracket - Rail Mount
26	1701061	Hex Head Cap Screw - 3/8" x 1"
27	1702891	Hex Head Cap Screw - 3/8" x 1-1/4"
28	1120291	Spacer Washer - 1/4" x 1 OD" x .406"
29	1124591	AutoTrap™/MaxxTrap™ Motor
30	1705230	Hex Head Cap Screw - 5/16" x 4"
31	1124858	Universal Debris Deflector
32	1704716	SMARTwire™ - 6 Ga. x Plug x 1/4" Terminal - 10'
33	1701045	Hex Head Cap Screw - 5/16" x 3/4"
34	1124846	Universal Modular Control Bracket
35	1705258	Button Plug - 11/16"
36	1704721	Rubber Grommet w/Slot - .094" x 7/8"
37	1705115	Push-In Rubber Grommet - 3/8" x 11/16"
38	1700436	Lock Washer - 1/4"
39	1703959	Hex Head Cap Screw - 1/4" x 3/4"
40	1705480	Motor Bushing - 4"
41	1705476	Soc Head Cap Screw - 3/8" x 1/2"
42	1123568	Crank Handle
43	1703231	Cable Tie - 8"
44	1704312	Motor-Reversing Solenoid
45	1704308	Flange Cap Screw - #10 x 1/2"
46	1704309	Solenoid Cover Gasket
47	1126875	SMART3™ Solenoid Cover w/Gasket
	1123775	SMART2™ Solenoid Cover w/Gasket
48	1705479	Allen Wrench - 5/16" x 6"
49	1705088	Motor Bushing* - 4-7/16"
50	1705083	Hex Head Cap Screw* - 5/16" x 2" - GR8
51	1123562	Modular Control Bracket*
52	1123563	Debris Deflector*
53	1129829	AutoTrap™ Motor*

*Order these components if AutoTrap™ was purchased before 2016.

MAXXTRAP™ – CRANK ARMS/CRANK RETAINERS

ITEM	PART #	DESCRIPTION
	1101929	Offset Crank Retainer Kit [Includes 6; 9; 10; 2 of 5, 7 & 8]
	1107062	Offset Crank Retainer Hardware Kit [Includes 6; 10; 2 of 5, 7 & 8]
	1122729	Override Crank [Includes 1; 2; 3]
1	1700527	Econo U-Joint
2	1700445	Spring Pin - 1/4" x 1-1/2"
3	1124947	Crank Arm - 42"
4	1116110	Crank Handle Kit (Handle - Washer - Nut)
5	1700407	Hex Nut - 3/8"
6	1100574	Cable w/#5 Interlock Snap
7	1700400	Self-tapping Screw - Non Corrosive Coating - 3/8" x 1"
8	1700434	Lock Washer - 3/8"
9	1101930	Offset J-Hook Crank Retainer
10	1700526	Wire Lock Pin - 3/8" x 2-1/2"

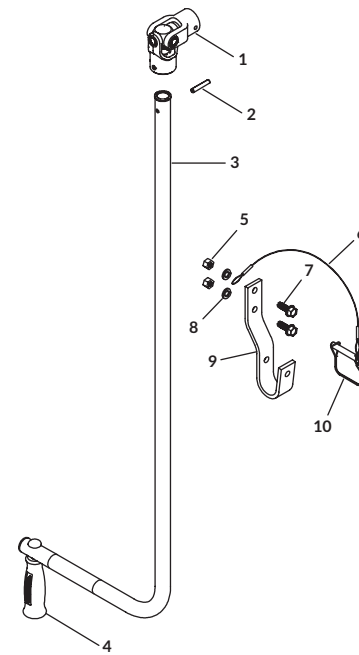

MAXXTRAP™ – SMARTWIRE™ HOPPER DOOR OPENERS

ITEM	PART #	DESCRIPTION
1	1705083	Hex Head Cap Screw - 5/16" x 2" - GRB
2	1701434	Hex Head Cap Screw - 3/8" x 1-1/2"
3	1705078	Override Adapter - 1"
	1705077	Override Adapter - 7/8"
4	1124587	Override Coupling
5	1701176	Flat Washer - 3/8" - SAE
6	1705089	Manual Override Pawl
7	1704297	Nylon Lock Nut - 5/16"
8	1124583	Manual Override Bracket - Wilson RP2
	1124618	Manual Override Bracket - Wilson G2
9	1705087	Stainless Wave Washer - 3/8"
10	1701580	Nylon Lock Nut - 3/8"
11	1703231	Cable Tie - 8"
12	1704716	SMARTwire™ - 6 Ga. x Plug x 1/4" Terminal - 10'
13	1705257	Cable Assembly - 7'
14	1704308	Flange Cap Screw - #10 x 1/2"
15	1122717	Dummy Solenoid Cover
16	1704309	Solenoid Cover Gasket
17	1705408	Motor-Reversing Solenoid
18	1703959	Hex Head Cap Screw - 1/4" x 3/4"
19	1700436	Lock Washer - 1/4"
20	1124846	Universal Modular Control Bracket
21	1705101	Rubber Grommet - 3/8" x 1/2"
22	1704721	Rubber Grommet w/Slot - .094" x 7/8"
23	1124591	AutoTrap™/MaxxTrap™ Motor
24	1705480	Motor Bushing - 4"
25	1122795	Gearbox Bracket - GEN2*
	1123460	Gearbox Bracket - STO*
	1124449	Gearbox Bracket*
	1124564	Gearbox Bracket - Wilson*
	1124628	Gearbox Bracket - Original RRP*
	1125618	Gearbox Bracket - MRT*
26	1124566	Gearbox Shim Insulator
27	1122553	SMART2™ Control Module - MaxxTrap™
28	1122655	Mud Guard
29	1124321	Modular Control Bracket
30	1122750	SMART2™ Control Module w/Mounting Bracket
31	1705412	Flange Cap Screw - #10 x 1-1/2"
32	1701045	Hex Head Cap Screw - 5/16" x 3/4"
33	1124858	Universal Debris Deflector
34	1700789	Protective Cap - 1.3" ID
35	1705476	Soc Head Cap Screw - 3/8" x 1/2"
36	1700433	Lock Washer - 5/16"
37	1705477	O-Ring - 7/8" ID x 1-1/8" OD
38	1705463	Drive Shaft - 5-3/4"
39	1705142	Hex Head Cap Screw - 3/8" x 1"
40	1700427	Flat Washer - 1/4"

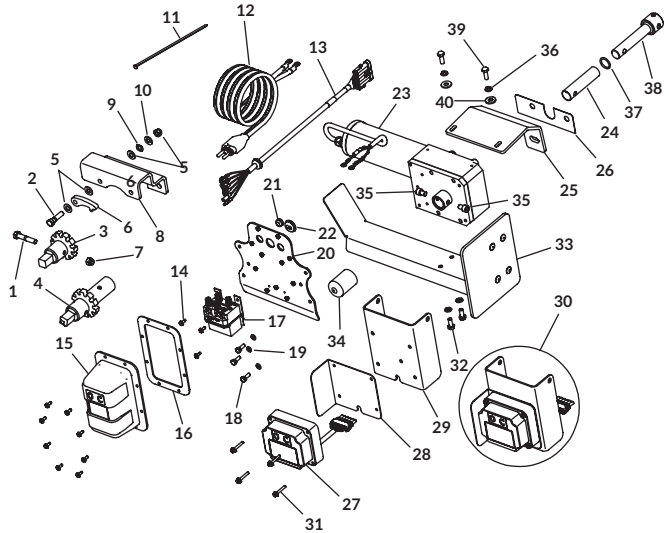

*Call w/year, make and model to determine correct bracket for your system.

NOTE: These are replacement parts for MaxxTraps purchased after 2016. For replacement parts for systems before 2016, please CALL. Be sure to have the year, make and model of your trailer ready.

PROTRAP® – RAIL MOUNT ASSEMBLIES

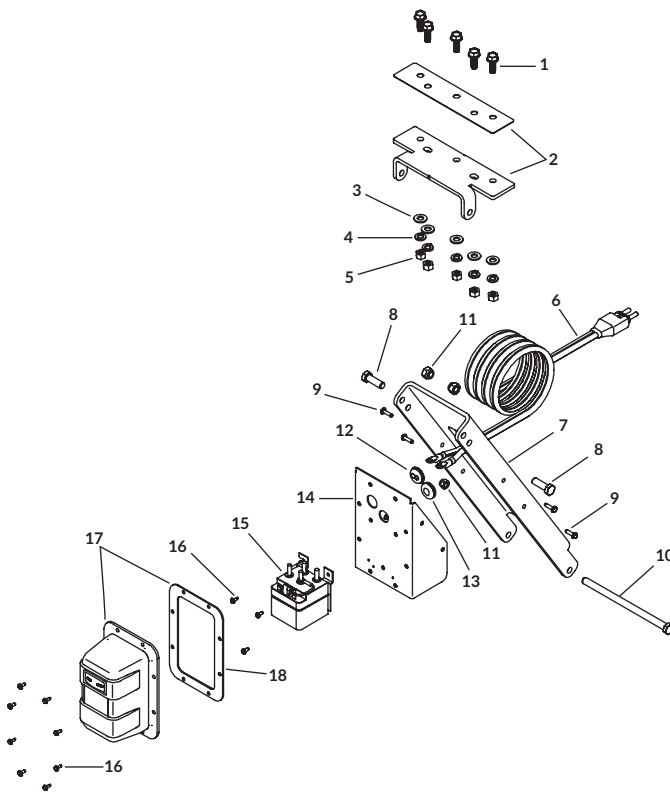

ITEM	PART #	DESCRIPTION
	1118569	Hinge Bracket Hardware* - Rail Mount [Includes 10; 2 of 8; 5 of 1, 3, 4, 5 & 11]
1	1700400	Self-Tapping Screw - Non Corrosive Coating - 3/8" x 1"
2	1119074	Replacement Hinge Bracket - Rail Mount
3	1700429	Flat Washer - 3/8"
4	1700434	Lock Washer - 3/8"
5	1700407	Hex Nut - 3/8"
6	1704716	SMARTwire™ - 6 Ga. x Plug x 1/4" Terminal - 10'
7	1118527	Intermediate Bracket - Rail Mount
8	1702904	Hex Head Cap Screw - 3/8" x 1-1/8"
9	1704367	Hex Flange Cap Screw - #10 x 3/4"
10	1703178	Hex Head Cap Screw - 3/8" x 6-1/2"
11	1701580	Nylon Lock Nut - 3/8"
12	1704721	Rubber Grommet w/Slot - .094" x 7/8"
13	1704818	Rubber Grommet - 1/2" x 1-1/16"
14	1120701	Modular Control Bracket
15	1704312	Motor-Reversing Solenoid
16	1704308	Flange Cap Screw - #10 x 1/2"
17	1126874	SMART3™ Solenoid Cover w/Gasket
	1123082	SMART2™ Solenoid Cover w/Gasket
18	1704309	Solenoid Cover Gasket
	1704378	Dielectric Connector Protector (not shown)

*Includes dielectric connector protector.

PROTRAP® – SMARTWIRE™ HOPPER DOOR OPENERS

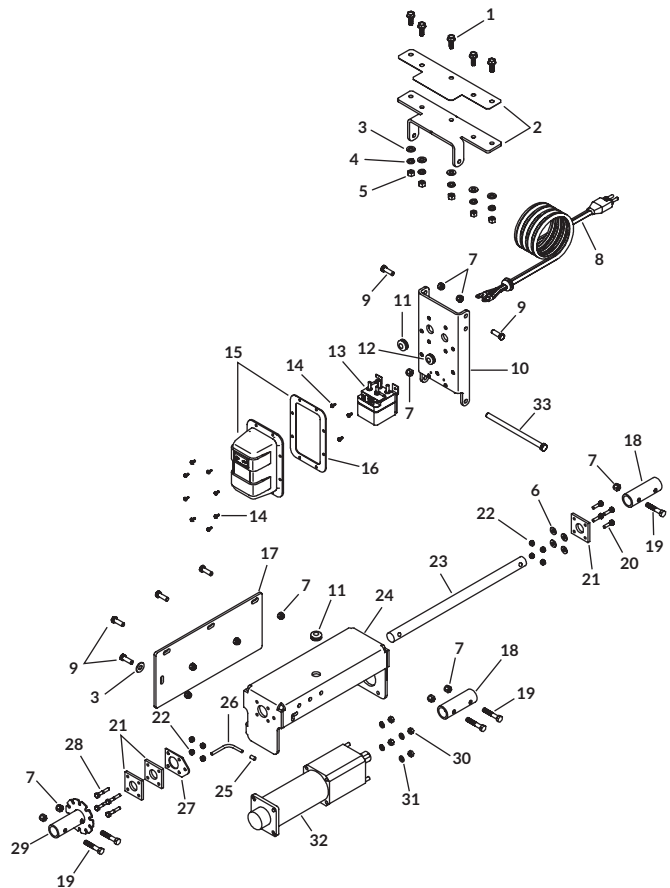

ITEM	PART #	DESCRIPTION
	1118253	Hinge Bracket Hardware Kit* [Includes 2 of 9 & 19; 4 of 7; 5 of 1, 3, 4 & 5]
1	1700400	Self-Tapping Screw - Non Corrosive Coating - 3/8" x 1"
2	1118439	Replacement Hinge Bracket
3	1700429	Flat Washer - 3/8"
4	1700434	Lock Washer - 3/8"
5	1700407	Hex Nut - 3/8"
6	1700427	Flat Washer - 1/4"
7	1701580	Nylon Lock Nut - 3/8"
8	1704716	SMARTwire™ - 6 Ga. x Plug x 1/4" Terminal - 10'
9	1702904	Hex Head Cap Screw - 3/8" x 1-1/8"
10	1120623	Intermediate Bracket - SMARTwire™
11	1704270	Rubber Grommet - 1/2" x 11/16"
12	1704722	Rubber Grommet w/Slot - 1/4" x 7/8"
13	1704312	Motor-Reversing Solenoid
14	1704367	Hex Flange Cap Screw - #10 x 3/4"
15	1126874	SMART3™ Solenoid Cover w/Gasket
	1123082	SMART2™ Solenoid Cover w/Gasket
16	1704309	Solenoid Cover Gasket
17	1118436	Rock Flap [Includes Flap; 4 of 3, 7 & 9]
18	1118038	Coupling - 1-3/8" x 4"
19	1704264	Hex Head Cap Screw - 3/8" x 2"
20	1700381	Hex Head Cap Screw - 1/4" x 1"
21	1118034	Flange Bearing
22	1701543	Nylon Lock Hex Nut - 1/4"
23	1118033	Manual Shaft
24	1118026	Motor Mount Bracket - Driver Side
	1119141	Motor Mount Bracket - Passenger Side
25	1704276	Protective Cap - 1/4" x 1/2"
26	1118036	Locking Pin
27	1118035	Lock Retainer
28	1700377	Hex Head Cap Screw - 1/4" x 1-1/2"
29	1118031	Locking Coupling
30	1704389	Hex Nut - 5/16"
31	1700433	Lock Washer - 5/16"
32	1119072	ProTrap® 150 Motor
	1118400	ProTrap® 250 Motor
	1125713	ProTrap® 350 Motor
33	1703178	Hex Head Cap Screw - 3/8" x 6-1/2"
	1704378	Dielectric Connector Protector (not shown)

*Includes dielectric connector protector.

AUTOTRAP™/MAXXTRAP™/PROTRAP® – CAB WIRING KITS

ITEM	PART #	DESCRIPTION
		Cab Wiring Kit* - 6 Ga. - Master Disconnect - 30'
1118417		[Includes 2; 3; 4; 9; 10; 13; 2 of 5, 6, 8 & 11; 4 of 1 & 12; 15 of 7]
		Cab Wiring Kit - 6 Ga. - Master Disconnect w/External Switch - 30' [Includes 4; 9; 10; 13; 14; 2 of 11; 4 of 12; 15 of 7]
1125292		[Includes 4; 9; 10; 13; 14; 2 of 11; 4 of 12; 15 of 7]
		Cab Wiring Kit* - 4 Ga.** - Master Disconnect - 30'
1122725		[Includes 2; 3; 4; 9; 10; 13; 2 of 5, 6, 8 & 11; 4 of 1 & 12; 15 of 7]
		Cab Wiring Kit - 4 Ga.** - Master Disconnect w/External Switch - 30' [Includes 4; 9; 10; 13; 14; 2 of 11; 4 of 12; 15 of 7]
1125293		[Includes 4; 9; 10; 13; 14; 2 of 11; 4 of 12; 15 of 7]
1125617		Master Disconnect Switch Kit [Includes 2; 3; 2 of 5, 6 & 8; 4 of 1]
1120466		Master Disconnect Kit* - 10' [Includes 2; 3; 4; 9; 10; 2 of 5, 6, 8 & 11; 4 of 1 & 12; 15 of 7]
1120467		Master Disconnect Kit* - 30' [Includes 2; 3; 4; 9; 10; 2 of 5, 6, 8 & 11; 4 of 1 & 12; 15 of 7]
1118325		Mounting Bracket Hardware Kit [Includes 2 of 5, 6 & 8; 4 of 1]
1118254		Cab Wiring Hardware Kit - 6 Ga. [Includes 4; 9; 2 of 11; 4 of 12; 15 of 7]
1122761		Cab Wiring Hardware Kit - 4 Ga.** [Includes 4; 9; 2 of 11; 4 of 12; 15 of 7]
1	1700398	Self-Drilling Screw - 1/4" x 3/4"
2	1118323	Disconnect Switch Mounting Bracket
3	1704283	Battery Disconnect Rotary Switch
4	1704284	Face Plate
5	1704152	Dome Nut - 1/2"
6	1704187	Lock Nut - 1/2"
7	1703231	Cable Tie - 8"
8	1704330	Rubber Insulating Boot
9	1704354	40-Amp Modified-Reset Circuit Breaker
10	1119077	Dual-Conductor Wire - 6 Ga. - 10'
	1119078	Dual-Conductor Wire - 6 Ga. - 20'
	1118495	Dual-Conductor Wire - 6 Ga. - 30'
	1119645	Dual-Conductor Wire - 6 Ga. - 40'
	1110312	Dual-Conductor Wire - 6 Ga. - 50'
	1127835	Dual-Conductor Wire - 6 Ga. - 60'
	1108102	Dual-Conductor Wire - 6 Ga. - 75'
	1108101	Dual-Conductor Wire - 6 Ga. - 100'
	1704888	SMARTwire™ - 4 Ga. - Plug/Socket - 25'
	1705108	SMARTwire™ - 4 Ga. - Plug/Socket - 30'
	1123042	SMARTwire™ - 4 Ga. - Socket - 40'
	1704989	SMARTwire™ - 4 Ga. - Socket - 90'
	1703822	Dual-Conductor Wire - 6 Ga. - 259 Strand (per foot)
	1705107	Dual-Conductor Wire - 4 Ga. - 133 Strand (per foot)
11	1703245	Ring Terminal - 6 Ga. x #10 Stud - Motor/Breaker
	1705106	Ring Terminal - 4 Ga.** x #10 Stud - Motor/Breaker
12	1703244	Ring Terminal - 6 Ga. x 3/8" Stud - Battery
	1705105	Ring Terminal - 4 Ga.** x 3/8" Stud - Battery
13	1115385	Heavy-Duty Dual-Conductor Plug
14	1125214	External Master Disconnect Switch
15	1125291	External Master Disconnect Switch Kit
	1704378	Dielectric Connector Protector (not shown)

*Includes dielectric connector protector.

**AutoTrap™ and MaxxTrap™ use 4-gauge wire.

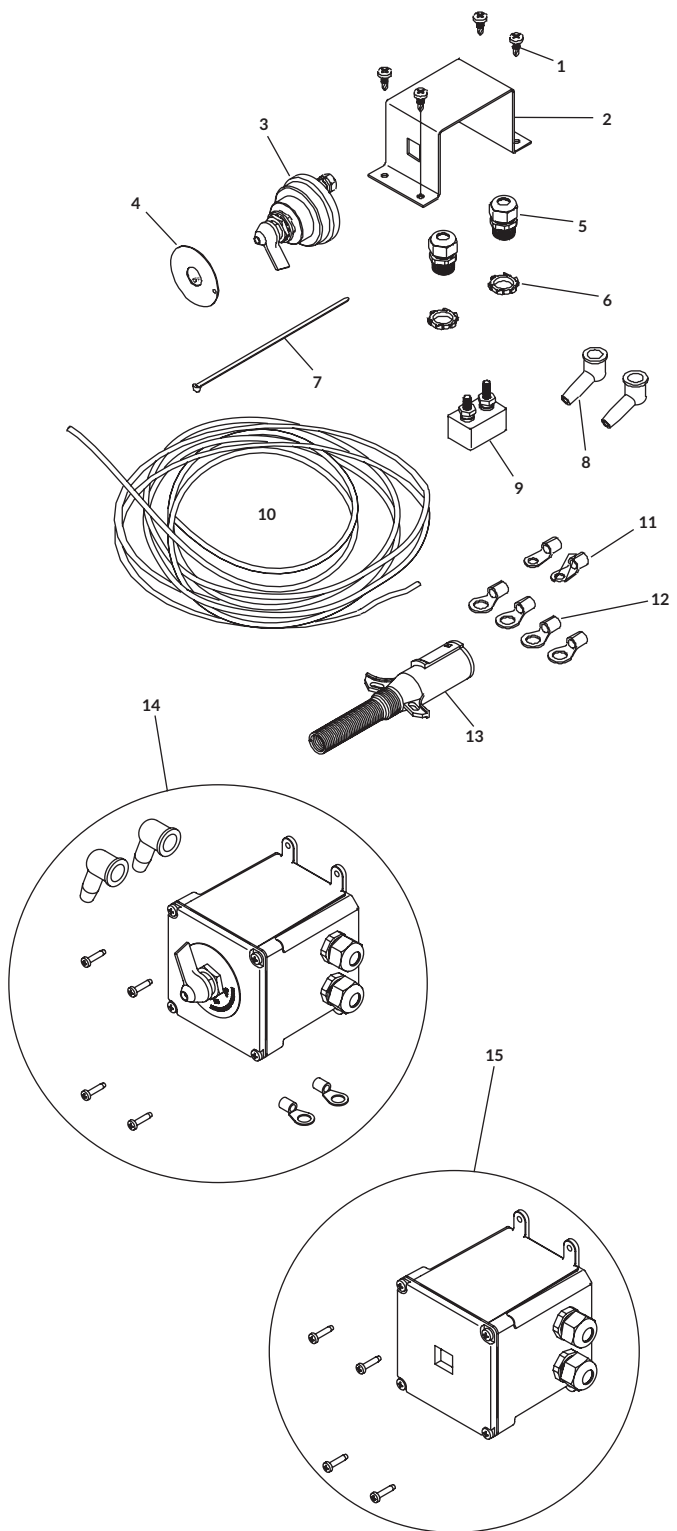

AUTOTRAP™/MAXXTRAP™/PROTRAP® – SMARTWIRE™ ELECTRICAL

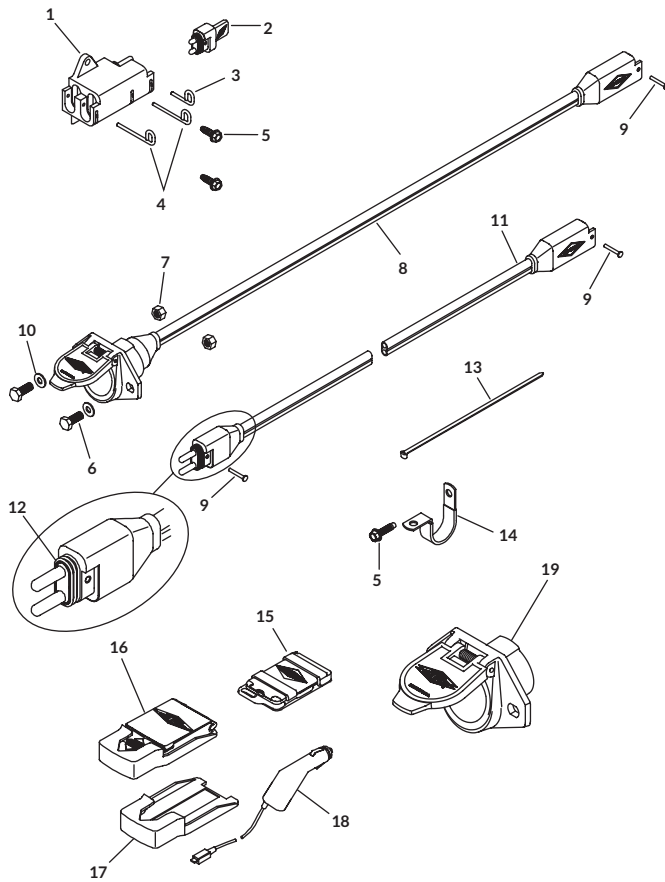

ITEM	PART #	DESCRIPTION
SMARTwire™ COMPONENTS		
	1120849	Junction Block Kit w/Harness Plug [Includes 1; 2; 3; 2 of 4 & 5]
	1120848	Junction Block Kit w/o Harness Plug [Includes 1; 3; 2 of 4 & 5]
	1125580	SMARTwire™ Dual-Conductor Socket w/Hardware [Includes 8; 9; 2 of 6, 7 & 10]
	1120851	Wiring Retaining Hardware w/Locking Pin* [Includes 9; 4 of 5 & 14]
	1120906	Wiring Retaining Hardware* [Includes 4 of 5 & 14]
1	1704695	Harness Junction Block
2	1704717	Wire Harness Rubber Plug
3	1704711	Harness Lock Pin - Short
4	1704696	Harness Lock Pin - Long
5	1704338	Self-Tapping Screw - 1/4" x 1"
6	1701045	Hex Head Cap Screw - 5/16" x 3/4"
7	1704946	Top Lock Flange Nut - 5/16"
8	1120670	SMARTwire™ Dual-Conductor Socket - 6 Ga. x 3'6"
	1126944	SMARTwire™ Dual-Conductor Socket - 4 Ga. x 3'6"
9	1704751	Harness Lock Pin - 1/4" x 7/8"
10	1700427	Flat Washer - 1/4"
11	1704874	SMARTwire™ - 6 Ga. - Plug/Socket - 8'
	1704827	SMARTwire™ - 6 Ga. - Plug/Socket - 16'
	1704704	SMARTwire™ - 6 Ga. - Plug/Socket - 25'
	1704888	SMARTwire™ - 4 Ga.** - Plug/Socket - 25'
	1705108	SMARTwire™ - 4 Ga.** - Plug/Socket - 30'
12	1704720	Wire Harness Seal
13	1703231	Cable Tie - 8"
14	1702108	Wire Clip - 3/4" ID
	1704378	Dielectric Connector Protector (not shown)
REMOTES		
15	1126867	SMART3™ Remote - Grain Trailer
	1704569	Caribiner Key Strap (not shown)
	1122108	SMART2™ Remote w/Cradle/Charging Cable [Includes 16; 17; 18]
16	1122231	SMART2™ Remote w/Cradle
17	1124305	SMART2™ Remote Cradle
18	1704958	SMART2™ Charging Cable
19	1704978	Dual Conductor Housing - Female

*Includes dielectric connector protector.

**AutoTrap™ and MaxxTrap™ use 4-gauge SMARTwire™.

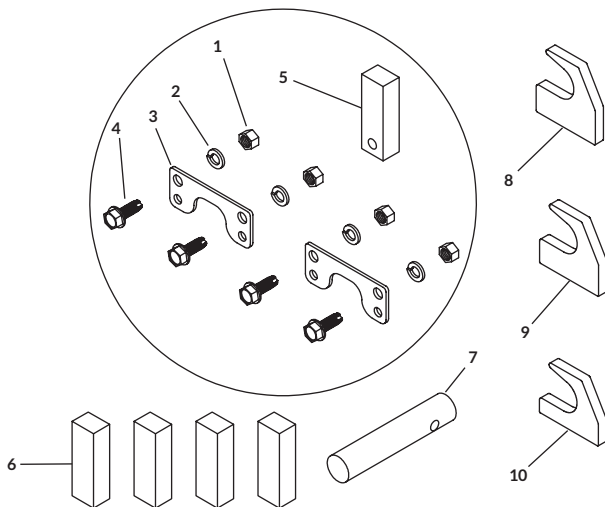

AUTOTRAP™/PROTRAP® – TRAILER MOUNTS

ITEM	PART #	DESCRIPTION
FOR DAKOTA TRAILERS		
	1118337	Hopper Parts Kit* [Includes 5; 2 of 3; 4 of 1, 2 & 4]
1	1700407	Hex Nut - 3/8"
2	1700434	Lock Washer - 3/8"
3	1118305	Bearing Retainer
4	1700400	Self-Tapping Screw - Non Corrosive Coating - 3/8" x 1"
5	1118306	Door Stop - 3" x 1"
FOR TIMPTE TRAILERS		
	1118338	Hopper Parts Kit* [Includes 4 of 6]
6	1118307	Door Stop - 3" x 1"
FOR CORNHUSKER TRAILERS		
	1118339	Hopper Parts Kit* [Includes 7]
7	1118308	Adapter Shaft
FOR NEVILLE TRAILERS		
	1118872	Hopper Parts Kit* [Includes 4 of 8]
8	1120472	Stop Hook - 1"
HIGH HOOKS		
	1118870	Hopper Parts Kit* - High [Includes 4 of 9]
9	1118585	Stop Hook - 1-1/8"
HIGH & LOW HOOKS		
	1118871	Hopper Parts Kit* - High & Low [Includes 4 of 9 & 10]
10	1118745	Stop Hook - 5/8"

*Includes instructions.

DRIVEMAXX™

ITEM	PART #	DESCRIPTION
	1128470	DriveMaxx™ Main Beam Assembly [Includes 10; 16; 17; 18; 24; 2 of 11, 12 & 22; 4 of 19, 21 & 25; 8 of 23; 10 of 20]
	1127234	Wheel Assembly - Clockwise [Includes 2; 3; 5; 4 of 1 & 12]
	1127230	Wheel Assembly - Counterclockwise [Includes 2; 4; 5; 4 of 1 & 12]
	1127278	Assembly Hardware - DriveMaxx™ [Includes 2 of 11, 13; 14; 15; 10 of 16]
1	1705967	Hex Head Cap Screw - 1/2" x 1"
2	1127231	Wheel Hub
3	1705966	Wheel - Clockwise
4	1705965	Wheel - Counterclockwise
5	1705968	Lynch Pin - 5/16" x 1-3/4" - Zinc
6	1128578	Jack - Dual
7	1127235	Jack - Single
8	1705911	Flat Washer - 1/2"
9	1705920	Cap Screw - 1/2" x 1-1/2"
10	1128469	DriveMaxx™ Main Beam Weldment
11	1705914	Hex Head Cap Screw - 1/2" x 3-1/4"
12	1705913	Nylon Lock Nut - 1/2"
13	1127213	Jack Mount Rack
14	1705910	Cap Screw - 3/8" x 1-1/2"
15	1705921	Flat Washer - 3/8" - USS
16	1705918	Nylon Lock Nut - 3/8"
17	1124591	AutoTrap™/MaxxTrap™ Motor
18	1703231	Cable Tie - 8"
19	1125875	SMARTwire™ - 6 Ga. - Plug x 1/4" Terminal - 1'
20	1127260	Junction Box 2 x 4 x 4
21	1704152	Dome Nut - 1/2"
22	1705957	Flange Cap Screw - #10 x 3/4"
23	1704187	Lock Nut - 1/2"
24	1700381	Hex Head Cap Screw - 1/4" x 1"
25	1704548	Flat Washer - #12
26	1119364	Junction Box Back Plate
27	1700408	Hex Nut - 1/4"
28	1127464	Drive Brace - 10" to 11"
	1127468	Drive Brace - 11" to 12"
	1127229	Drive Brace - 12" to 13"
	1127424	Drive Brace - 13" to 14"
	1127273	Drive Brace - 14" to 15"
	1127425	Drive Brace - 15" to 16"
	1127274	Drive Brace - 16" to 17"
	1127426	Drive Brace - 17" to 18"
	1127275	Drive Brace - 18" to 19"
	1128621	Drive Brace - 19" to 20"
	1128622	Drive Brace - 20" to 21"
29	1127291	Tube Band w/ Jack Mount - 8"
	1127250	Tube Band w/ Jack Mount - 10"
	1127252	Tube Band w/ Jack Mount - 12"
	1127293	Tube Band w/ Jack Mount - 13"
	1127254	Tube Band w/ Jack Mount - 14"
30	1127282	Tube Band - 8"
	1127246	Tube Band - 10"
	1127247	Tube Band - 12"
	1127283	Tube Band - 13"
	1127248	Tube Band - 14"

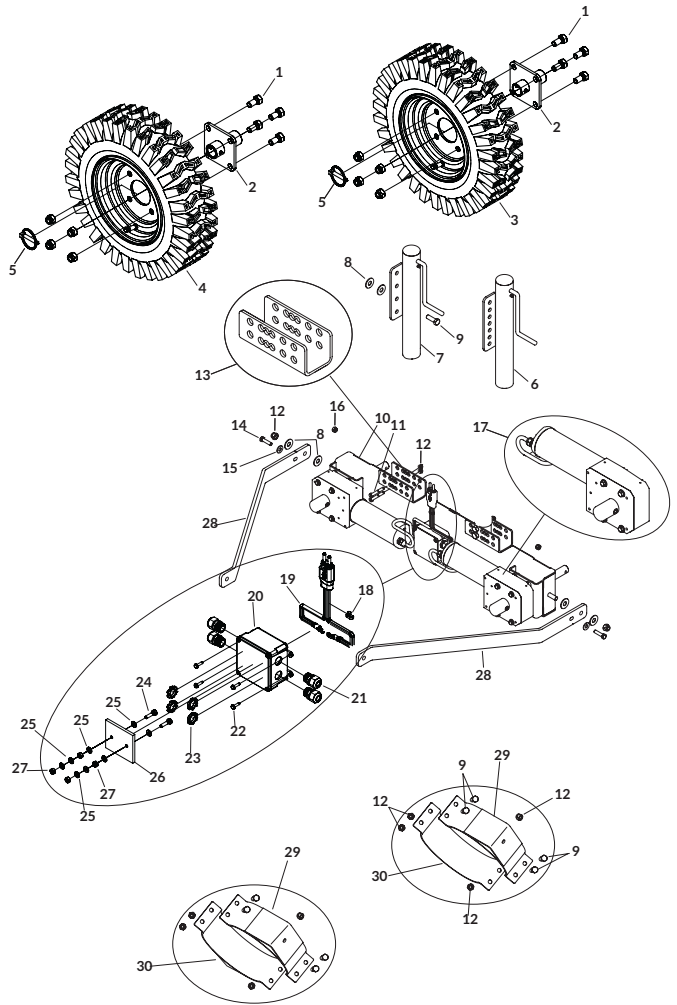

DRIVEMAXX™ - ELECTRICS

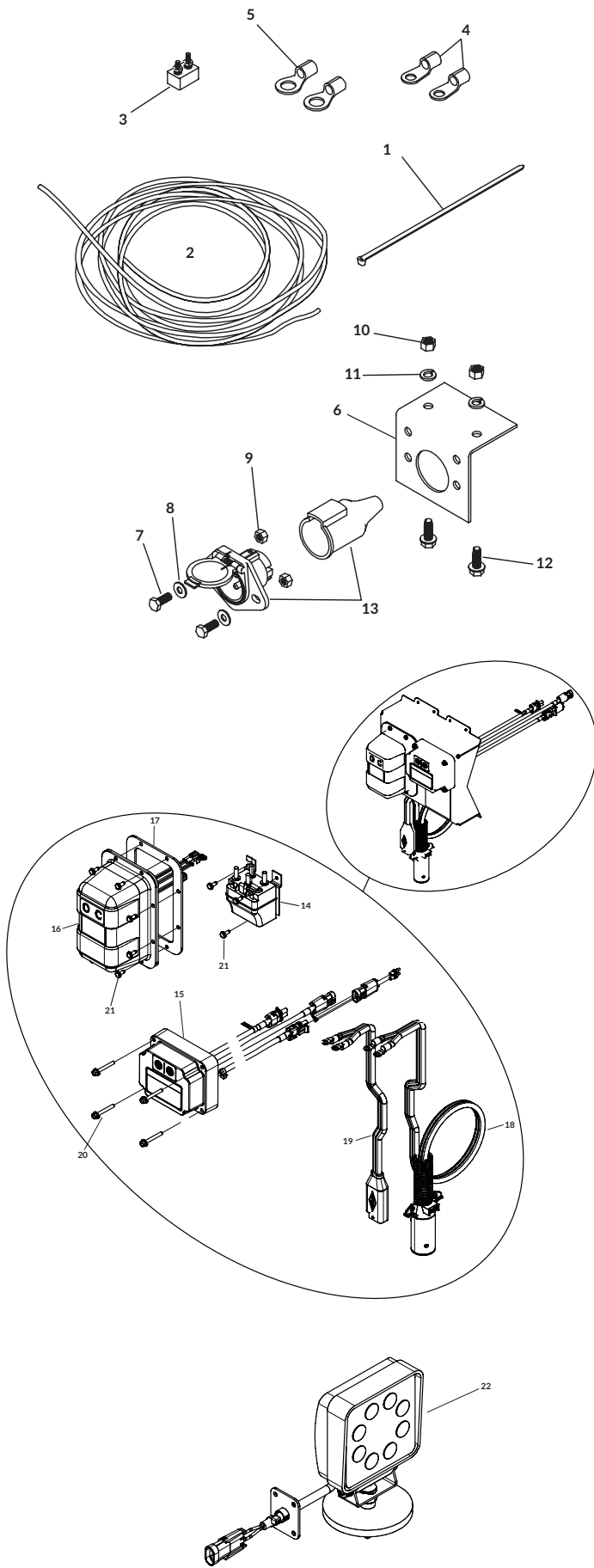

ITEM	PART #	DESCRIPTION
	1120823	Tractor Wiring Kit - 40 Amp - Wireless - 30'
	1128575	LiteALL™ Control Assembly - SMART3
	1126881	SMART3™ Solenoid Cover w/Gasket
	1120855	Breaker Hardware
1	1703231	Cable Tie - 8"
2	1118495	Dual-Conductor Wire - 6 Ga. - 30'
3	1704354	40-Amp Modified-Reset Circuit Breaker
4	1703245	Ring Terminal - 6 Ga. x #10 Stud - Motor/Breaker
5	1703244	Ring Terminal - 6 Ga. x 3/8" Stud - Battery
6	1109015	Conductor Plug Mounting Bracket
7	1701045	Hex Head Cap Screw - 5/16" x 3/4"
8	1700427	Flat Washer - 1/4"
9	1704946	Top Lock Flange Nut - 5/16"
10	1700407	Hex Nut - 3/8"
11	1700434	Lock Washer - 3/8"
12	1700400	Self-Tapping Screw - 3/8" x 1" (non-corrosive coating)
13	1119557	Heavy-Duty Dual-Conductor Socket w/Boot - Vertical Pin
14	1704312	Motor-Reversing Solenoid
15	1126893	SMART3™ Control Module - Latching - On/Off w/o Safety Lockout
16	1126886	SMART3™ Solenoid Cover - Non Express
17	1704309	Solenoid Cover Gasket
18	1128684	Dual Conductor 6GA Wire Assembly - 16'
19	1120817	SMARTwire™ - 6 Ga. - Socket x 1/4" Terminal - 6'3"
20	1705412	Flange Cap Screw - #10 x 1-1/2"
21	1704308	Flange Cap Screw - #10 x 1/2"
22	1128572	Magnetic LED LiteALL™

ELECTRIC GATE/ELECTRIC HOIST

ITEM	PART #	DESCRIPTION
	1124614	Air Fitting Hardware [Includes 4 of 35 & 36]
		Gate/Hoist Hardware [Includes 5; 7; 9;
	1124615	2 of 6; 4 of 13, 27 & 33; 8 of 1, 3, 4, 10, 11, 14 & 17;
		10 of 26 & 27; 40 of 31]
	1123212	Wire Retaining Hardware [Includes 10 of 26 & 27]
1	1705475	Elevator Bolt - 3/8" x 1"
2	1124588	Actuator Mounting Bracket
3	1700434	Lock Washer - 3/8"
4	1700407	Hex Nut - 3/8"
5	1700369	Hex Head Cap Screw - 3/8" x 1-3/4"
6	1701176	Flat Washer - 3/8" - SAE
7	1701580	Nylon Lock Nut - 3/8"
8	1128354	Gate Actuator - 12 Stroke w/2-Post WeatherPack™
9	1704427	Wire Lock Pin - 3/8" x 1-3/4"
10	1700408	Hex Nut - 1/4"
11	1700436	Lock Washer - 1/4"
12	1124231	Control Module Mounting Bracket*
13	1700381	Hex Head Cap Screw - 1/4" x 1"
14	1702653	Machine Screw Nut
15	1124669	SMART2™ Control Module - Momentary - Open/Closed
	1126890	SMART3™ Control Module - Momentary - Open/Closed
16	1125225	SMART2™ Control Module - Momentary - Up/Down
	1126894	SMART3™ Control Module - Momentary - Up/Down
17	1705412	Flange Cap Screw - #10 x 1-1/2"
18	1705491	Ring Terminal - 10-12 Ga. x 3/8" Stud
19	1704173	Ring Terminal - 10-12 Ga. x #10 Stud
20	1124613	Power Wire w/Circuit Breaker
21	1705513	6-Amp Modified-Reset Circuit Breaker
22	1122705	Output Splitter w/WeatherPak™
23	1124454	Power Cable
24	1124455	Hoist Control Cable
25	1122704	Extension Cable w/WeatherPak™ - 20'
26	1702108	Wire Clip - 3/4" ID
27	1704338	Self-Tapping Screw - 1/4" x 1"
	1700398	Self-Drilling Screw - 1/4" x 3/4"
28	1704958	SMART2™ Charging Cable
29	1124305	SMART2™ Remote Cradle
30	1122231	SMART2™ Remote w/Cradle
	1122108	SMART2™ Remote w/Cradle/Charging Cable [Includes 28; 30]
31	1703231	Cable Tie - 8"
32	1705466	Air Brake Tube - 1/4"
33	1704343	Hex Head Cap Screw - 1/4" x 1-1/2"
34	1124867	Solenoid Air Valve - 3 Way
35	1705516	Air Fitting - Union Tee - 1/4"
36	1705515	Air Fitting - 90° Male Elbow - 1/4"
37	1126867	SMART3™ Remote
38	1125081	Receiver Bracket - Mini Module - Farm
	1704569	Carabiner Key Strap (not shown)

*Optional; if ordered, use with items 10, 11 and 13.

NOTE: If item 8 (P/N 1128354) is purchased to be used with a non-Shur-Co® product, then item 21 (P/N 1705513) MUST also be purchased or warranty for gate actuator is void.

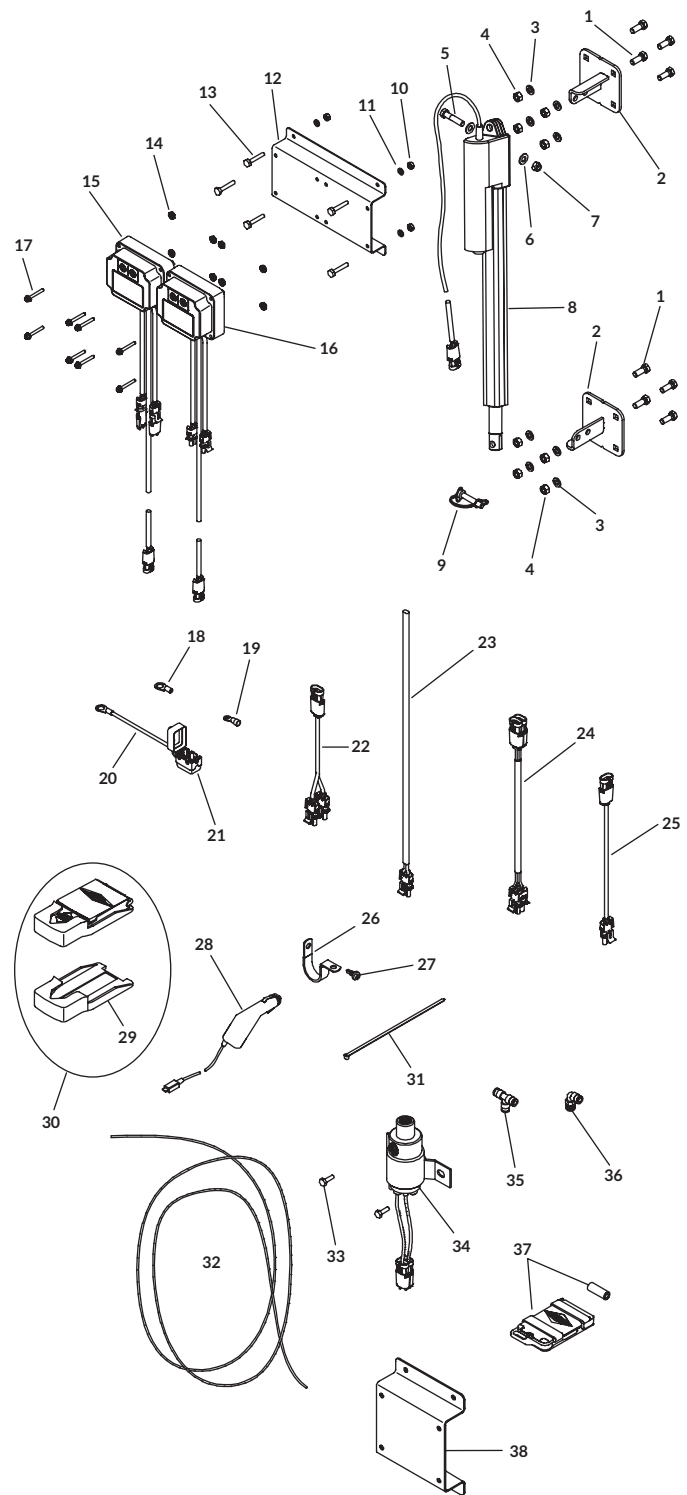

AUTOGATE™

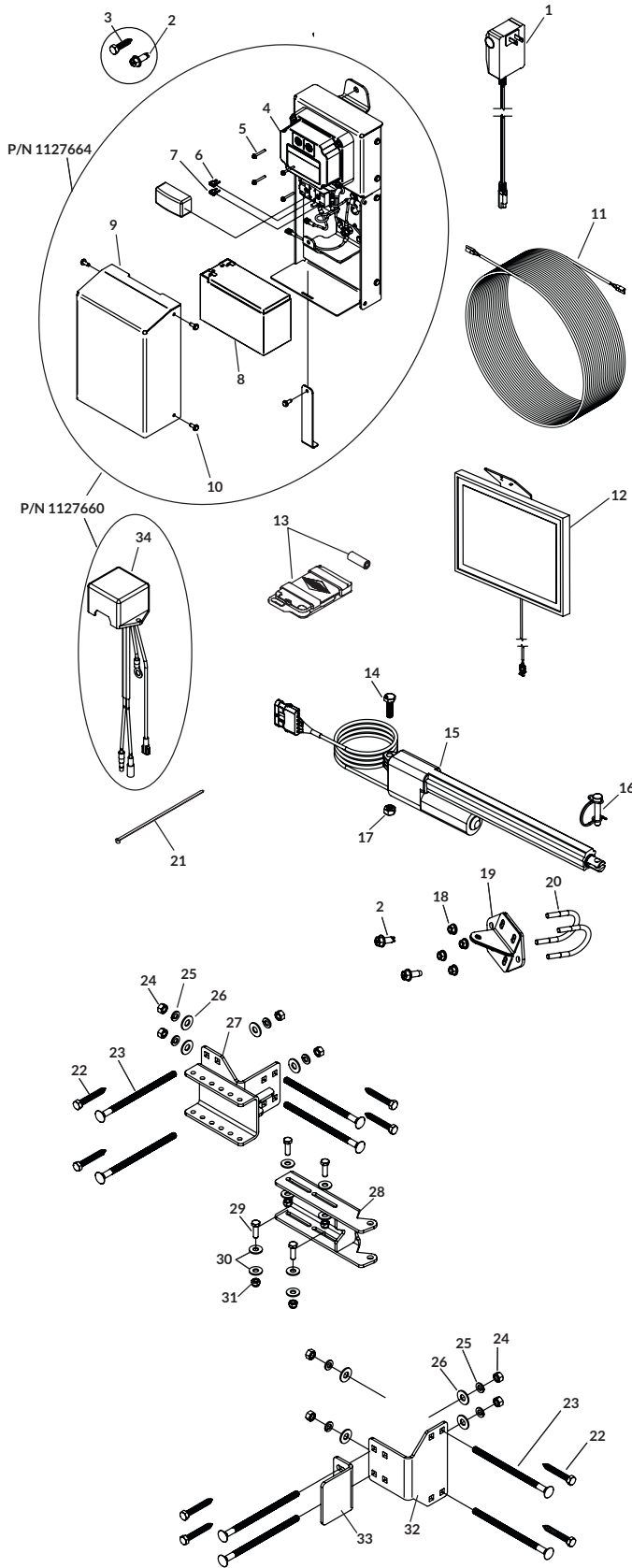

ITEM	PART #	DESCRIPTION
	1127664	Control Box - Trickle Charge [Includes 4; 6; 7; 8; 9; 4 of 5; 25 of 10]
	1127660	Control Box - Solar [Includes 4; 6; 7; 8; 9; 34; 4 of 5; 25 of 10]
	1128035	Gate Stop Hardware [Includes 32; 33; 4 of 22, 23, 24, 25 & 26]
	1128036	Hinge Post Bracket Hardware [Includes 4 of 22, 23, 24, 25, 26, 29 & 31; 8 of 30]
	1128037	U-Clamp Bracket Hardware [Includes 14; 16; 17; 19; 2 of 2; 4 of 18; 6 of 20]
	1128038	Solar Panel Mounting Hardware [Includes 4 of 2 & 22; 30 of 21]
	1128039	Control Box Mounting Hardware [Includes 2 of 2 & 3]
	1128387	Box Hardware - Trickle Charge Includes 14; 16; 17; 19; 27, 28, 32; 33; 2 of 3; 4 of 18, 29 & 31; 6 of 2 & 20; 8 of 22, 23, 24, 25, 26 & 30]
	1127913	Box Hardware - Solar [Includes 14; 16; 17; 19; 27, 28, 32; 33; 2 of 3; 4 of 18, 29 & 31; 6 of 20; 8 of 2, 23, 24, 25, 26 & 30; 12 of 22; 30 of 21]
1	1128511	12 Volt Trickle Charger
2	1700400	Self-Tapping Screw - 3/8" x 1" (non-corrosive coating)
3	1706065	Lag Screw - 3/8" x 1-1/2"
4	1127656	SMART3™ Control Module - Trickle Charger
5	1705412	Flange Cap Screw - #10 x 1-1/2"
6	1705154	Mini Fuse - 10 Amp
7	1706024	Mini Fuse - 15 Amp
8	1706022	12 Volt Rechargeable Battery
9	1127995	Battery Cover
10	1704308	Flange Cap Screw - #10 x 1/2"
11	1128480	Extension Cable - 100'
12	1127657	Solar Panel Assembly
13	1126867	SMART3™ Remote - Grain Trailer
14	1706072	Cap Screw - M10 x 35mm
15	1127655	Gate Actuator - 12 Stroke w/5-Post WeatherPack™
16	1704427	Wire Lock Pin - 3/8" x 1-3/4"
17	1705361	Hex Nut - M10
18	1704931	Flanged Nylon Lock Nut - 5/16"
19	1127898	Gate Bracket
20	1706068	U-Bolt - 5/16" x 1-1/2" ID
	1706070	U-Bolt - 5/16" x 1-3/4" ID
	1706071	U-Bolt - 5/16" x 2" ID
21	1703231	Cable Tie - 8"
22	1706066	Lag Screw - 3/8" x 2-1/2"
23	1706073	Carriage Bolt - 3/8" x 7"
24	1700407	Hex Nut - 3/8"
25	1700434	Lock Washer - 3/8"
26	1700429	Flat Washer - 3/8"
27	1127905	Hinge Post Bracket
28	1127908	Hinge Post Slide Bracket
29	1704416	Hex Head Cap Screw - 5/16" x 1"
30	1700428	Flat Washer - 5/16"
31	1700419	Nylon Lock Hex Nut - 5/16"
32	1127904	Stop Plate Mounting Bracket
33	1127902	Stop Plate
34	1128057	Replacement Solar Controller

ELECTRIC TURNING POINT™ BOW

ITEM	PART #	DESCRIPTION
	1117641	Electrical Parts Kit w/Rocker Switch* - 25-Amp Auto Rest [Includes 20; 22; 26; 27; 28; 30; 32; 37; 2 of 19, 23, 29, 31, 34 & 35; 4 of 21 & 33; 5 of 36]
	1126888	SMART3™ Receiver Kit w/Remote* - Turning Point™** [Includes 20; 22; 32; 2 of 19, 23, 34 & 35; 4 of 21, 33, 38, 39, 40 & 41]
	1109016	Two-Pole Connector w/Hardware - Vertical Pin [Includes 54; 58; 60; 61; 2 of 9, 10, 11, 42, 59 & 62]
1	1704181	Hex Nut - M12 x 1-3/4
2	1700437	Lock Washer - 1/2"
3	1117633	Actuator Shield
4	1704180	Flange Locking Nut - M12 x 1-3/4
5	1704130	Electric Linear Actuator
6	1701118	Spring Pin - 1/4" x 1-3/16"
7	1117623	Electric Turning Point™ Bow - 8" Rise
	1117622	Electric Turning Point™ Bow - 12" Rise
8	1704179	Hex Flange Cap Screw - M12 x 60
9	1700407	Hex Nut - 3/8"
10	1700434	Lock Washer - 3/8"
11	1700400	Self-tapping Screw - Non Corrosive Coating - 3/8" x 1"
12	1117628	Bow Pivot Bracket
13	1107006	Pivot Bracket Spacer
14	1110368	Bow Attachment Spring Assembly
15	1704185	Nylon Lock Nut - 1/4"
16	1117637	Limit Switch
17	1117643	Contact Bracket Offset Adapter
18	1703960	Hex Head Cap Screw - 1/4" x 1/2"
19	1704184	Nylon Lock Hex Nut - #6-32
20	1117647	Terminal Block Mounting Bracket
21	1701471	Self-Drilling Screw - #12 x 1"
22	1704190	3-Circuit Terminal Block
23	1704191	Machine Screw - 6-32 x 7/8"
24	1105333	Bow Rest - 8" Rise
	1105327	Bow Rest - 12" Rise
25	1105314	Bow Stop
26	1116020	Rocker Switch
27	1703661	Rocker Switch Mounting Bracket
28	1703896	Solenoid Cover
29	1701543	Nylon Lock Hex Nut - 1/4"
30	1703845	Motor-Reversing Solenoid
31	1704905	Hex Head Cap Screw - 1/4" x 1"
32	1704126	25-Amp Auto-Reset Circuit Breaker
33	1704177	Ring Terminal - 8 Ga. x 1/4" Stud
34	1704174	Ring Terminal - 8 Ga. x 3/8" Stud
35	1704175	Ring Terminal - 8 Ga. x #10 Stud
36	1703659	Push-On Terminal - 14 Ga. x 1/4" - Switch/Solenoid
37	1704153	Ring Terminal - 14 Ga. x 1/4" Stud
38	1702926	Hex Head Cap Screw - 5/16" x 7/8"
39	1704312	Motor-Reversing Solenoid
40	1704343	Hex Head Cap Screw - 1/4" x 1-1/2"
41	1700408	Hex Nut - 1/4"
42	1700427	Flat Washer - 1/4"
43	1118296	Modular Control Bracket
44	1118297	Insulating Plate
45	1118037	Plastic Washer - Black
46	1118250	Plastic Washer - Orange
47	1700436	Lock Washer - 1/4"
48	1704308	Flange Cap Screw - #10 x 1/2"
49	1703282	Rubber Grommet - 1-1/4" Insert
50	1701595	End Plug - 1"
51	1126881	SMART3™ Solenoid Cover w/Gasket
52	1704309	Solenoid Cover Gasket
53	1704369	Trim Seal (per foot)
54	1703231	Cable Tie - 8"
55	1704330	Rubber Insulating Boot
56	1126867	SMART3™ Remote
57	1117654	Dual-Conductor Wire - 8 Ga. - 30'
	1117653	Dual-Conductor Wire - 8 Ga. - 50'
	1117652	Dual-Conductor Wire - 8 Ga. - 75'
	1117651	Dual-Conductor Wire - 8 Ga. - 100'
	1704125	Dual-Conductor Wire - 8 Ga. (per foot)
58	1115385	Heavy-Duty Dual-Conductor Plug
59	1701045	Hex Head Cap Screw - 5/16" x 3/4"
60	1119557	HD Dual-Conductor Metal Socket w/Boot - Vertical Pin
61	1704573	Sealing Boot - Socket Half Dual-Conductor
62	1704946	Top Lock Flange Nut - 5/16"
63	1109015	Conductor Plug Mounting Bracket
	1704378	Dielectric Connector Protector (not shown)

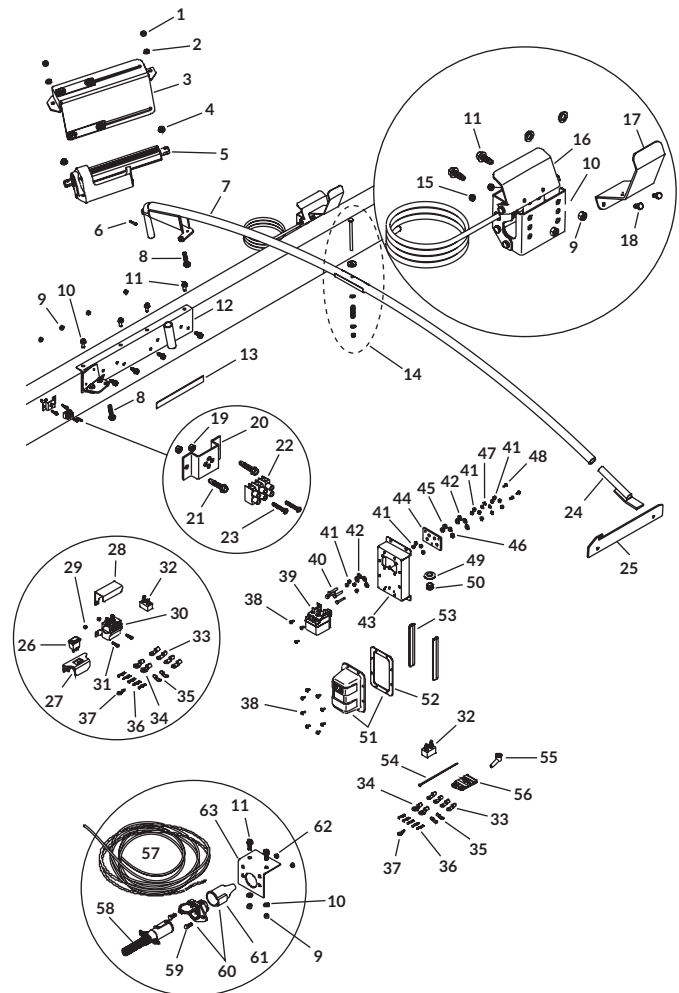

See asterisk items below for table on the left.

*Includes dielectric connector protector.

**SMART3™ receiver kit does NOT include SMARTwire™; will NOT operate in Express.

ORDERS

All orders are subject to written acceptance by Shur-Co®, LLC, PO Box 713, 2309 Shur-Lok Street, Yankton, South Dakota 57078-0713, USA. We are required by law to collect sales tax and F.E.T. taxes on products shipped to states where applicable. If tax exempt, a copy of your tax exempt certificate must accompany your order.

EXPEDITE/CANCELLATION/CHANGE FEES

In-stock parts orders placed by 10:00 a.m. (Central Time) normally ship the same day. (This varies with quantity/size of the order.) Standard lead time on tarps and hardware kits is generally five (5) to seven (7) working days; however, if you request that your order of tarps, hardware kits and/or complete tarp systems be expedited earlier than the normal lead time, there will be an extra charge of \$25. This fee is in addition to shipping and handling charges. Any change will generate an additional charge of \$25, and a cancellation will generate a 15 percent restocking fee. Lastly, once an order is in production, no changes can be made – the order is then considered final.

NOTE: We have no control over delivery dates – only ship dates.

SHIPPING

All orders are shipped F.O.B. from Shur-Co®, LLC, Yankton, SD; Vermillion, SD; Stuart, FL; Caldwell, ID; Decatur, IL; West Fargo, ND; Rootstown, OH; Brantford, Ontario, Canada; or Rochester, Kent, UK. No full freight will be allowed and no prepaid shipment accepted unless quoted and approved in writing prior to acceptance of order. All shipments are made by the most reasonable means in accordance with size and weight of order, unless specific routing instructions are furnished by customer. Shipments are made daily via U.P.S. and common carrier. Claims for shortages must be made within 10 days. Claims for damages or loss in transit must be made with the carrier. No collect calls will be accepted. To ensure delivery, we need your full street address and phone number. When you receive your shipment, examine it carefully. Be sure that all cartons listed on the delivery sheet are present and accounted for. Large items, like steel tubing, may be packaged separately. If a carton is damaged, open it and inspect contents before signing for delivery. If merchandise is damaged, describe the damage on the delivery receipt. Failure on your part to document damaged or missing merchandise on the delivery receipt releases carrier of liability; repair or replacement will be the customer's responsibility.

CREDIT TERMS

Shipments are made on a cash basis – no C.O.D.s. We accept American Express, Discover, VISA, MasterCard and checks by phone or mail. Prices subject to change without notice.

WARRANTY

We warrant that all new products are free from defects in materials and workmanship.* Warranty is effective if products are properly installed and used for the purpose for which they were intended and applies to original buyer only. Except as set forth above or as set forth in any product-specific warranty documentation, we make no other warranties, express or implied, including, but not limited to, warranties of merchantability or fitness for a particular use.

WARRANTY Continued

Returns for warranty must be accompanied by a Return Merchandise Authorization number (RMA#), obtained by calling Customer Service at 866-748-7435, and sent, with freight paid by us, to Shur-Co®, LLC, 2309 Shur-Lok Street, PO Box 713, Yankton, SD 57078-0713, USA. Products returned without an RMA# will be refused. When we issue the RMA#, we will also issue a call tag to have UPS (or other freight company) pick up the product. C.O.D. warranty returns will not be accepted. We will pay no storage charges for a warranty product return prior to pickup by us or the freight company. If a warranty product return is scheduled to be picked up by us, we will do so at our earliest convenience.

If the product returned is found, in our judgement, to be defective in material or workmanship, our obligation under this warranty is limited to repair or replacement of the product, which will be made by us. Repair or replacement will be at our discretion, with replacements being made using current products performing the equivalent function. Labor charges other than those incurred at our factory or customer-owned service location (see back cover for a listing of facilities), including, but not limited to, any labor to install a repaired or replacement product, are not covered under this warranty. All and any expenses associated with delivering defective products to our factory and delivering repaired or replacement products from our factory to the owner will be paid by us.

If the product returned is found, in our judgement, to be non-warrantable, the owner will be contacted to authorize repair, the purchase of a replacement product or return of the product, all of which will be at the owner's expense. Payment authorization must be received by us before any non-warrantable product is repaired, replaced or returned. All expenses associated with delivering the repaired non-warrantable product from our factory to the owner will be paid by the owner.

In no event will we be liable for damages of any kind to person, product or property, including, but not limited to, indirect, incidental, special, consequential or punitive damages, or damages for loss of profits or revenue, even if we have been advised of the possibility of such damages. There are no warranties for used products or products that have been repaired, altered, modified or subjected to misuse, negligence or accident. We will not repair or replace products that fail or malfunction due to ordinary wear and tear, except as expressly provided in a product-specific warranty. The use of non-Shur-Co®, LLC parts in conjunction with our products will void the product warranty.

*Certain products have specific warranties that differ from this warranty, i.e. motors and electronics. Product-specific warranty documentation is available for these items. In the event of a conflict between this warranty and a product-specific warranty, the product-specific warranty will govern. SEE THE FULL LISTING OF SHUR-CO® PATENTS ON OUR WEBSITE: shurco.com/patents.

RETURN POLICY

All sales are final. See WARRANTY section at left and above for information on warranty returns.

NOTE: No person is authorized to modify the foregoing conditions of sale whatsoever. All product listings, sizes, weights and manufacturing details in this catalog are subject to change without notice.

Copyright 2022 Shur-Co®, LLC

SERVICE TRUCK POWER KITS

By: Shur-Co®

“QUICK-DISCONNECT” CONNECTIONS

START HERE:

CONNECTOR BASE POWER KIT

Mounts on vehicle grill or other convenient location.

P/N 1128064 - *includes high-quality manual reset circuit breaker*

P/N 1128488 - *does not include circuit breaker*

- 4-ga. wire, 12' long
- Attaches directly to battery of vehicle
- SMARTwire™ is routed to outside of vehicle for convenience
- Sealed SMARTwire™ connector with plug when not in use
- If you plan on running motorized applications such as a tarp system or winch, it is recommended that you use P/N 1128064 as it offers added circuit protection included with the kit



BUILD YOUR PERSONALIZED KIT:

P/N 1128065 - HEAVY-DUTY 2-WAY CONDUCTOR PLUG

Provides power to trailers with horizontal or vertical power sockets.

- 6-ga. wire, 10' long
- Use with P/N 1128064
- Supplies temporary 12V power to any trailer with 2-conductor socket
- Compatible with both vertical pin and horizontal pin sockets
- Includes accessory bag

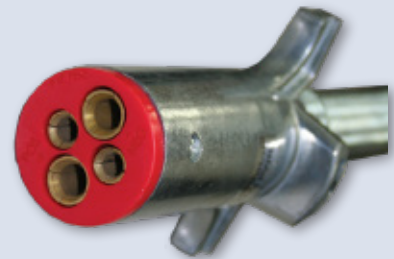

P/N 1128066 - HEAVY-DUTY 2-WAY CONNECTOR SOCKET

Ideal for farm machinery that may require frequent jump starts.

- 6-ga. wire, 3'6" long
- Permanent and convenient - includes mounting bracket and hardware
- Can also be installed with winches or other 12V motors
- Standard vertical, 2-pin style trailer socket
- Use with P/N 1128064 and P/N 1128065

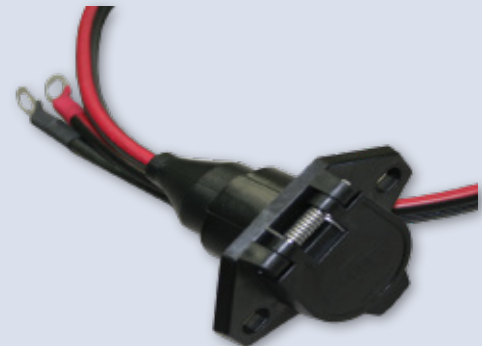

P/N 1128299 - HEAVY-DUTY SERVICE TRUCK ACCESSORY BAG

Plenty of room for all kit choices listed on this flyer.



P/N 1128067 - JUMPER CABLE KIT

Sealed SMARTwire™ connector between jumper cables/service truck.

- 4-ga. wire, 12' long
- High-quality, insulated cable clamps
- Use with P/N 1128064
- Includes accessory bag



P/N 1128410 - ROTARY SWITCH

Runs tarp systems that are typically operated by rocker switches in the cab.

- 6-ga. wire, 8' total length (4' on input side and 4' on output side)
- Heavy-duty design
- Includes accessory bag
- Built-in high quality manual reset breaker
- Use with P/N 1128064 or P/N 1128065



P/N 1128324 - SERVICE TRUCK LED WORK LIGHT

Light up the scene! LiteALL™ LED flood beam set into hinged brackets with magnetic base for optimal adjustability.

- Connected to connector base power kit using SMARTwire™ adapter cable
- 30,000 hours estimate
- IP67 waterproof Rating
- 1600 lumens
- Includes accessory bag
- Rubber coated magnetic base
- 24-watt output
- 1.8-amp draw



EXTENSION CABLES

Extends reach from service truck to accessories.

- 4-ga. wire
- Use with P/N 1128064 or P/N 1128488
- P/N 1128099 - 8'
- P/N 1128100 - 12'
- P/N 1128101 - 16'
- P/N 1128102 - 20'



P/N 1121480 - JUNCTION BLOCK POWER SPLITTER

Increase the number of sealed SMARTwire™ connections from one to three.

- Can be permanently installed on the service truck or on a trailer.





SALES, INSTALLATIONS, PARTS AND REPAIRS

World Headquarters
SHUR-CO® of SOUTH DAKOTA
2309 Shur-Lok St., Yankton
877.474.8726
FAX: 605.665.0501

SHUR-CO® of IDAHO
921 Garber St., Caldwell
208.455.1046
FAX: 208.459.1190

SHUR-CO® of ILLINOIS
3993 E. Mueller Ave., Decatur
866.356.0246
FAX: 217.877.8270

SHUR-CO® of VERMILLION
1212 N. Norbeck St., Vermillion
605.658.1020
FAX: 605.658.1022

SHUR-CO® of OHIO
4676 Lynn Rd., Rootstown
866.356.0242
FAX: 330.297.5599

SHUR-CO® of NORTH DAKOTA
1746 4th Ave. NW, West Fargo
877.868.4488
FAX: 701.277.1283

SHUR-CO® of CANADA
490 Egin St., Unit #2
Brantford, Ontario N3S 7P8
800.265.0823
FAX: 519.715.3997

Donovan® Brand Headquarters
SHUR-CO® of FLORIDA
3353 SE Gran Park Way, Stuart
800.327.8287
FAX: 772.287.0431

SHUR-CO® UK Limited
Rochester Airport Est., Unit 41
Laker Rd.
Rochester, Kent ME1 3QX
+44 (0) 1795.473499



FOLLOW US ON SOCIAL MEDIA!