



TARP SYSTEMS, PARTS & TARPS

P/N 1811728 Rev. A

OWNER'S MANUAL

SWAT[®]SA
SINGLE AXLE

**Waste Auto-Tarper
(12'-16' or 14'-18' Containers)**

READ BEFORE INSTALLING

3353 GRAN PARK WAY • STUART, FL 34997
PHONE: 1-800-327-8287 • FAX: 1-772-287-0431
www.DONOVAN-TARPS.com

SHIPPING. Orders are shipped F.O.B. from the Shur-Co®, LLC sites listed below. No full freight is allowed or prepaid shipment accepted unless quoted and approved in writing prior to acceptance of the order. All shipments are made by the most reasonable means in accordance with size and weight of order, unless specified routing instructions are furnished by the customer. Shipments are made daily via U.P.S. and common carrier. Claims for shortages must be made within 10 days. All claims for damages or loss in transit must be made with the carrier. No collect calls will be accepted. To ensure delivery of orders, we need your full street address and phone number. When you receive your shipment, examine it carefully. Be sure all cartons listed on the delivery sheet are accounted for. Large items may be packaged separately. If a carton is damaged, open it and inspect the contents before signing for delivery. If merchandise is damaged, describe damage on the delivery receipt. Failure on your part to document damaged or missing merchandise on the delivery receipt releases the carrier of all liability; repair or replacement will be the customer's responsibility.

WARRANTY. We warrant all new products are free of defects in materials and workmanship.* This warranty is effective if products are properly installed and used for the purpose for which they were intended and applies to the original buyer only. Except as set forth above or in any product-specific warranty documentation, we make no other warranties, express or implied, including but not limited to warranties of merchantability of fitness for a particular use.

Returns of a product for warranty must be accompanied by a Return Merchandise Authorization number (RMA#), obtained by calling Customer Service at 866-748-7435, and sent, with freight paid by us, to Shur-Co®, LLC, 2309 Shur-Lok St., PO Box 713, Yankton, SD 57078. All products returned without an RMA# will be refused. When we issue the RMA#, we will also issue a call tag to have UPS (or other freight company) pick up the product. C.O.D. returns not accepted. We will pay no storage fees for a warranty product return prior to pick by us or the freight company. If a warranty product return is scheduled to be picked up by us, we will pick up the product at our earliest convenience.

If a product returned is found, in our judgement, to be defective in material or workmanship, our obligation under this warranty is limited to the repair or replacement of the product, which will be made by us. Repair or replacement will be at our discretion, with replacements being made using current products performing in the equivalent function. Labor charges, other than those incurred at our factory, including, but not limited to, any labor to install a repaired or replacement product, are not covered under this warranty. All expenses associated with delivering defective products to our factory and delivering repaired or replacement products from our factory to the owner will be paid by us.

If the product returned is found, in our judgement, to be non-warrantable, the owner will be contacted to authorize repair work, purchase of a replacement product or return of the product, all of which will be at the owner's expense. Payment authorization must be received by us before any non-warrantable product is repaired, replaced or returned. All expenses associated with delivering the repaired non-warrantable product, a replacement product or the non-warrantable product from our factory to the owner will be paid by the owner.

In no event will we be liable for any damages of any kind to person, product or property, including but not limited to indirect, incidental, special, consequential or punitive damages, or damages for loss of profits or revenue, even if we have been advised of the possibility of such damages. There are no warranties for used products or products that have been repaired, altered, modified or subjected to misuse, negligence or accident. We will not repair or replace products that fail or malfunction due to ordinary wear and tear, except as expressly noted in a product-specific warranty. Use of non-Shur-Co®, LLC parts in conjunction with Shur-Co®, LLC products will void this product warranty.

*Certain products have specific warranties that differ from this warranty, for example motors and electronics. Product-specific warranty documentation is available for these items. In the event of a conflict between this warranty and a product-specific warranty, the product-specific warranty will govern.

RETURN POLICY. All sales final. See WARRANTY above for return details.

OTHER. All prices, product listings, sizes, weights and manufacturing details are subject to change without notice. No person is authorized to modify the foregoing conditions of sale whatsoever.

SHUR-CO®, LLC SERVICE AND DISTRIBUTION CENTERS

Corporate HQ and Outlet Store
SHUR-CO® of SOUTH DAKOTA
 2309 Shur-Lok St., Yankton, SD 57078
 Ph 800.474.8756 | Fax 605.665.0501

SHUR-CO® of FLORIDA
 3353 SE Gran Park Way, Stuart, FL 34997
 Ph 800.327.8287 | Fax 772.287.0431

SHUR-CO® of IDAHO
 610 N. 16th Ave., Caldwell, ID 83607
 Ph 866.356.0246 | Fax 217.877.8270

SHUR-CO® of ILLINOIS
 3993 E. Mueller Ave., Decatur, IL 62526
 Ph 866.356.0246 | Fax 217.877.8270

SHUR-CO® of NORTH DAKOTA
 1746 4th Ave. NW, West Fargo, ND 58078
 Ph 877.868.4488 | Fax 701.277.1283

SHUR-CO® of OHIO
 4676 Lynn Rd.
 Rootstown, OH 44266
 Ph 866.356.0242 | Fax 330.297.5599

SHUR-CO® of VERMILLION
 1212 N. Norbeck St., Vermillion, SD
 Ph 605.658.1020 | Fax 605.658.1022

SHUR-CO® of CANADA
 490 Elgin St., Unit #1
 Brantford, Ontario N3S 7P8
 Ph 800.265.0823 | Fax 519.751.3997

SHUR-CO® UK, Ltd.
 Unit 41 Rochester Airport Estates
 Laker Rd., Rochester, Kent ME1 3QX
 Ph +44 (0)1795.473499
 Fax +44 (0)871.272.8278

For more information, log on to our website:

www.shurtite.com

1-877-474-8726 (U.S.) • 1-800-265-0823 (Canada)

MESSAGE TO OWNERS

Thank you for buying this tarping system from Shur-Co®. We appreciate your confidence in our products. Please read and thoroughly understand this manual before installing and/or operating this system.

Pay particular attention to important safety and operating instructions, as well as warnings and cautions. The hazard symbol  is used to alert users to potentially hazardous conditions and is followed by caution, warning or danger messages.

Failure to READ AND FOLLOW INSTRUCTIONS could result in failure of your tarping system and/or personal injury. Your trailer requirements may, however, call for minor variations to these instructions.

Please inspect your tarping system periodically. Repair or replace worn or damaged parts to your system.

**QUESTIONS? CALL OUR HELP LINE:
1-866-748-7435
MON-FRI 8 AM-5 PM CENTRAL TIME**

SAFETY

We at Shur-Co® are concerned with your safety and the safety of all those operating this system. Therefore, we have provided safety decals at various locations on your tarping system. Keep decals as clean as possible at all times. Replace any decal that has become worn or damaged, painted over or otherwise difficult to read. Replacement decals are available through Shur-Co®/Donovan dealers.

SAFETY INSTRUCTIONS

1. Do not activate control lever unless moving parts are in view.
2. Before opening cover, make sure no persons or obstructions are on other side of truck out of view.
3. Keep body and clothing away from moving parts.
4. Do not raise tower or operate arms while truck is under power lines.
5. Disengage PTO and turn off truck before serving or repairing system.
6. Noise level is less than 72 dBa.
7. Replace warning labels that become unreadable.
8. Always wear safety glasses during installation.

RUST PREVENTION

To prevent rust, paint all exposed metal, such as weld seams and/or metal exposed by grinding or cutting, with corrosion-resistant paint.

TABLE OF CONTENTS

Hardware Identification..... 4
 Gantry & Tarp Roll Base/Rest..... 5-6
 Pivot Assemblies 7-10
 Tarp & Tarp Roller..... 11-12
 Arms..... 13-15
 Hydraulic System Schematic (Wet System) 16-19
 Diverter Schematic for Hook Lift/High Pressure Systems 20
 Hydraulic System 21-23
 Hydraulic System Schematic (Self-Contained System)..... 24
 Self-Contained System 25
 Hydraulic Pump & Pump Enclosure 26-27
 Hydraulic Fittings, Hoses & Valve 28-29
 12V Electrical Connections & Wiring 30-32
 Fill, Bleed & Test System 33-34
 LiteALL™ 35-36
 Decal Placement 37
 Maintenance & Inspection 38
 Replacement Parts..... 39-43

 CAUTION

Before beginning installation, read and understand instructions completely. Unpack kit components, identify components in instructions and become familiar with them.

TOOLS REQUIRED

1. Wrench Set
2. Ratcheting Socket Wrench
3. Socket Set
4. Hammer
5. Tape Measure
6. Flat Head or Phillips Screwdriver
7. Grinder
8. Pliers
9. Metal Saw
10. Steel Welder
11. Drill Driver w/5/16" Hex Driver
12. Allen Wrench
13. Square

MAINTENANCE

- Tighten any loose bolts.
- Replace damaged/bent parts.
- Replace worn or broken springs.
- Replace/repair worn or damaged tarps.



1809472 Self-Tapping Screw - #10 x 1/2"



1704906 Carriage Screw - 1/4" x 1/2" (Gr. 5)

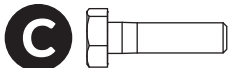

1700381 Cap Screw - 1/4" x 1" (Gr. 5)

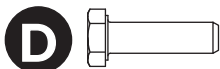

1704416 Cap Screw - 5/16" x 1" (Gr. 2)

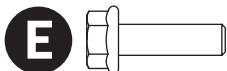

1809469 Hex Flange Cap Screw - 5/16" x 1" (Gr. 5)

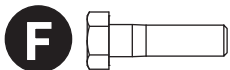

1701208 Cap Screw - 5/16" x 1-1/4" (Gr. 5)

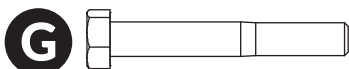

1808850 Cap Screw - 5/16" x 2-1/4" (Gr. 8)

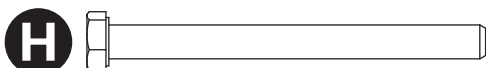

1201022 Cap Screw - 5/16" x 3-1/2" (Gr. 5)

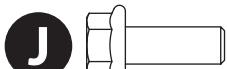

1809468 Hex Flange Cap Screw - 3/8" x 1" (Gr. 8)

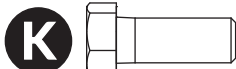

1701061 Cap Screw - 3/8" x 1" (Gr. 5)



1700371 Cap Screw - 3/8" x 3" (Gr. 5)



1704072 Cap Screw - 7/16" x 2-1/2" (Gr. 5)

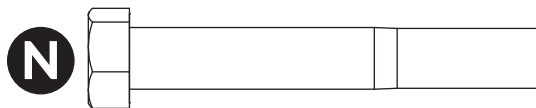

1808848 Cap Screw - 1/2" x 3-1/2" (Gr. 8)



1808849 Cap Screw - 1/2" x 4-1/2" (Gr. 8)



1701543 Nylock Lock Nut - 1/4" (Gr. 2)



1700408 Hex Nut - 1/4" (Gr. 5)



1700419 Nylock Lock Nut 5/16" (Gr. 5)



1700411 Hex Nut - 5/16"



1702492 Top Lock Nut - 5/16"



1809471 Jam Nut - 5/16"



1702668 Top Lock Nut - 3/8" (Gr. 5)



1808852 Hex Nut - 7/16" (Gr. 5)



1708847 Hex Nut - 1/2" (Gr. 5)



1700436 Lock Washer - 1/4"



1704912 Lock Washer - 5/16"



1700433 Lock Washer - 5/16"

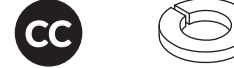

1700434 Lock Washer - 3/8"



1808854 Lock Washer - 7/16"



1808853 Flat Washer - 7/16"



1700437 Lock Washer - 1/2"

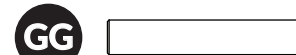

1809470 Threaded Stud - 5/16" x 1-3/4"

TARP INSPECTION

Tarp length: Inspect components of kit and compare with parts list enclosed. Measure tarp length with slight tension applied. Compare actual tarp length with length stated on sheet attached to tarp. If actual tarp length does not match length on sheet, do not proceed. Call your local dealer or call Shur-Co® Customer Service at 1-866-748-7435.

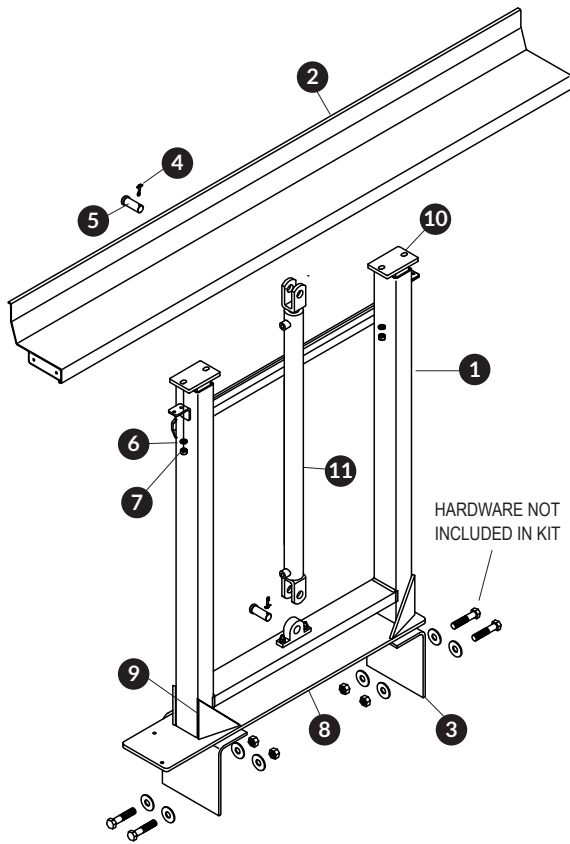

Item	Part #	Description
1.	1809152	Gantry Base Assembly
2.	1809147	Tarp Roll Base Rest Assembly
3.	1809208	Chassis Mounting Angle
4.	1202450	Cotter Pin - 3/16" x 1 1/2"
5.	1809013	Clevis Pin - 1" x 2.20"
6.	1700437	Lock Washer - 1/2"
7.	1808847	Hex Nut - 1/2"
8.	1809206	Gantry Mounting Plate
9.	1809207	Gantry Mounting Gusset
10.	1808871	Gantry Telescoping Legs
11.	1808891	Hydraulic Cylinder - 36"

STEP 1: Determine suitable location between cab and hoist tilt frame on truck to mount gantry with tarp roll base/rest. Allow enough clearance between cab and tilt frame to provide minimum of 4" between cab and front of gantry legs.

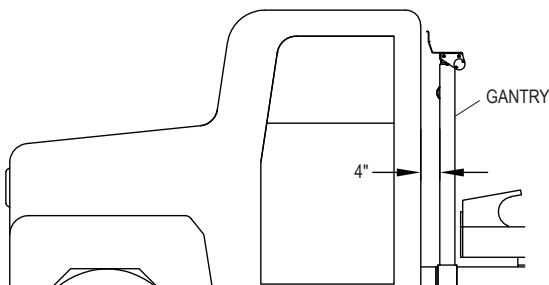

NOTE: Provide minimum of 4" clearance between cab and front of gantry legs to allow tarp roll base/rest to travel up and down. If existing exhaust system, hydraulic system or electrical components are located between tilt frame and cab, adjust position of components as needed to achieve clearance for gantry installation.

STEP 2: Chassis/frame mounting angles. Fasten angles to frame with grade 8 fasteners (not included) or weld to existing plates/brackets on frame (do not weld directly to frame; see caution below).

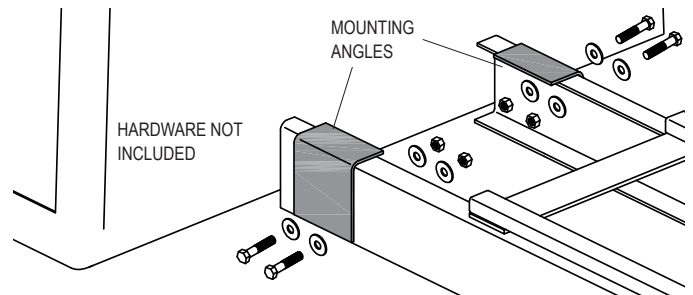

CAUTION
Do not weld directly to truck frame as it may weaken frame and will void warranty on truck. If drilling into chassis/frame, do not drill into flange or closer to flange than holes drilled by truck manufacturer.

STEP 2B: Gantry mounting plate. Lay gantry mounting plate over chassis mounting angles. Center plate over angles and weld onto angles.

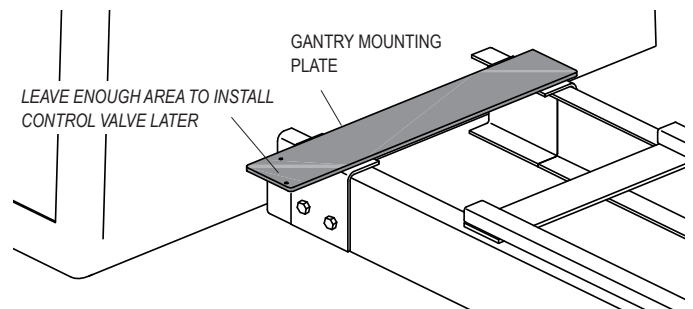

STEP 3A: Place gantry base assembly on gantry mounting plate and make sure gantry is square to hoist and frame, level from side to side and plumb vertically.

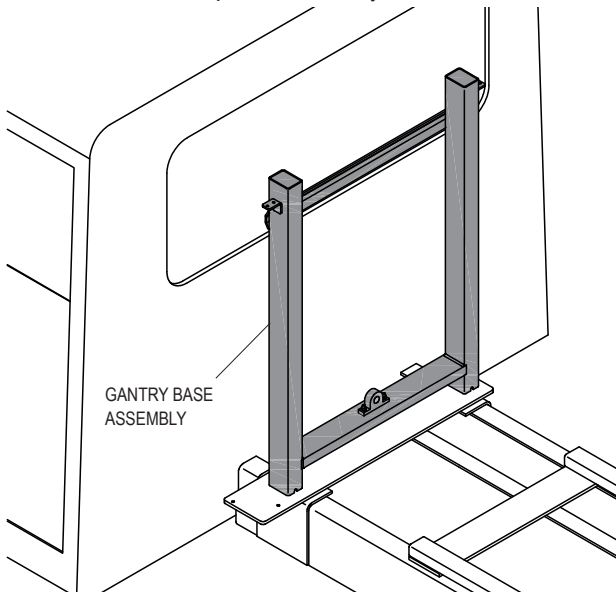

STEP 3B: Weld gantry mounting gussets to gantry legs and plate to stabilize and strengthen gantry mounting.

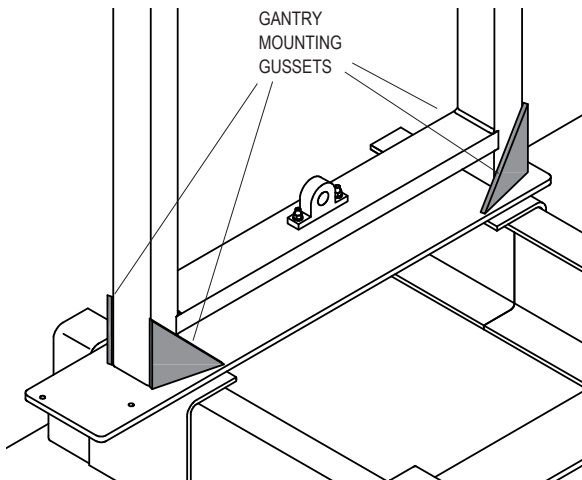

STEP 4A: Insert gantry legs into gantry base tubes. Place tarp roll base/rest on top of gantry legs.

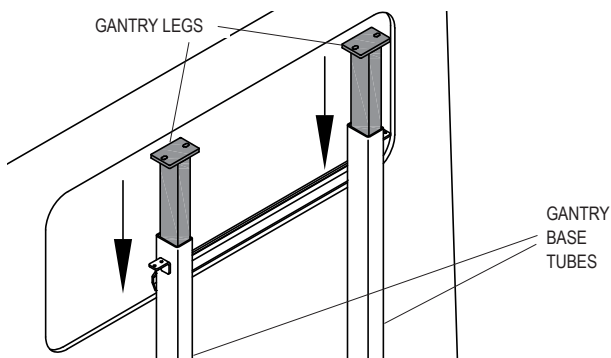

STEP 4B: Align holes and fasten roll base/rest to gantry legs with 1/2" nuts and lock washers.

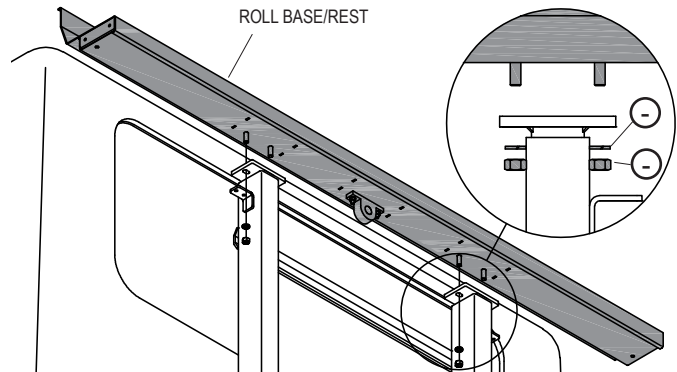

STEP 5: Position 36" stroke cylinder on gantry with ports facing driver side of truck. Secure cylinder onto clevis eye pads on gantry base and tarp roll base/rest with supplied clevis pins and cotter pins.

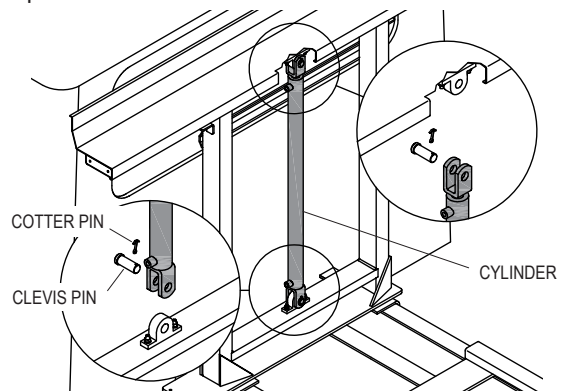

NOTE: Exhaust stack may interfere with tarp roll base/rest as base/rest moves up and down. Install elbows into stack as needed to correct.

⚠ CAUTION
 Tarping system is designed for use with specific container length. Containers of different lengths can be used, as long as rear of containers are located at designated position on trailer. Short stops may be used to correctly locate container.

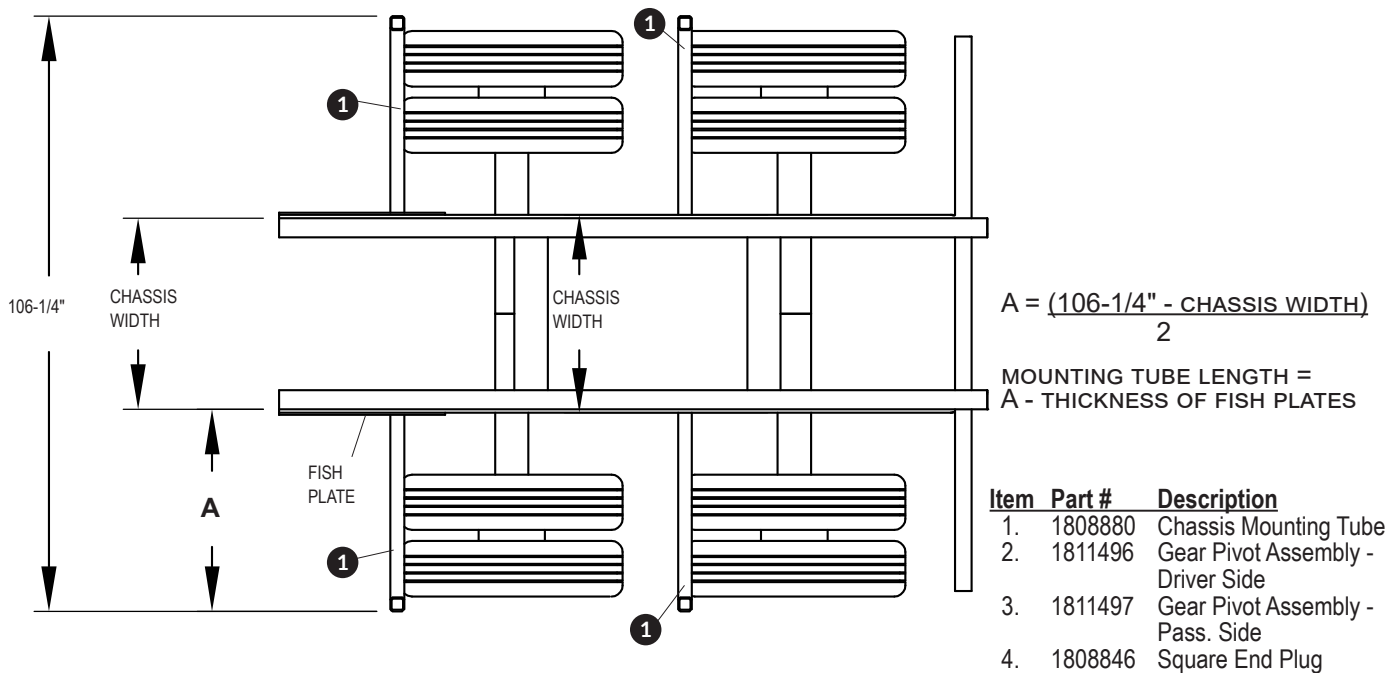

NOTE: Pivot assemblies and arms must be mounted to fabricated structure bolted to chassis/frame. Structure must extend away from chassis/frame so pivot assemblies will have clearance to allow for widest container to be carried on truck.

NOTE: Outside width from driver side pivot pin to passenger side pivot pin cannot exceed 108" to comply with federal DOT regulations. Check state and local DOT to determine if standards differ. Mount system in compliance with state and local regulations.

In order to provide maximum clearance for loading containers, these instructions are based on placing pivots just inside 108" maximum width allowed by federal DOT regulations.

Keep in mind:

- Do not weld directly to chassis/frame as this can weaken frame. Weld structure to "fish plates" which are drilled and bolted to chassis/frame or weld directly to existing plates already attached to chassis/frame.
- Do not use fasteners/hardware below grade 8.
- Make sure fabricated structure is supported and gusseted well. There should be no flexing of structure holding pivot assemblies. Structure must be as rigid as possible.
- When mounting, pivot assemblies must be:
 - a. Plumb, level and square vertically and horizontally.
 - b. Parallel to chassis/frame.
 - c. High enough to allow access to tires.
 - d. Equally extended from chassis/frame on both sides of truck.

NOTE: To aid in fabricating structure necessary to support pivot assemblies, four chassis/frame mounting tube assemblies are provided in kit. Mounting assemblies are longer than necessary (horizontally and vertically) in order to allow fitting on varied truck configurations.

STEP 1: To determine length of horizontal portion of chassis/frame mounting tubes, first measure outside width of chassis/frame. Subtract measurement from 106-1/4" and divide by 2 to determine how far each chassis/frame mounting tube must extend from chassis/frame to support pivot assemblies in correct location. Determine final length of mounting tubes by subtracting thickness of "fish plates" on chassis/frame to which mounting tubes will be welded.

$$A = \frac{(106-1/4" - \text{CHASSIS WIDTH})}{2}$$

MOUNTING TUBE LENGTH =
A - THICKNESS OF FISH PLATES

NOTE: "Fish plates" may already be bolted/welded to frame or may need to be fabricated and bolted to frame. If plate thicknesses vary from one mounting tube location to another, length of mounting tubes must also vary. If "fish plates" are equally thick, length will be equal for all four mounting tubes.

EXAMPLES OF GUSSETING FOR RIGID PIVOT ASSEMBLIES

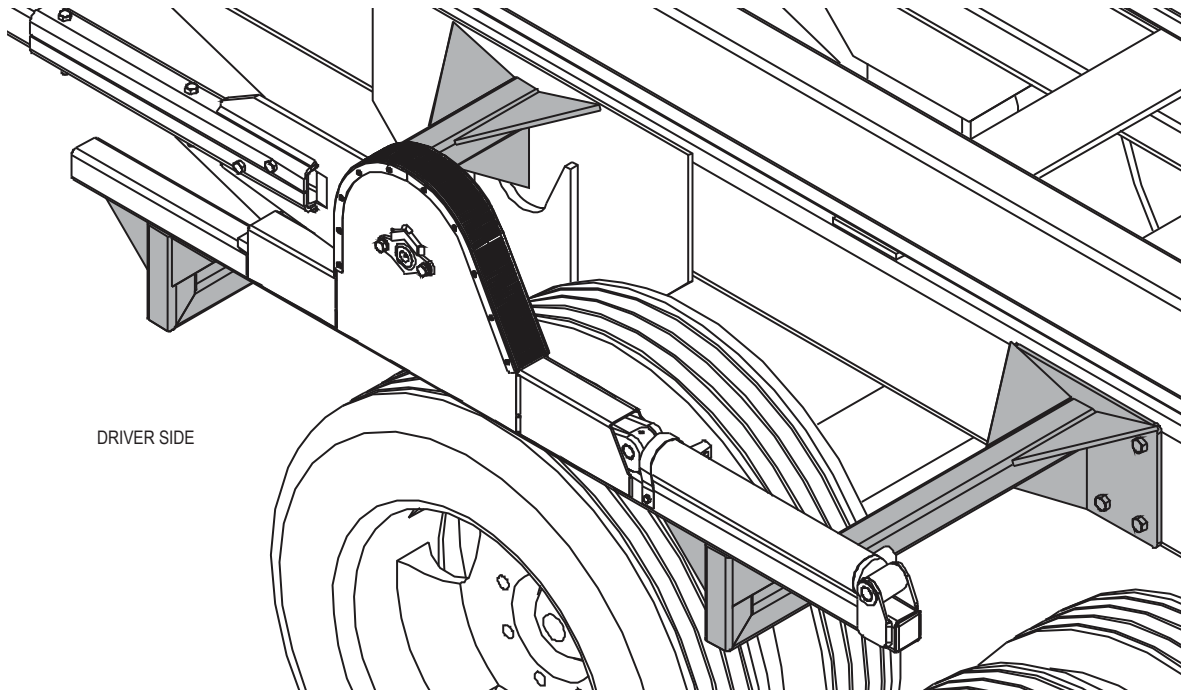
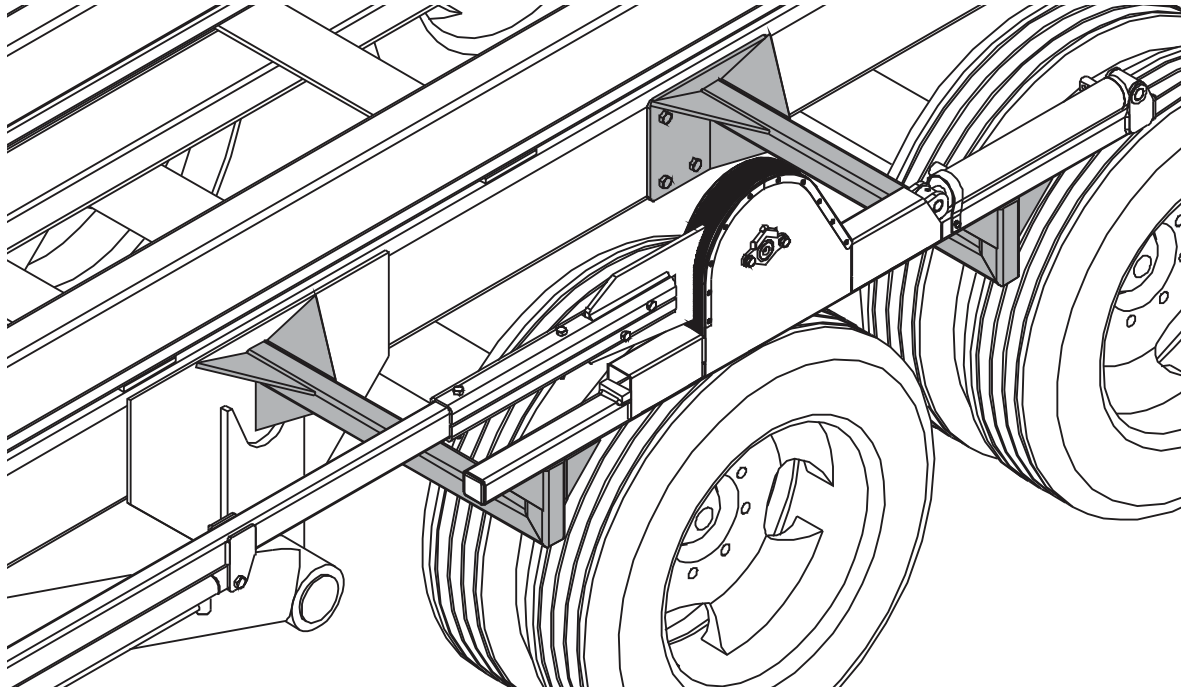

STEP 2: Determine pivot pin location. There are two options for the pivot pin location to choose from, based on the length range of containers the truck will be transporting.

Option 1: For trucks hauling 14 ft. to 18 ft. containers. With a tape measure, measure from rear face of a gantry leg and make a mark on frame/chassis at 104". Transfer mark as needed to locate pivot pin during pivot assembly installation.

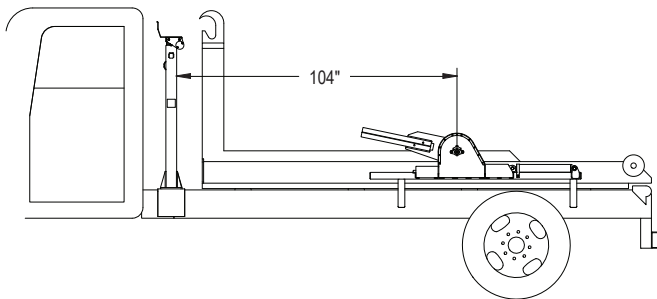

Option 2: For trucks hauling 12 ft. to 16 ft. containers. With a tape measure, measure from rear face of a gantry leg and make a mark on frame/chassis at 79". Transfer mark as needed to locate pivot pin during pivot assembly installation.

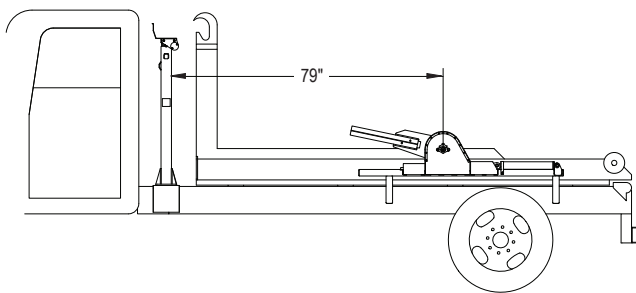

NOTE: Do not locate pivot pin any closer to the gantry leg than 79" specified, or tarp roller will not be able to land on tarp cradle. It is acceptable to locate the pin an inch or two farther away, at 80" or 81" for example, but this will extend the minimum distance when covering.

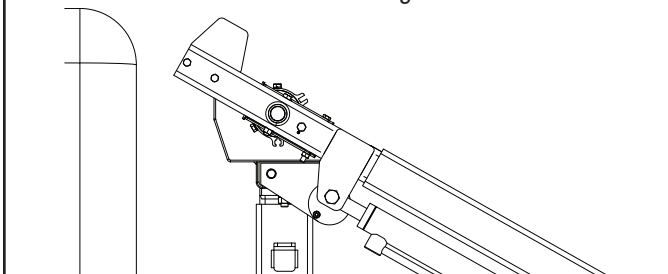

STEP 3: To determine height of pivot assembly, place straight edge across hoist rails and measure to bottom of fenders. Do not mount pivot assembly lower than bottom of fenders (to allow for tire changing). Measure from straight edge to bottom of fender on one side of truck and record measurement. Verify mounting tubes are plumb and square to hoist, then tack weld in place.

NOTE: Top of mounting tubes cannot be lower than fender to allow clearance for tire change.

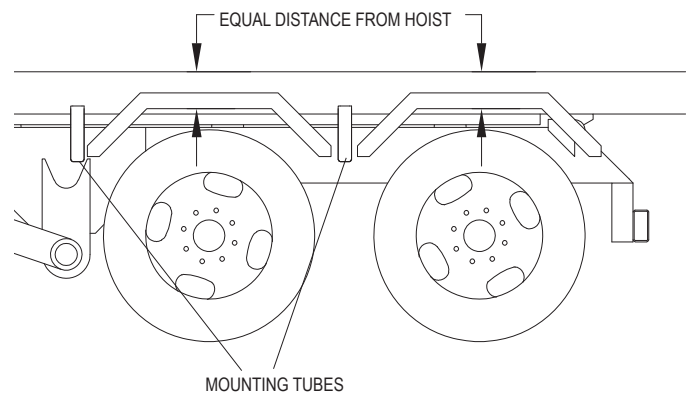

NOTE: When setting pivot assembly height, locate chassis/frame mounting tubes in middle of chassis. This will allow room to add gussets above or below mounting tubes for added strength.

STEP 4: Using straight edge, measure from straight edge to measurement recorded in step 3. Mark vertical portion of chassis/frame mounting tubes at this point and cut tubes. Reinstall mounting tubes and verify tubes are square, plumb and at correct height.

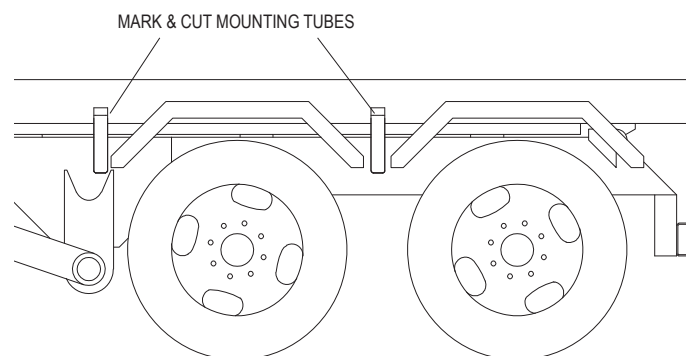

STEP 5: Place pivot assembly on top of tubes, aligning center of pivot pin (grease fitting) vertically with pivot point mark determined in step 2. Measure from hoist to pivot assembly at front and rear to verify that pivot assembly is parallel to hoist. Plumb pivot assembly vertically and tack weld in place. Make sure pivot portion of assembly is straight and parallel to hoist. If not, adjust pivot assembly in or out as needed. Repeat process on other side.

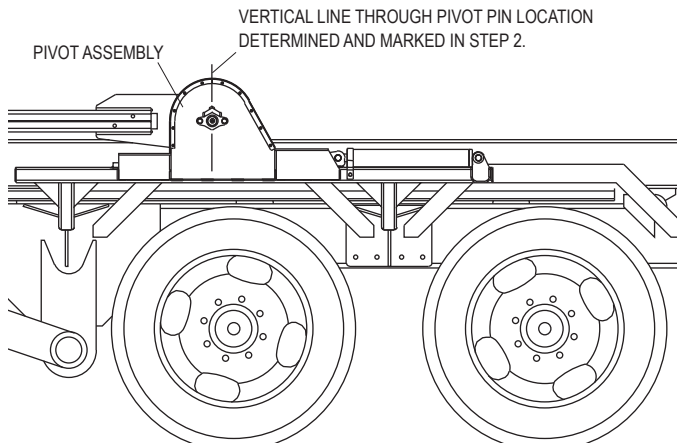

NOTE: To verify pivot points are aligned, measure diagonally from gantry to each pivot pin.

STEP 6: Measure across truck and verify outside edges of pivot pins are maximum of 108" apart. Add gussets between chassis/frame mounting tubes and "fish plates" in front to rear and up and down locations for added strength. Weld everything securely.

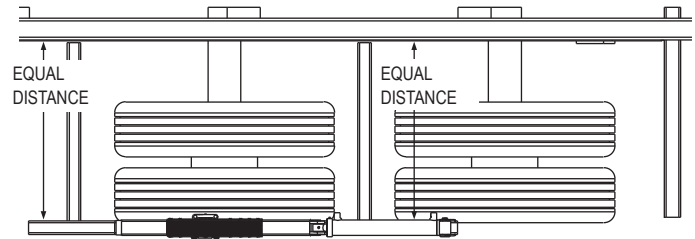

NOTE: Small amount of inward and outward movement is built into pivot assembly.

⚠ WARNING

Take precautions to make sure roller will not fall off roll base/rest until arms are installed.

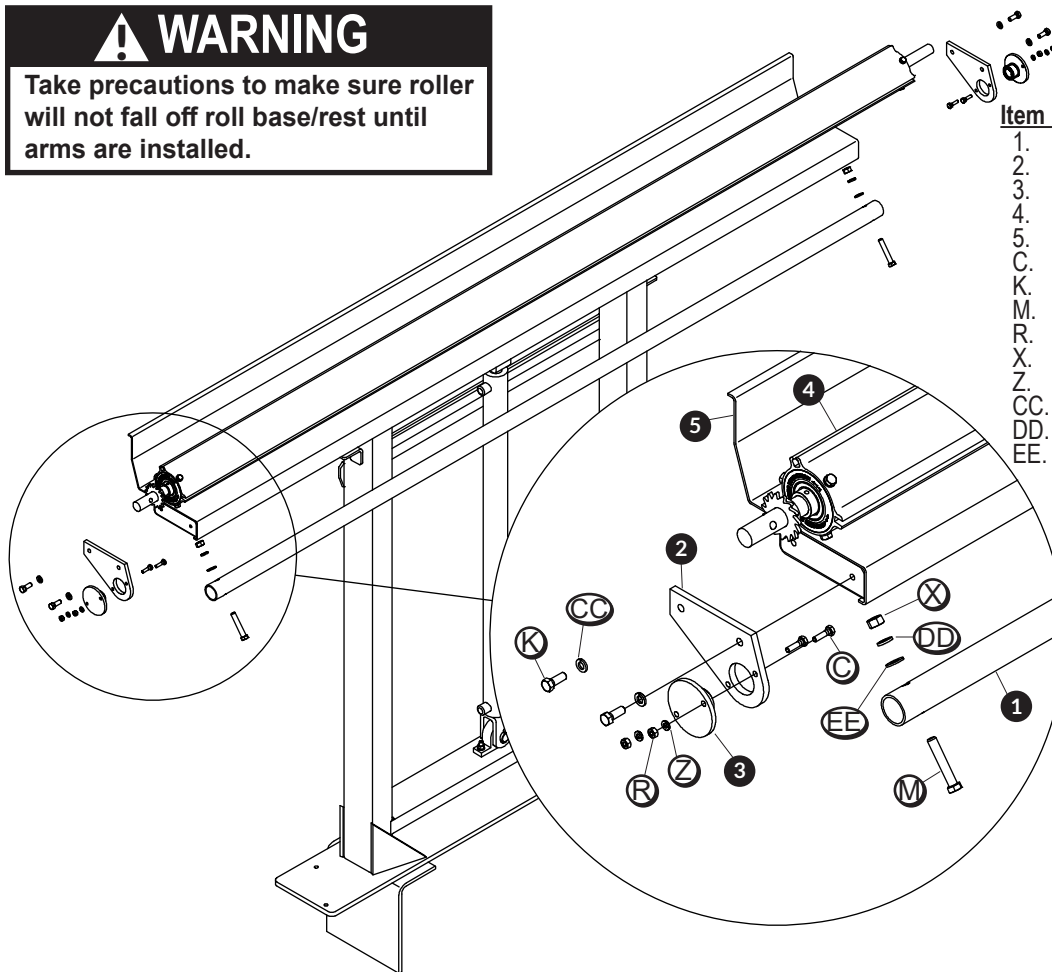

Item	Part #	Description
1.	1808865	Tarp Tube
2.	1808866	Tarp Tube Bracket
3.	1809148	Tarp Tube Cap
4.	1803805	Spring-Loaded Tarp Roller
5.	1809147	Tarp Roll Base Rest
C.	1700381	Cap Screw - 1/4" x 1"
K.	1701061	Cap Screw - 3/8" x 1"
M.	1704072	Cap Screw - 7/16" x 2-1/2"
R.	1700408	Hex Nut - 1/4"
X.	1808852	Hex Nut - 7/16"
Z.	1700436	Lock Washer - 1/4"
CC.	1700434	Lock Washer - 3/8"
DD.	1808854	Lock Washer - 7/16"
EE.	1808853	Flat Washer - 7/16"

STEP 1: Spread tarp on ground with reinforced side down. Locate tarp pocket at front of tarp.

NOTE: Tarp pocket will be used with tarp tube and tarp tube brackets to attach this end of tarp to tarp roll base/rest.

STEP 2: Place spring-loaded roller assembly on top of tarp at end opposite of tarp tube pocket (rear of tarp). Roller assembly must be oriented so driver side end (with gear and decals) is on left side of tarp as seen from rear of tarp.

STEP 3A: Grommets and screws option. Fasten tarp to roller with 1/4" x 3/4" screws, fender washers and 1/4" square nuts. Align center of tarp with center of roller shaft (not roller extension). Center of roller shaft is 54" from end of its roller shaft. With center of tarp at center of roller shaft, start by fastening middle grommet and work outward from center on both sides.

STEP 3B: Spline option. Slide spline in tarp into groove in roller bar. Center of roller shaft is 54" from its end. Place mark at this location and center tarp.

NOTE: Tarp will not appear to be centered on roller because aluminum roller is offset toward driver side.

STEP 4: Roll roller tube and tarp from rear to front, making sure flap is on bottom for flap tarps. Tarp must not be wider than roller, and tarp must be wound evenly onto roller.

STEP 5: Place roller with tarp on top of tarp-roll base/rest so driver side of roller (with hole in end of shaft) is on driver side of truck and tarp hangs 6" to 8" below rear tarp/roll base rest.

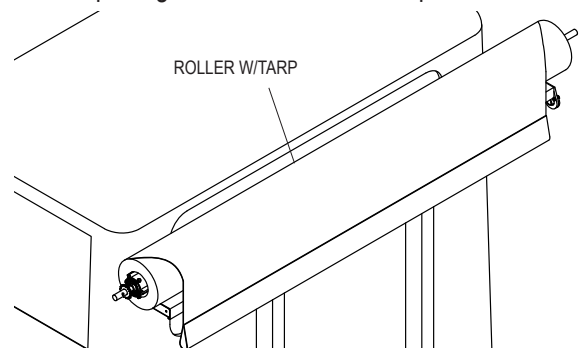

STEP 6: Fasten tarp tube brackets to ends of tarp/roll base rest with screws **K** and washers **CC**.

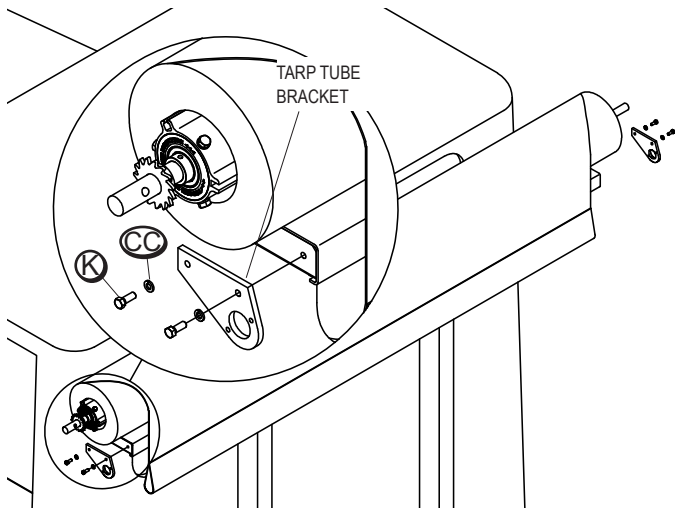

STEP 7: Insert tarp tube into tarp pocket and fasten to tarp with screws **M**, flat washers **EE**, lock washers **DD** and nuts **X**.

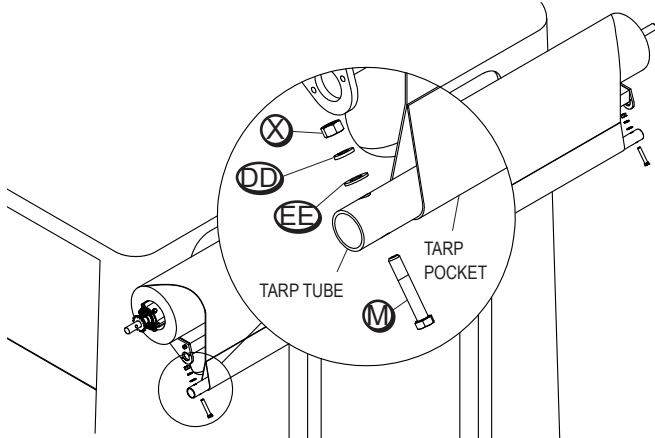

STEP 8: Slide ends of tarp tube into tarp tube brackets. Fasten tarp tube caps to tarp tube brackets with screws **C**, washers **Z** and nuts **R**.

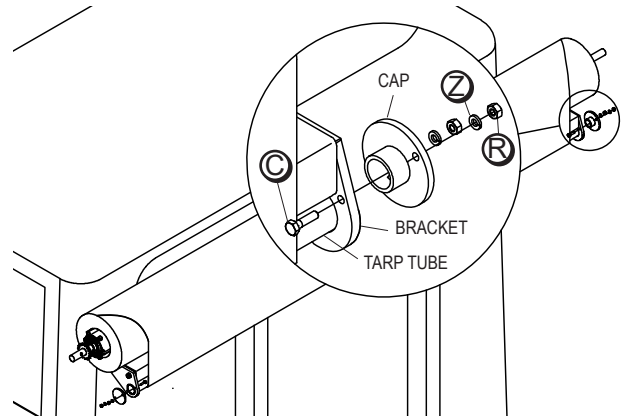

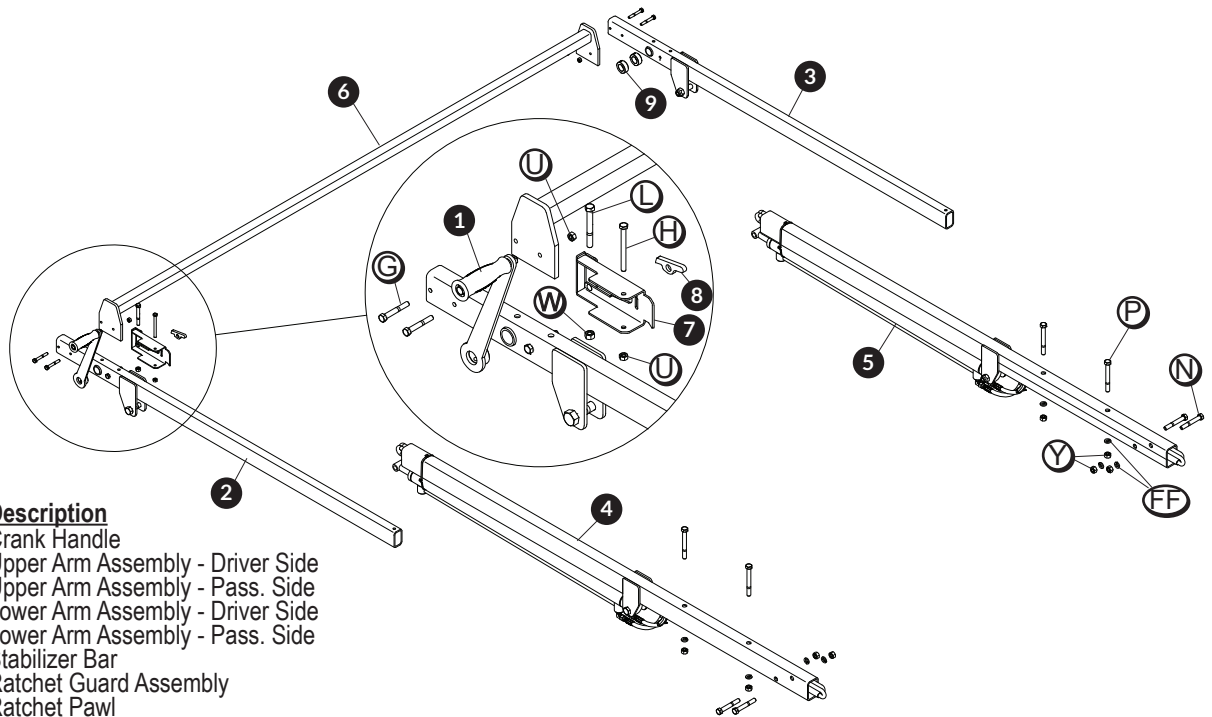

Item	Part #	Description
1.	1809177	Crank Handle
2.	1811491	Upper Arm Assembly - Driver Side
3.	1811492	Upper Arm Assembly - Pass. Side
4.	1810404	Lower Arm Assembly - Driver Side
5.	1810405	Lower Arm Assembly - Pass. Side
6.	1808873	Stabilizer Bar
7.	1809009	Ratchet Guard Assembly
8.	1809209	Ratchet Pawl
9.	1808855	Locking Collar - 1" ID
G.	1808850	Cap Screw - 5/16" x 2-1/4"
H.	1201022	Cap Screw - 5/16" x 3-1/2"
L.	1700371	Cap Screw - 3/8" x 3"
N.	1808848	Cap Screw - 1/2" x 3-1/2"
P.	1808849	Cap Screw - 1/2" x 4-1/2"
U.	1702492	Top Lock Nut - 5/16"
W.	1702668	Top Lock Nut - 3/8"
Y.	1808847	Hex Nut - 1/2"
FF.	1700437	Lock Washer - 1/2"

STEP 1: Driver side arm. Insert base end of lower arm into driver side pivot arm while carefully guiding hydraulic hoses at bottom of lower arm to enter channel-shaped section of pivot arm and exit between large pivot arm plate and channels on inside of pivot assemblies.

NOTE: Hoses must exit pivot arm channel on inner side, then route through plastic hose guide/swivel on inside end of pivot pin.

STEP 2: Fasten lower arm to pivot arm with screws **N** through horizontal holes and screws **P** through vertical holes. Secure with lock washers **FF** and nuts **Y**.

SLIDE HOSES INSIDE CHANNELS & EXIT BETWEEN CHANNELS & LARGE PLATE ON INBOARD SIDE OF PIVOT ASSEMBLY. ROUTE THROUGH PLASTIC HOSE PIVOT/SWIVEL GUIDE.

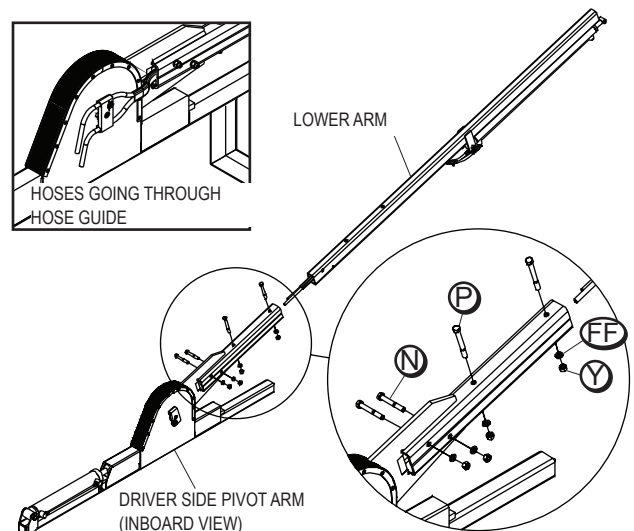

STEP 3: Slide driver side upper arm with ratchet pawl and spring into lower arm. Lift and extend driver side arm and slide hole in upper arm onto end of tarp roller shaft until pawl engages ratchet gear on tarp roller shaft. Temporarily install screw **Ⓛ** through holes in upper arm and tarp roller shaft. Arm extension cylinder can be fastened to upper arm. If cylinder is too tight to be moved by hand, complete this step after installing hydraulics.

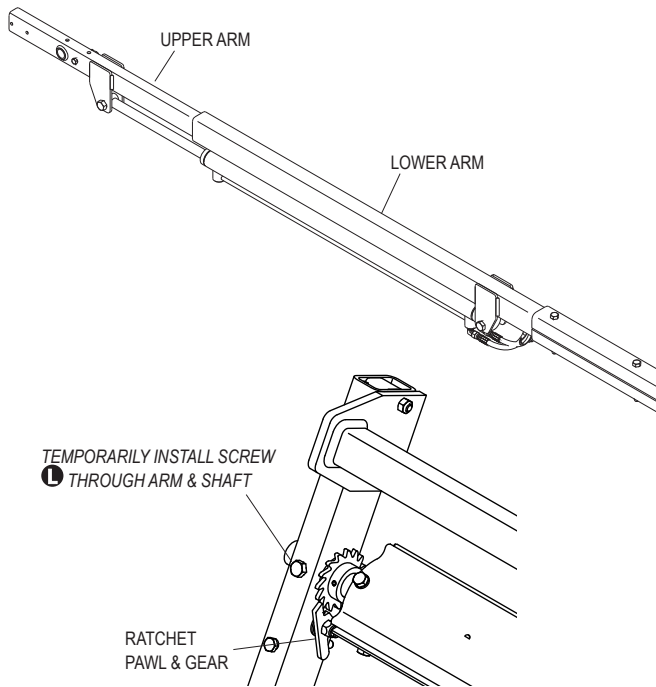

STEP 4: Install passenger side lower and upper arms in same manner as driver side arm. Before sliding upper arm extension onto tarp roller shaft, slide 1" locking collar onto roller shaft. Slide upper arm extension onto tarp roller shaft. Slide second 1" locking collar onto outside of upper arm. Slide roller assembly toward driver side to be sure ratchet pawl and gear are engaged, then tighten set screws on outer locking collar.

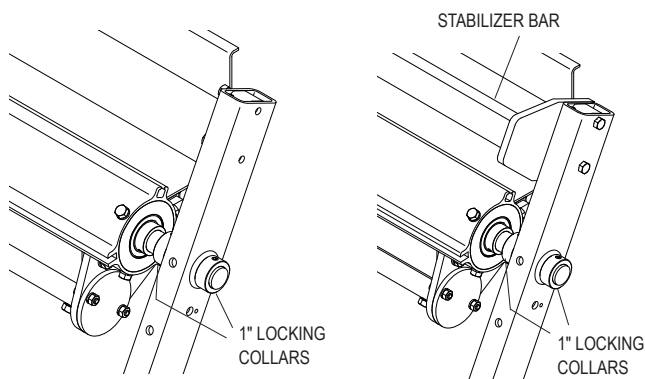

STEP 5A: Install stabilizer bar between arms with bar toward rear of truck. Fasten securely with screws **ⓐ** and lock nuts **Ⓤ**.

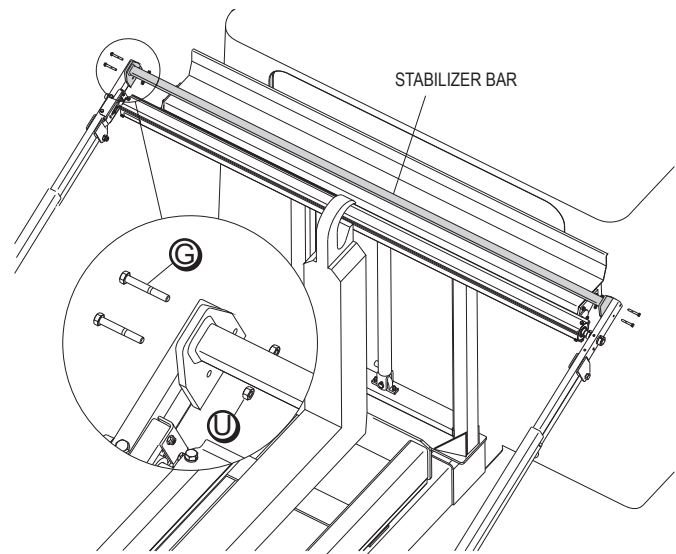

STEP 5B: Slide locking collars tight against upper arm. Outer locking collar should be near flush with end of shaft. Snug set screw on outer locking collar and remove set screw on inner collar. Hold collar tight against arm and, using set screw hole as guide, drill small dimple in roller shaft with 3/16" bit. Using thread locker, reinstall set screw so screw bites into dimple in shaft. Repeat for outer shaft collar and set screw.

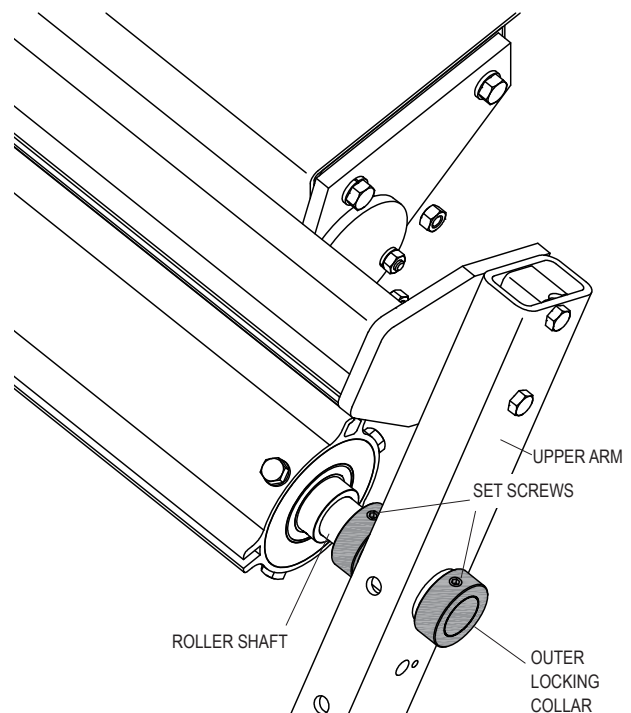

STEP 6: To install ratchet guard onto driver side arm, loosen lock nuts on guard and open end gate. Slide guard over ratchet pawl and gear, then close gate and tighten fasteners. Fasten guard to arm with screw **H** and top lock nut **U**.

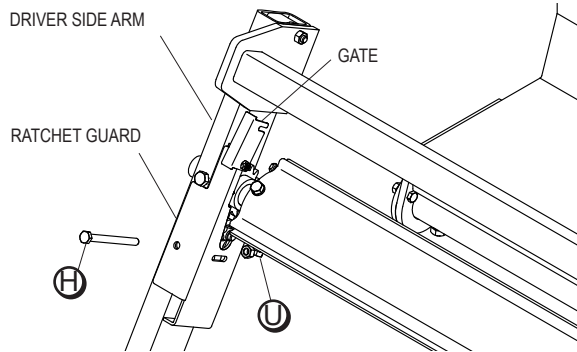

STEP 7: Install roller bar winding handle onto driver side of roller shaft and tighten set screw. Remove 3/8" cap screw going through arm and roller shaft. Do not let go of crank handle while screw is removed. Turn handle seven full revolutions counterclockwise, following decals on tarp roller. Reinsert cap screw through arm and roller shaft. Secure 3/8" cap screw with top lock nut. Remove crank handle from shaft and store in secure place on truck.

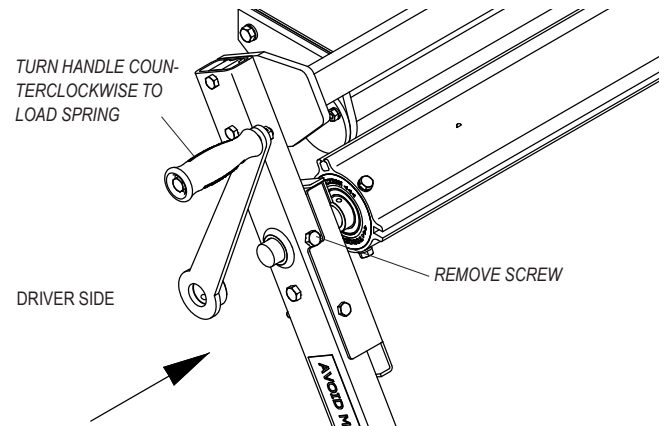

CAUTION

Maintain firm grip on crank handle until cap screw has been inserted into arm and shaft.

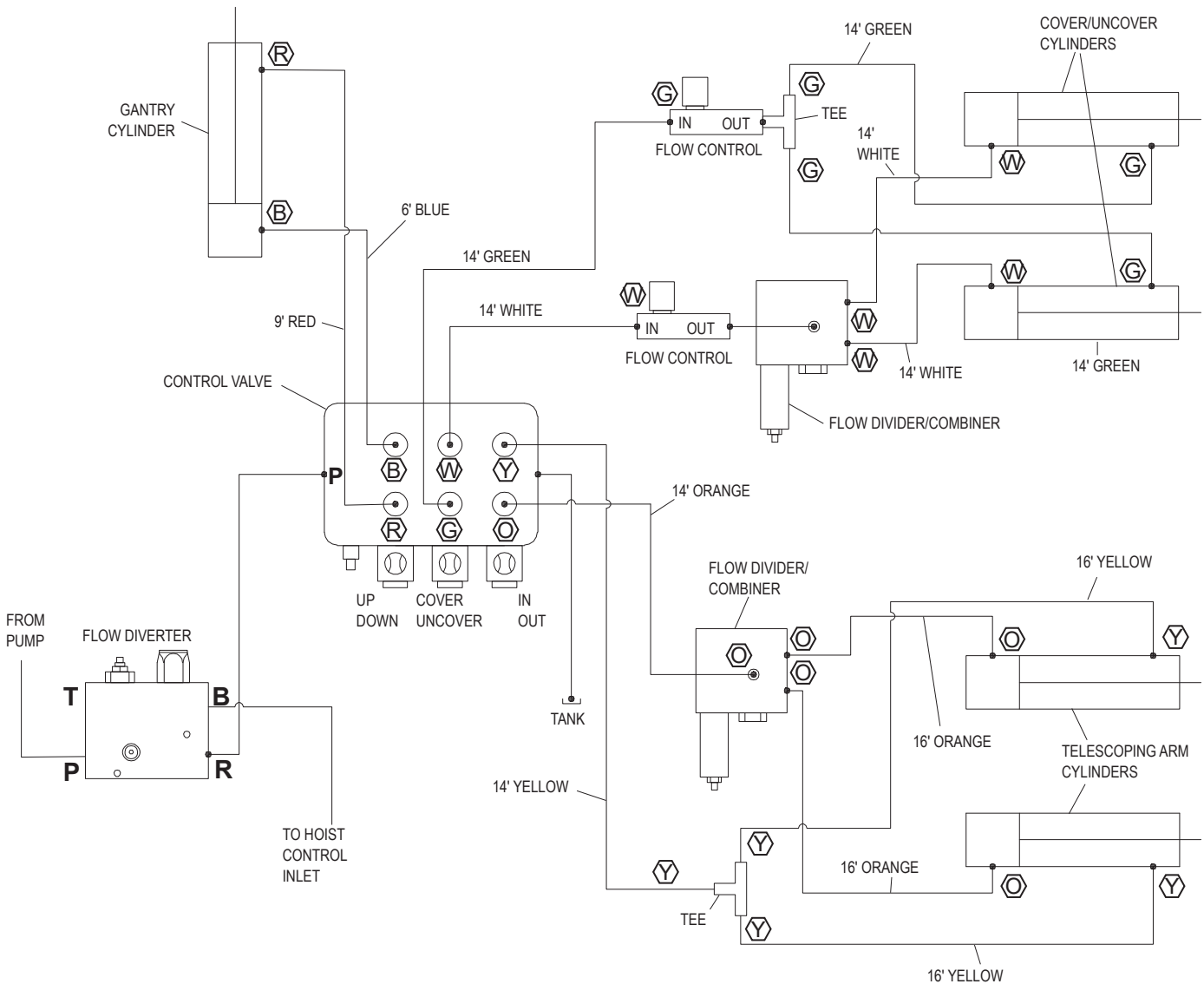

NOTE: Hoses for each hydraulic cylinder circuit color coded to facilitate routing hoses to correct locations. Map/diagram shows location and routing of each hose.

HOSE COLOR IDENTIFICATION

Item	Part #	Description	Qty.	Color
1.	1808932	1/4" x 6' Hose	1	Blue
2.	1808933	1/4" x 9' Hose	1	Red
3.	1808934	1/4" x 14' Hose	1	Orange
			1	Yellow
			3	White
			3	Green
4.	1808935	1/4" x 16' Hose	2	Yellow
			2	Orange

B	Blue
R	Red
O	Orange
Y	Yellow
W	White
G	Green

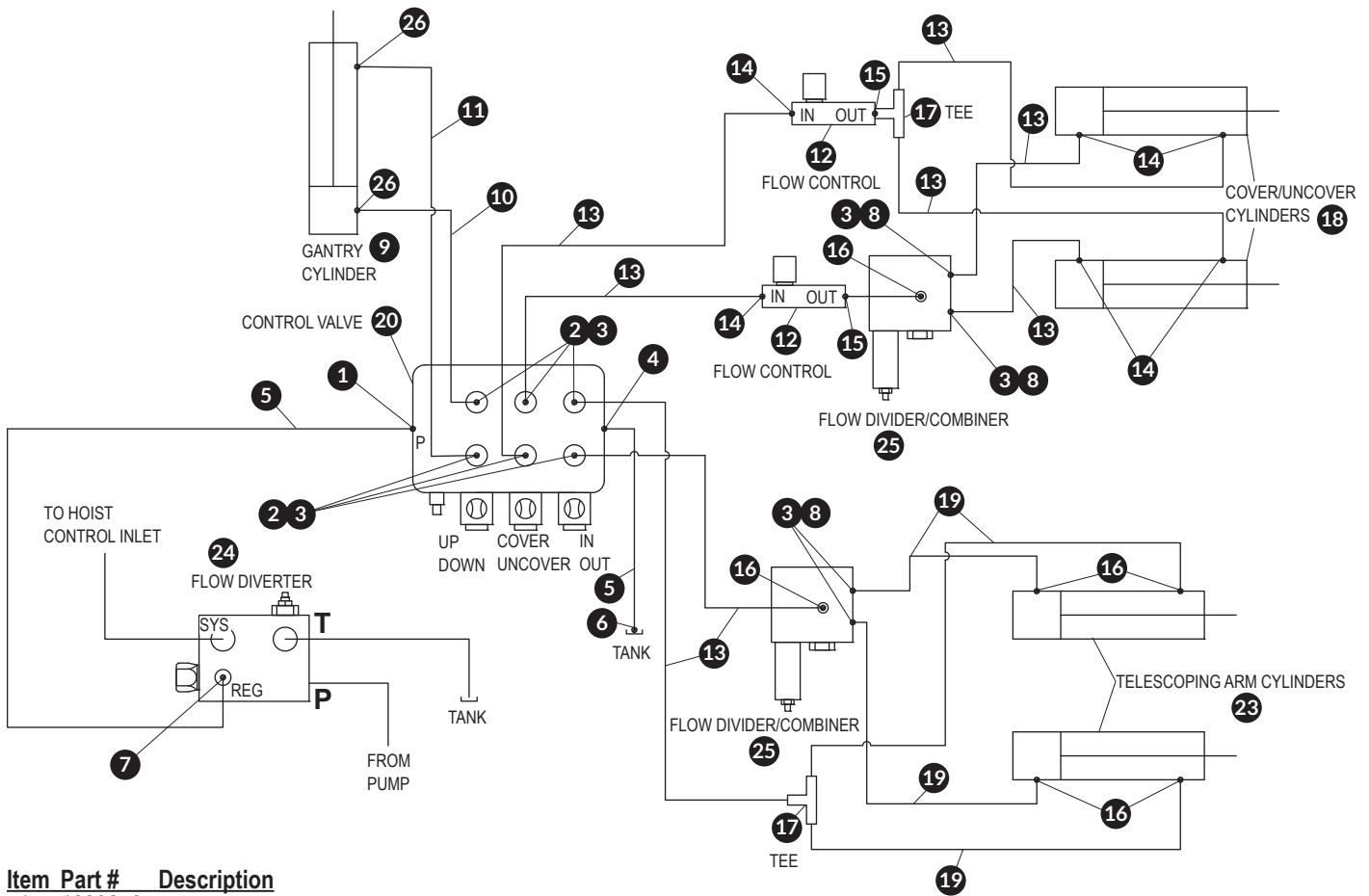

Item	Part #	Description	Quantity
1.	1809270	#8 SAE M x #8 JIC Adapter	1
2.	1809271	#8 SAE M x #6 JIC M Adapter	6
3.	1809278	#6 JIC M x #6 JIC F 90° Elbow	10
4.	1809272	#10 SAE M x #8 JIC M Adapter	1
5.	1808931	1/2" Hose x 8' - #8 JIC F One End	2
6.	1809273	1/2" NPT M x #8 JIC M Adapter	1
7.	1809274	#8 SAE M x #8 JIC M 90° Elbow	1
8.	1809183	#6 SAE M x #6 JIC M Adapter	4
9.	1808891	Gantry Cylinder - 36" Stroke	1
10.	1808932	1/4" Hose x 6' - #6 JIC F Both Ends	1
11.	1808933	1/4" Hose x 9' - #6 JIC F Both Ends	1
12.	1808928	1/4" Flow Control	2
13.	1808934	1/4" Hose x 14' - #6 JIC F One End	8
14.	1809276	1/4" NPT M x #6 JIC M Adapter	6
15.	1809279	1/4" NPT M x #6 JIC F Adapter	2
16.	1705725	#6 SAE M x #6 JIC M 90° Elbow	6
17.	1809280	#6 JIC M Tee	2
18.	1808890	Pivot Cylinder - 16" Stroke	2
19.	1808935	1/4" Hose x 16' - #6 JIC F One End	4
20.	1808929	Control Valve - 3 Spool	1
21.	1808937	#6 JIC F Reusable Fitting - 1/4" Hose	12
22.	1808938	#8 JIC F Reusable Fitting - 1/2" Hose	2
23.	1808892	Telescoping Arm Cylinder - 36" Stroke	2
24.	1809693	Flow Diverter 12LPM	1
25.	1808927	Flow Divider/Combiner	2
26.	1809277	3/8" NPT M x #6 JIC M 90° Elbow	2

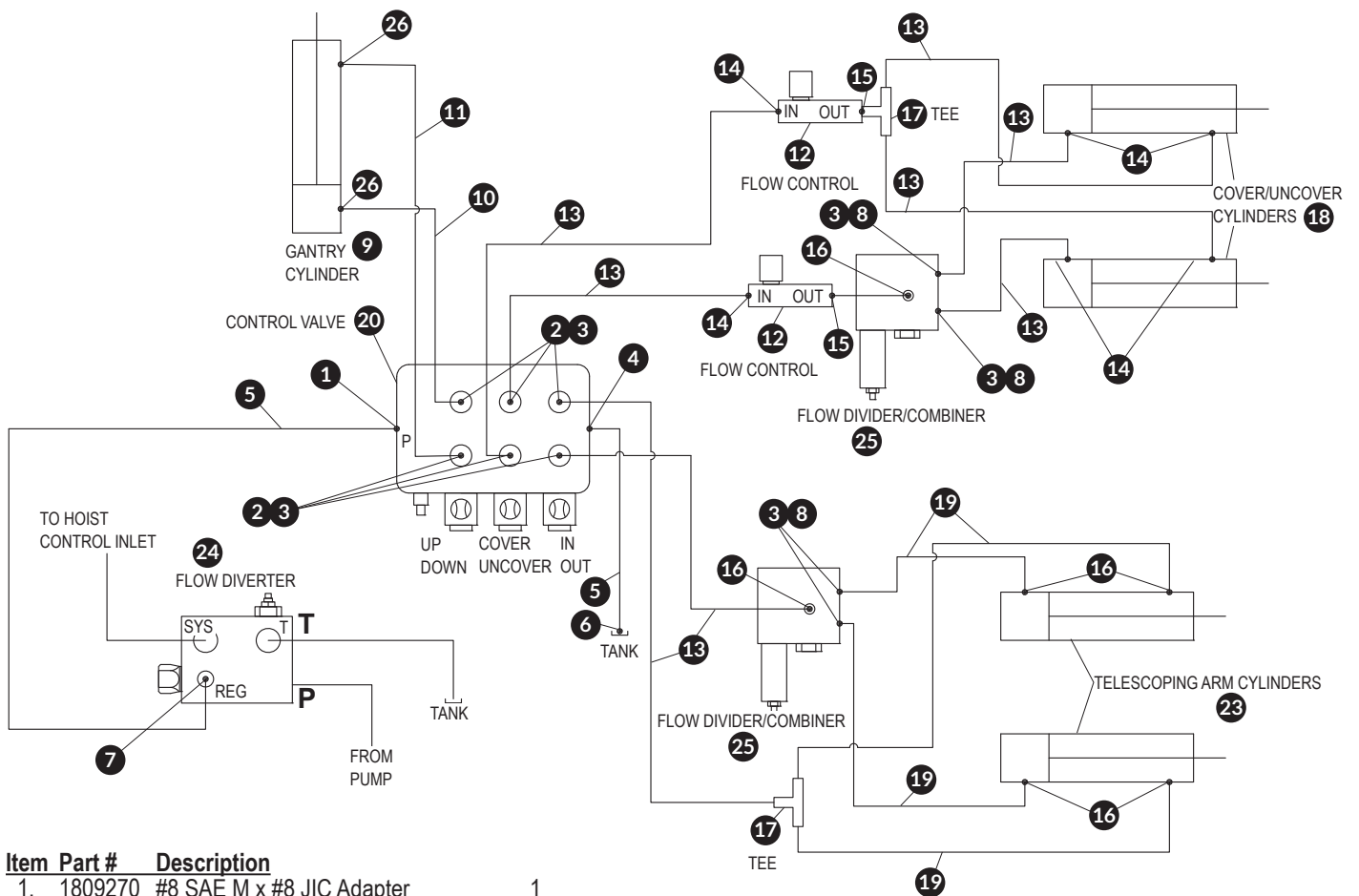

Item	Part #	Description	Quantity
1.	1809270	#8 SAE M x #8 JIC Adapter	1
2.	1809271	#8 SAE M x #6 JIC M Adapter	6
3.	1809278	#6 JIC M x #6 JIC F 90° Elbow	10
4.	1809272	#10 SAE M x #8 JIC M Adapter	1
5.	1808931	1/2" Hose x 8' - #8 JIC F One End	2
6.	1809273	1/2" NPT M x #8 JIC M Adapter	1
7.	1809274	#8 SAE M x #8 JIC M 90° Elbow	1
8.	1809183	#6 SAE M x #6 JIC M Adapter	4
9.	1808891	Gantry Cylinder - 36" Stroke	1
10.	1808932	1/4" Hose x 6' - #6 JIC F Both Ends	1
11.	1808933	1/4" Hose x 9' - #6 JIC F Both Ends	1
12.	1808928	1/4" Flow Control	2
13.	1808934	1/4" Hose x 14' - #6 JIC F One End	8
14.	1809276	1/4" NPT M x #6 JIC M Adapter	6
15.	1809279	1/4" NPT M x #6 JIC F Adapter	2
16.	1705725	#6 SAE M x #6 JIC M 90° Elbow	6
17.	1809280	#6 JIC M Tee	2
18.	1808890	Pivot Cylinder - 16" Stroke	2
19.	1808935	1/4" Hose x 16' - #6 JIC F One End	4
20.	1808929	Control Valve - 3 Spool	1
21.	1808937	#6 JIC F Reusable Fitting - 1/4" Hose	12
22.	1808938	#8 JIC F Reusable Fitting - 1/2" Hose	2
23.	1808892	Telescoping Arm Cylinder - 36" Stroke	2
24.	1809789	Flow Diverter Above 3500 PSI	1
25.	1808927	Flow Divider/Combiner	2
26.	1809277	3/8" NPT M x #6 JIC M 90° Elbow	2

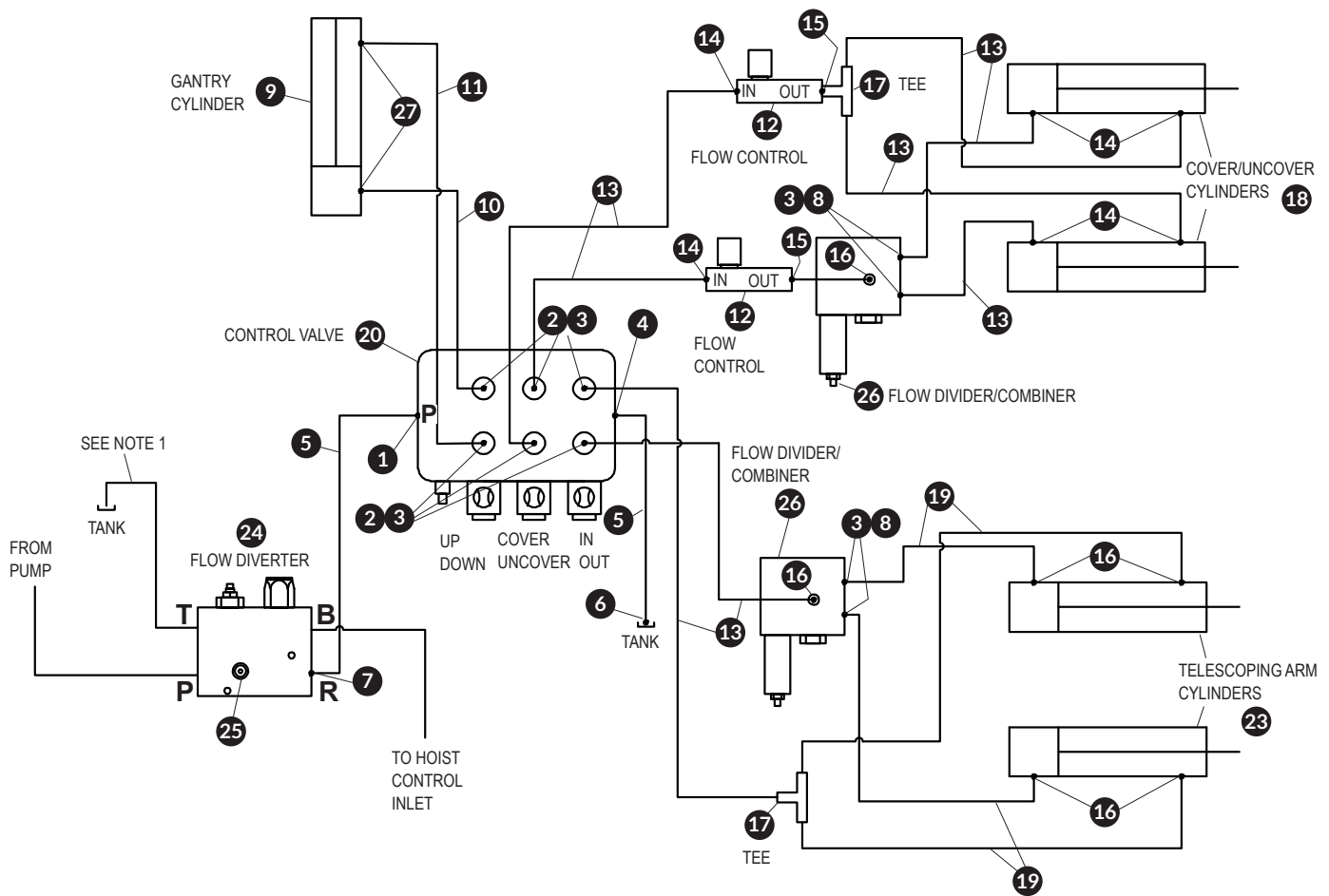

Item	Part #	Description	Quantity
1.	1809270	#8 SAE M x #8 JIC Adapter	1
2.	1809271	#8 SAE M x #6 JIC M Adapter	6
3.	1809278	#6 JIC M x #6 JIC F 90° Elbow	10
4.	1809272	#10 SAE M x #8 JIC M Adapter	1
5.	1808931	1/2" Hose x 8' - #8 JIC F One End	2
6.	1809273	1/2" NPT M x #8 JIC M Adapter	1
7.	1809274	#8 SAE M x #8 JIC M 90° Elbow	1
8.	1809183	#6 SAE M x #6 JIC M Adapter	4
9.	1808891	Gantry Cylinder - 36" Stroke	1
10.	1808932	1/4" Hose x 6' - #6 JIC F Both Ends	1
11.	1808933	1/4" Hose x 9' - #6 JIC F Both Ends	1
12.	1808928	1/4" Flow Control	2
13.	1808934	1/4" Hose x 14' - #6 JIC F One End	8
14.	1809276	1/4" NPT M x #6 JIC M Adapter	6
15.	1809279	1/4" NPT M x #6 JIC F Adapter	2
16.	1705725	#6 SAE M x #6 JIC M 90° Elbow	6
17.	1809280	#6 JIC M Tee	2
18.	1808890	Pivot Cylinder - 16" Stroke	2
19.	1808935	1/4" Hose x 16' - #6 JIC F One End	4
20.	1808929	Control Valve - 3 Spool	1
21.	1808937	#6 JIC F Reusable Fitting - 1/4" Hose	12
22.	1808938	#8 JIC F Reusable Fitting - 1/2" Hose	2
23.	1808892	Telescoping Arm Cylinder - 36" Stroke	2
24.	1808930	Flow Diverter	1
25.	1809275	#4 SAE M Plug	1
26.	1808927	Flow Divider/Combiner	2
27.	1809277	3/8" NPT M x #6 JIC M 90° Elbow	2

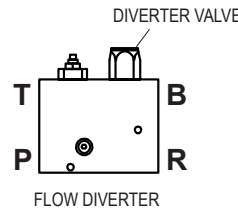

NOTE 1: Schematic shown with recommended PRV return line back to tank. PRV return back to tank must be used for applications where flow rates greater than 30 GPM exist and is optional for lesser flow rates. Refer to note 2 for conversion instructions.

NOTE 2: Flow diverter manifold is supplied with T port plugged (no return line to tank) and an internal plug (#4 SAE M) packaged separately. For maximum system protection, it is recommended that PRV return line to tank be utilized. For applications where flow rates greater than 30 GPM exist, PRV return line to tank must be installed. To install PRV return line back to tank:

1. Remove diverter valve.
2. Install internal plug (#4 SAE M) through B (bypass flow) port.
3. Remove T port plug and replace with #16 SAE adapter.
4. Reinstall diverter valve.

NOTE: If using tarper with high-pressure hydraulic hoist, use this schematic to install flow diverter.

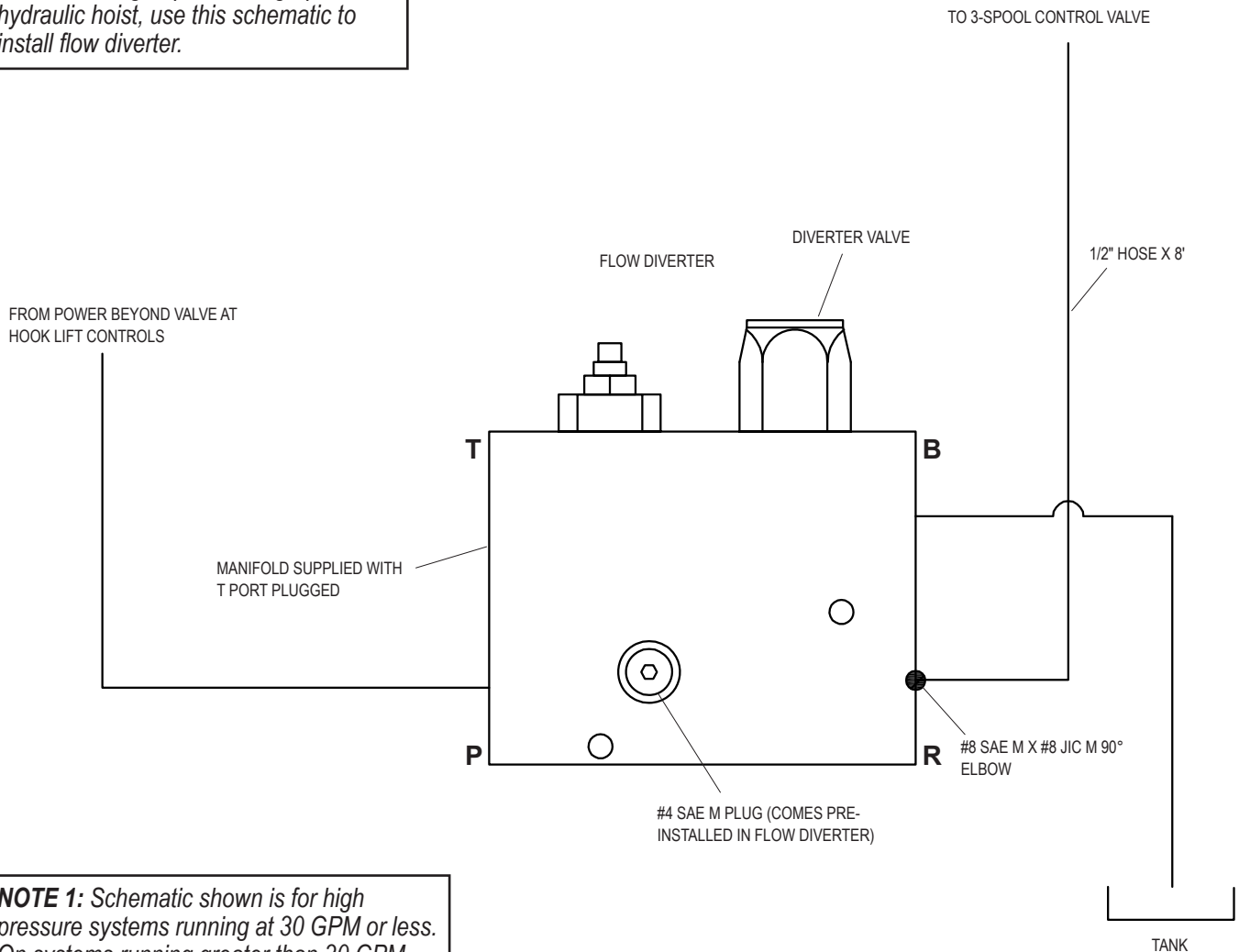

NOTE 1: Schematic shown is for high pressure systems running at 30 GPM or less. On systems running greater than 30 GPM, run two return lines to the tank, one return from the T port and one return from the B port. For this arrangement, an internal plug must be installed in the diverter. See note 2 for the internal plug installation procedure.

NOTE 2: Flow diverter manifold is supplied with T port plugged (no return line to tank), and an internal plug (#4 SAE M) packaged separately. For maximum system protection, it is recommended that the PRV return line to tank be utilized. For applications where flow rates greater than 30 GPM exist, PRV return line to tank must be installed. To install PRV return line back to the tank:

1. Remove diverter valve.
2. Install internal plug (#4 SAE M) through B (bypass flow) port.
3. Remove T port plug and replace with #16 SAE adapter.
4. Reinstall diverter valve.

NOTE: Hydraulic schematic is included in kit for reference.

- Filtration of 30 microns or better must be used with components.
- Only use pipe dope (such as Rectorseal®) on pipe threads.
- Do not overtighten fittings and do not use Teflon® tape.
- If flow rate is greater than 30 GPM, return line to tank from diverter relief valve must be used. Refer to hydraulic schematic for more detailed instructions. Failure to comply will void warranty.

STEP 1: Follow schematic to install flow diverter valve into pressure line running from pump to hoist controls. Inlets to flow diverter and outlet from flow diverter are #16 SAE. Kit includes two 1/2" hydraulic hoses with reusable fittings and adapters. Hoses connect to priority side of flow diverter to inlet side of cover control valve and create return line from cover control valve to tank. Flow diverter can be hard plumbed directly to pump or hoist valve or can be mounted remotely.

NOTE: For high-pressure hook-lift type systems, flow diverter must be mounted downstream from hoist controls. See instructions included with diverter valve.

STEP 2: Mount cover control valve on gantry mounting plate or in suitable location that allows for ease of operation while not interfering with hoist, hoist controls or container. Do not mount in area where moving parts could contact operator.

STEP 3: Follow hydraulic schematic to install fittings into cylinders (if not already installed), flow divider/combiners, flow controls and cover control valve.

NOTE: Do not use Teflon® tape on pipe threads. Only use pipe dope.

NOTE: All hoses furnished with system, except gantry cylinder hoses, are supplied with one reusable end to allow custom fitting hoses for installation. Reusable ends will be installed after hose installation. If hoses are cut, blow them out with compressed air to remove filings, shavings or particles that could contaminate system.

STEP 4: Install 6' hose and 9' hose between gantry cylinder and up/down function on cover control valve as shown in schematic. Hoses are supplied with fittings on both ends.

STEP 5: Install four 1/4" x 14' hoses onto cover control valve as shown in schematic (two hoses for cover/uncover and two hoses for in/out). Run hoses down chassis/frame toward rear of truck and secure with wire ties. Mark/identify each hose. Mount flow divider/combiners in area where these hoses end.

NOTE: Fittings and lengths of hoses are critical as differences can affect synchronization. For example, hoses running from flow divider/combiner to base ends of cylinders must be equal in length and use same fittings. Base end ports of cylinders must be connected to flow divider/combiners, and rod end ports must be connected to tees.

⚠ CAUTION

If hoses are routed incorrectly, system will not operate properly and could pose a potential safety hazard.

STEP 6: For cover/uncover function only, connect flow controls to flow divider combiner valve and tee used to control cover/uncover function with fittings provided. Use hydraulic schematic as reference.

NOTE: Adjustment knob is offset toward inlet side of each flow control. There is also an arrow stamped in each flow control pointing toward inlet side.

STEP 7: Install flow divider/combiners in suitable place on chassis/frame, placed as close as possible to pivot assemblies (front to rear location). Mount to non-moving hoist cross member (sub frame) or to plate attached to chassis cross member. Fasten with 1/4" fasteners (not provided). Install reusable fittings on four 1/4" hoses and connect to flow divider/combiners and tees per hydraulic schematic. Do not cross lines.

NOTE: Hoses are assembled to telescoping arm cylinders at factory.

STEP 8: Identify and mark base end and rod end hoses connected to arm extension cylinders. Do not cross lines. Slide loose ends of hoses through plastic swivel/pivot hose guides, and route hoses toward flow divider/combiners and tees. Install reusable ends and connect to flow divider/combiner and tee used in in/out function as shown in schematic.

STEP 9: Connect four remaining 1/4" x 14' hoses to 16" stroke cylinders used in cover/uncover function and route toward flow divider/combiners and tees. Install reusable ends and connect to flow divider/combiner and tee used in cover/uncover function as shown in schematic.

STEP 10: Verify connections and hose routings comply with schematic. Connect hoses to each other or stationary objects along hose paths. If chafe points are identified, slip large piece of hose or chafe guard over hose(s) at these points and secure.

NOTE: Using pressure gauge, set pressure relief valve on flow diverter to 100psi higher than hoist relief. Example: If hoist relief is set at 1600psi, set flow diverter to 1700psi. Determining hoist relief pressure can be done by “de-heading” hoist tilt frame cylinders in DOWN position. You may need to adjust pressure relief valve on hoist control to a higher pressure to allow relief in diverter to function properly. If this is done, make sure to re-set pressure relief valve on hoist control to the manufacturer’s specifications.

NOTE: Before bleeding system, if arm extension cylinders need to be connected to upper arms, use valve to operate/extend cylinders so cylinders can be fastened to upper arms.

STEP 11: Bleed system. Start truck and slowly engage PTO to activate hydraulic system. Operate cover/uncover valve to make arms move toward rear (cover). Only allow arms to move a few feet, then operate valve to move arms toward front (uncover). Move arms back and forth a few times to fill cylinders with oil.

⚠ CAUTION

Do not allow arms to move over center of truck until cylinders are filled with oil or arms will not be controllable during downward movement. This could cause damage or personal injury.

NOTE: If arms will not move upward from tarp roll base/rest, adjust pressure relief on cover control valve. Remove cap and turn adjusting screw 1/4 turn clockwise and try system again. Repeat until arms move smoothly and in unison.

NOTE: Crossover relief valve (built into flow divider/combiners) allows cylinders to resynchronize at end of stroke. All air must be removed from divider/combiner in order for this valve to function correctly.

⚠ CAUTION

Before installing flow diverter and control valve into hydraulic system, verify with hoist manufacturer that warranty will not be affected.

BLEED AIR FROM SYSTEM

Option 1: After cover/uncover cylinders have been filled with oil, move arms to front of truck so roller is sitting in rest. Hold valve handle for a few seconds to force relief open. Crack open fittings at base end of cylinders to let any trapped air escape. Retighten fittings and run system so stabilizer bar is resting on top rear of container. If container is not available, rest stabilize bar on forks of forklift to simulate container. Hold valve for a few seconds to force relief to open. Crack open fitting at rod end of cylinders to let any trapped air escape. Retighten fittings and repeat this process until all air is removed from cylinders, hoses and valves.

Option 2: Move arms to rest position at front of truck. Disconnect cylinders from rack gear by removing set screw and pin connecting cylinder to rack gear. Prop cylinders up, then fully extend cylinders. Hold valve handle for a few seconds to force relief to open. Crack open fittings at rod end of cylinders to let any trapped air escape. Retighten fittings and fully retract cylinders. Hold valve handle for a few seconds to force relief open. Crack open fittings at base end of cylinders. Repeat process until all air is removed from cylinders, hoses and valves. Reconnect cylinders to rack gears by reinstalling pin and set screws. Apply thread locker to set screws when reassembling.

NOTE: Make sure tarp closes/covers when valve handle is moved to COVER position on control valve. If tarp uncovers/moves to front instead, hoses need to be reversed.

STEP 12: Bleed air from gantry cylinder in same manner as for cover/uncover cylinders. Lift arms and roller off tarp roll base/rest before moving gantry. Operate gantry up and down to verify gantry is operating correctly. Gantry should move up when valve handle is moved to UP position on control valve. Correct if needed.

STEP 13: Bleed air from telescopic arm cylinders in same manner as for cover/uncover cylinders. Hold valve handle at both ends of cylinder stroke for a few seconds to force relief valve to open and resynchronize cylinders. Operate arms in and out to verify arms are operating correctly. If arm extensions do not move in and out, adjust pressure relief on cover control valve as shown for cover/uncover cylinders. Check to make sure arms move out when valve handle is moved to OUT position on control valve. Correct as needed.

NOTE: *In order for system to operate correctly, all air must be bled from lines and cylinders.*

STEP 14: Adjust flow controls so arms move at speed needed to cover or uncover container in 15 to 20 seconds. Flow controls meter flow in reverse direction which means, when covering, flow control connected to tee is controlling speed and, when uncovering, flow control connected to flow divider/combiner is controlling speed. Adjust flow controls by turning adjusting knob. Turn clockwise to slow down speed and turn counter-clockwise to reduce speed. Once speed is set to move arms from front to back or back to front in 15 to 20 seconds, lock adjustment knob in place by tightening set screw on side of knob. Flow controls should not need to be touched after original setting.

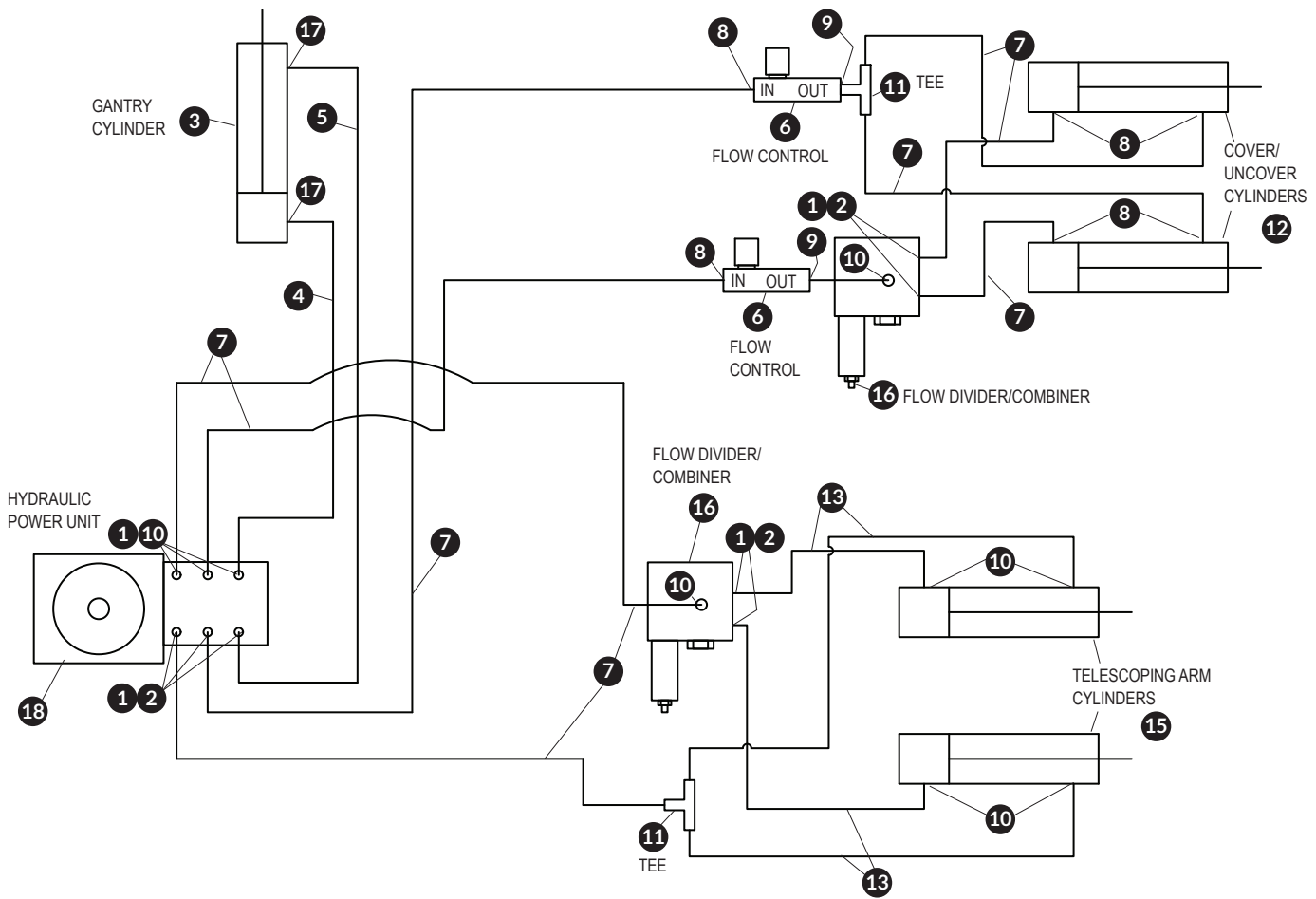

Item	Part #	Description	Quantity
1.	1809278	#6 JIC M x #6 JIC F 90° Elbow	10
2.	1809183	#6 SAE M x #6 JIC M Adapter	7
3.	1808891	Gantry Cylinder - 36" Stroke	1
4.	1808932	1/4" Hose x 6' - #6 JIC F Both Ends	1
5.	1808933	1/4" Hose x 9' - #6 JIC F Both Ends	1
6.	1808928	1/4" Flow Control	1
7.	1808934	1/4" Hose x 14' - #6 JIC F One End	8
8.	1809276	1/4" NPT M x #6 JIC M Adapter	6
9.	1809279	1/4" NPT M x #6 JIC F Adapter	2
10.	1705725	#6 SAE M x #6 JIC M 90° Elbow	9
11.	1809280	#6 JIC M Tee	2
12.	1808890	Pivot Cylinder - 16" Stroke	2
13.	1808935	1/4" Hose x 16' - #6 JIC F One End	4
14.	1808937	#6 JIC F Reusable Fitting - 1/4" Hose	12
15.	1808892	Telescoping Arm Cylinder - 36" Stroke	2
16.	1808927	Flow Divider/Combiner	2
17.	1809277	3/8" NPT M x #6 JIC M 90° Elbow	2
18.	1809185	Hydraulic Power Unit - 12V	1

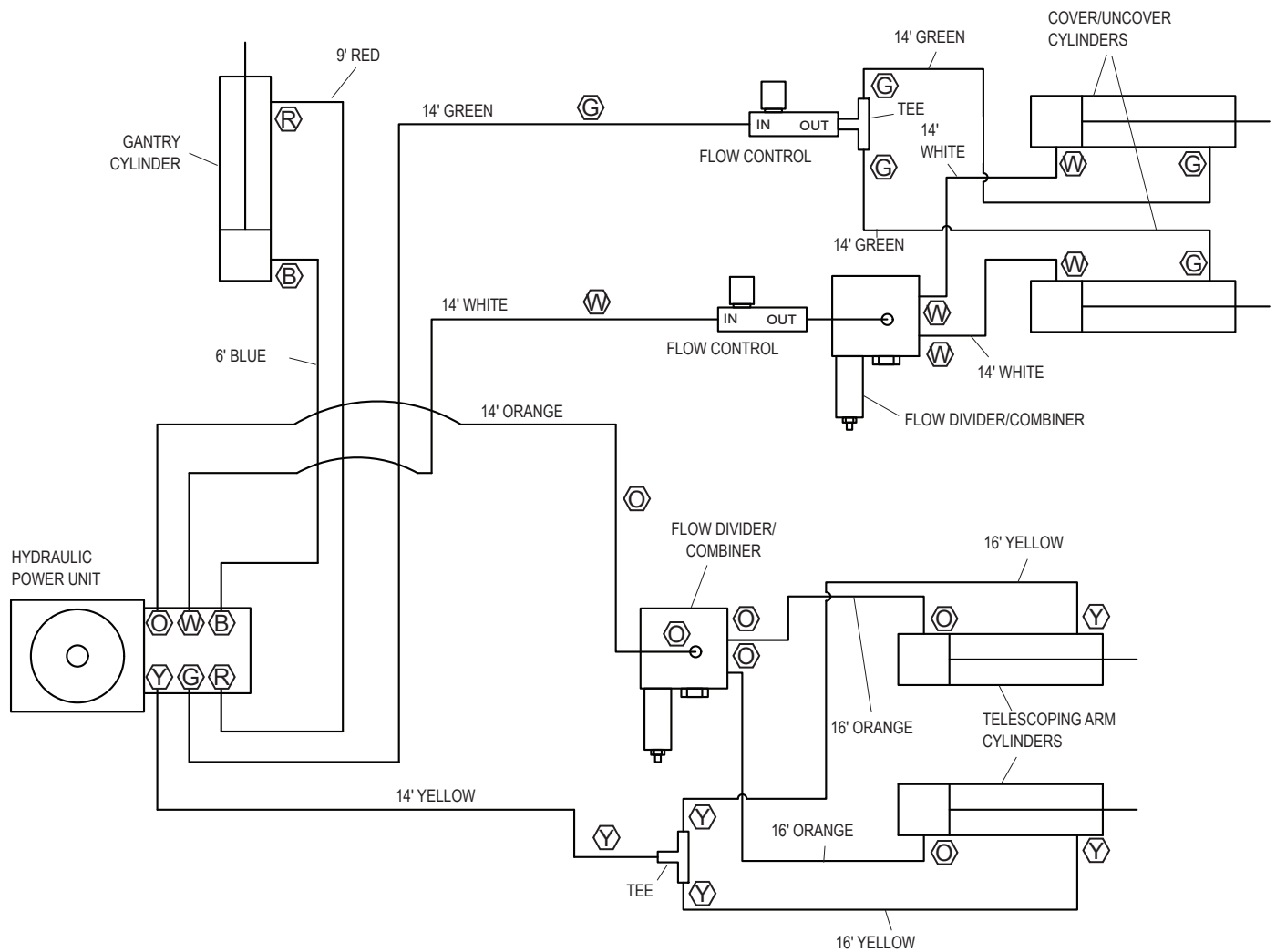

NOTE: Hoses for each hydraulic cylinder circuit color coded to facilitate routing hoses to correct locations. Map/diagram shows location and routing of each hose.

HOSE COLOR IDENTIFICATION

Item	Part #	Description	Qty.	Color
1.	1808932	1/4" x 6' Hose	1	Blue
2.	1808933	1/4" x 9' Hose	1	Red
3.	1808934	1/4" x 14' Hose	1	Orange
			1	Yellow
			3	White
			3	Green
4.	1808935	1/4" x 16' Hose	2	Yellow
			2	Orange

B	Blue
R	Red
O	Orange
Y	Yellow
W	White
G	Green

Item Part # Description

- 1. 1809479 Upper Rear Panel Assembly
- 2. 1809481 Lower Rear Panel Assembly
- 3. 1809185 12V Hydraulic Pump w/Valves
- 4. 1809184 3-Toggle Control Box w/126" Lead
- 5. 1809399 12V Wireless Module w/Remote
- 6. 1809480 Upper Rear Panel
- 7. 1809482 Lower Rear Panel
- 8. 1809485 Housing Support Leg
- 9. 1809477 Outer Pump Mounting Bracket
- 10. 1809478 Inner Pump Mounting Bracket
- 11. 1809489 Front Cover Panel
- 12. 1809490 Top Cover Panel
- 13. 1809488 Toggle Control Mounting Bracket
- 14. 1809183 #6 SAE M x #6 JIC M Adapter
- 15. 1809278 #6 JIC M x #6 JIC M 90° Elbow
- 16. 1705725 #6 SAE M x #6 JIC M 90° Elbow
- 17. 1809494 1/0 Cable x 17' - Red
- 18. 1809495 1/0 Cable x 17' - Black
- 19. 1809496 Breaker Lead Wire
- 20. 1809466 Circuit Breaker - 225A Manual Reset
- 21. 1809460 Cable Eyelet - 1/0 AWG x 3/8" Stud
- 22. 1809464 Heat Shrink - 3/4" ID - Red
- 23. 1809465 Heat Shrink - 3/4" ID - Black
- 24. 1705072 Quick Connect - 18 Ga. x 1/4" Male
- 25. 1705073 Quick Connect - 18 Ga. x 1/4" Female
- 26. 1705800 Ring Terminal - 18 Ga. x 5/16" Stud
- A. 1809472 Self Tapping Screw - #10 x 1/2X"
- B. 1704906 Carriage Bolt - 1/4" x 1/2"
- C. 1700381 Cap Screw - 1/4" x 1"
- E. 1809469 Hex Flange Cap Screw - 5/16" x 1"
- F. 1701208 Cap Screw - 5/16" x 1-1/4"
- J. 1809468 Hex Flange Cap Screw - 3/8" x 1"
- Q. 1701543 Nylock Nut - 1/4"
- S. 1700419 Nylock Nut - 5/16"
- T. 1700411 Hex Nut - 5/16"
- V. 1809471 Jam Nut - 5/16"
- AA. 1704912 Lock Washer - 5/16"
- GG. 1809470 Stud - 5/16" x 1-3/4"

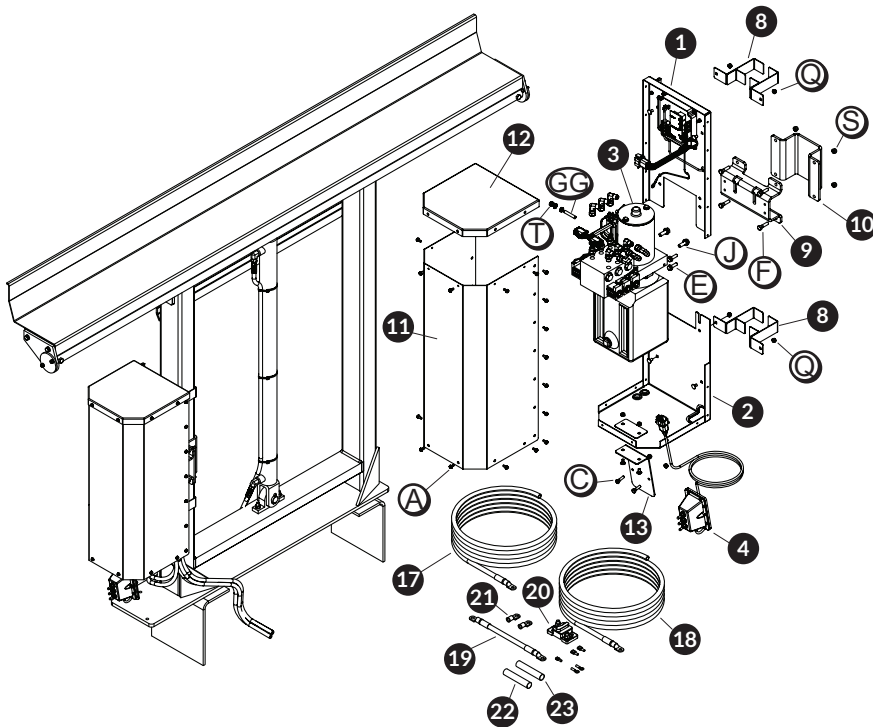

STEP 1: Determine side of gantry where hydraulic pump unit will be located. For driver side installation, mounting plate is pre-welded to driver side leg of gantry. If passenger side mounting is desired, locate and weld included mounting plate to passenger side gantry leg at dimension shown. Plate must be centered on leg.

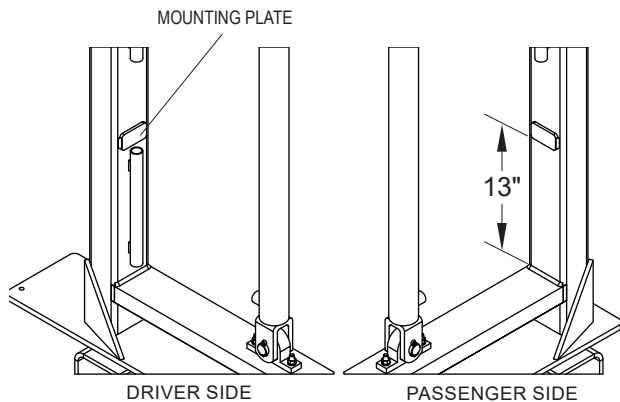

NOTE: Driver side mounting will be shown for remaining installation steps.

STEP 2: Install pump mounting brackets. Slide brackets over chosen gantry legs as shown and secure in place with bolts and nylock nuts. Inner pump mounting bracket should be resting on top of mounting plate.

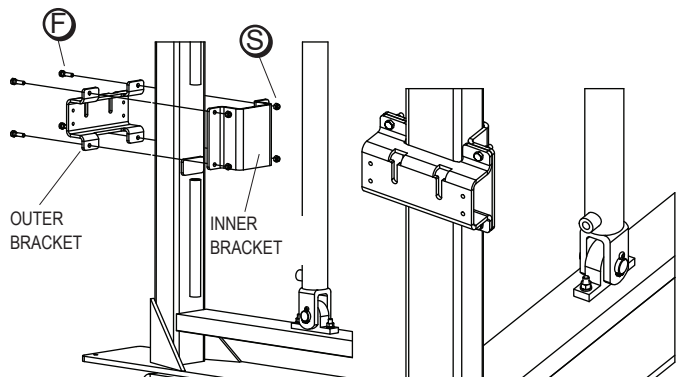

STEP 3: Install hydraulic pump unit to mounting brackets. Apply threadlocking compound to each 3/8" x 1" flange head hex screws before threading into backside of pump. Partially thread screws in until there is an approximately 3/8" gap between screw head and pump mounting block. With screws in place, carefully lift pump unit assembly up to mounting brackets. Carefully slide screw heads down through notches in mounting bracket so pump will hang in place. Using wrench or ratcheting wrench, fully tighten screws and secure pump assembly to the mounting bracket.

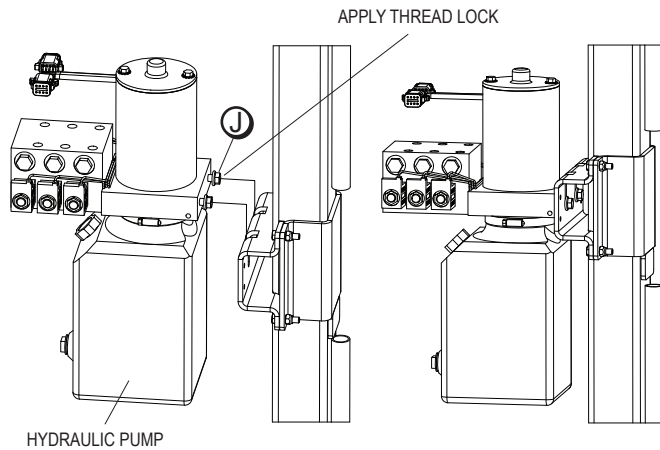

STEP 4: Remove packing material from upper rear panel assembly, being careful not to cut or damage any wires or the wireless control unit. Check location of antenna mounted to backside of upper rear panel. Antenna comes preinstalled for pump units mounted on driver side. If mounting on passenger side gantry leg, move antenna to other side of panel as shown.

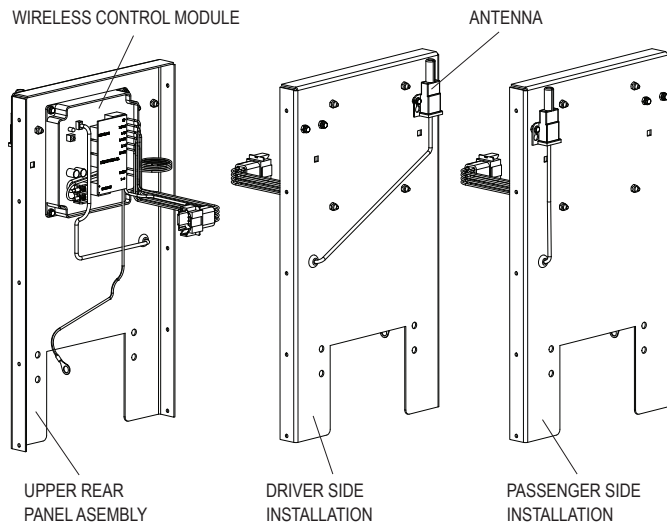

STEP 5: Slide upper rear panel assembly over pump mounting block. Apply threadlocker and loosely install two 5/16" x 1" hex flange screws through holes in upper panel and into mounting bracket. Slide lower panel up behind pump reservoir and in front of upper panel. Use slots in lower panel to slide lower panel over upper panel and under screw heads. Apply threadlocker and install two more 5/16" x 1" hex flange screws through remaining holes in both panels before tightening all four screws securely. Install 5/16" nylock nuts on all four screws and tighten securely.

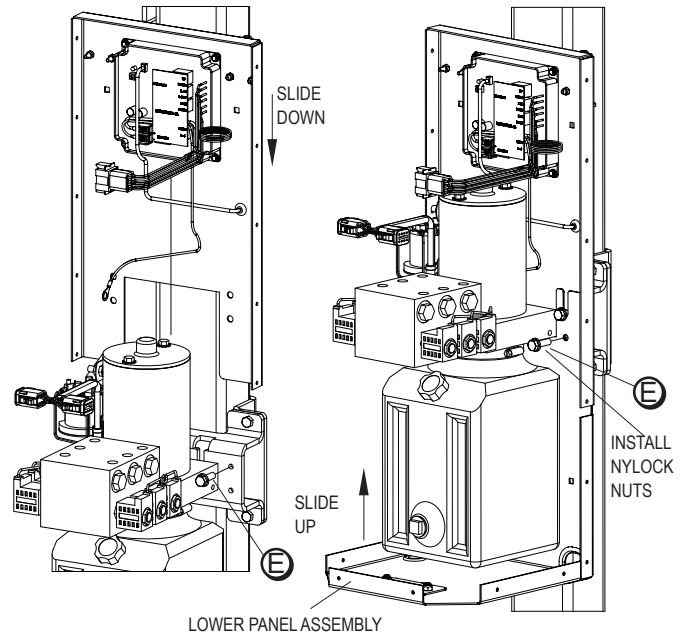

STEP 6: Install standoff legs to rear panels of pump housing. Slide four standoff legs over gantry leg and secure to rear panel using bolts and lock nuts, being careful not to pinch antenna wire.

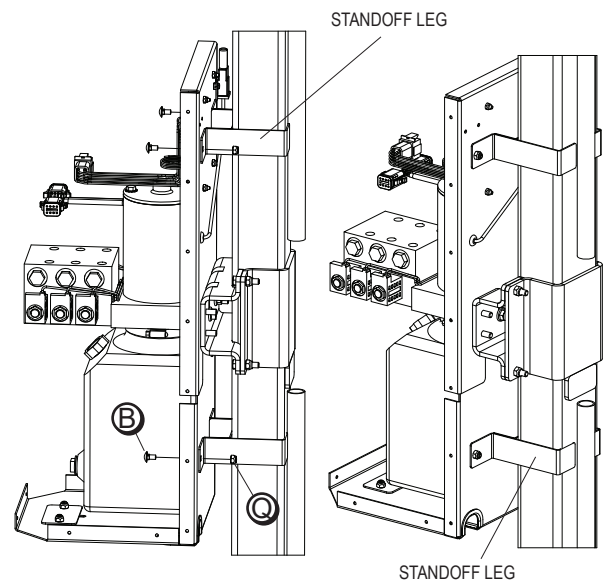

STEP 1: Follow hydraulic schematic to install fittings into cylinders (if not already installed), flow divider/combiners, flow controls, and 12V hydraulic pump.

NOTE: Do not use Teflon® tape on pipe threads. Only use pipe dope.

NOTE: All hoses furnished with system, except gantry cylinder hoses, are supplied with one reusable end to allow custom fitting hoses for installation. Reusable ends will be installed after hose installation. If hoses are cut, blow out with compressed air to remove filings, shavings or particles that could contaminate system.

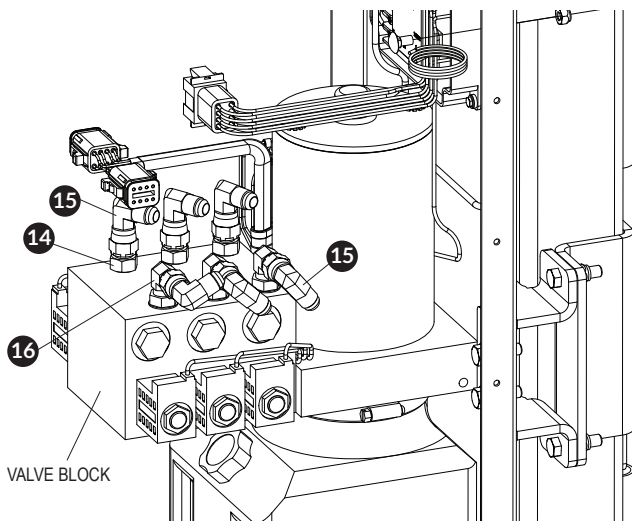

Tip: To simplify hose routing into pump enclosure, angle hydraulic fittings approximately as shown on hydraulic pump valve block. Final adjustments can be made as hoses are installed.

STEP 2: Install and route 6' hose and 9' hose on gantry cylinder as shown in hydraulic schematic, and route to pump enclosure (will be installed in the next step). Hoses are supplied with fittings on each end.

STEP 3: Route 6', 9' and four 1/4" x 14' hoses through access hole in lower pump enclosure and onto hydraulic pump fittings using hydraulic schematic and hose color coding schematic.

Tip: Install hoses on right side of pump valve block first before installing remaining hoses on left side of valve block. Check to be sure all fittings and hose connections are tightened properly.

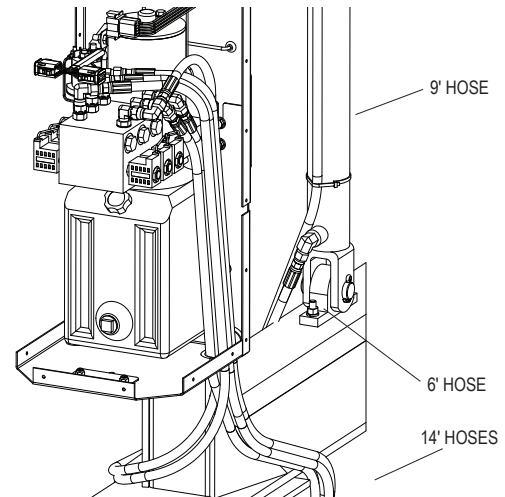

STEP 4: Run four 14' hoses from pump down chassis/frame toward rear of truck and secure with wire ties. Mark/identify each hose. Mount flow divider/combiners in area where hoses end.

NOTE: Fittings and lengths of hoses are critical as differences can affect synchronization. For example, hoses running from flow divider/combiner to base ends of cylinders must be equal in length and use same fittings. Base end ports of cylinders must be connected to flow divider/combiners, and rod end ports must be connected to tees.

⚠ CAUTION

If hoses are routed incorrectly, system will not operate properly and could pose a potential safety hazard.

STEP 5: For cover/uncover function only, connect flow controls to flow divider combiner valve and tee used to control cover/uncover function with fittings provided. Use hydraulic schematic as reference.

NOTE: Adjustment knob is offset toward inlet side of each flow control. An arrow is stamped in each flow control pointing toward inlet side.

STEP 7: Install flow divider/combiners in suitable place on chassis/frame, placed as close as possible to pivot assemblies (front to rear location). Mount to non-moving hoist crossmember (subframe) or to plate attached to chassis crossmember. Fasten with 1/4" fasteners (not provided). Install reusable fittings on four 1/4" hoses and connect to flow divider/combiners and tees per hydraulic schematic. Do not cross lines.

NOTE: Hoses are assembled to telescoping arm cylinders at factory.

STEP 8: Identify and mark base end and rod end hoses connected to arm extension cylinders. Do not cross lines. Slide loose ends of hoses through plastic swivel/pivot hose guides, and route hoses toward flow divider/combiners and tees. Install reusable ends and connect to flow divider/combiner and tee used in in/out function as shown in schematic.

STEP 9: Connect four remaining 1/4" x 14' hoses to 16" stroke cylinders used in cover/uncover function and route toward flow divider/combiners and tees. Install reusable ends and connect to flow divider/combiner and tee used in cover/uncover function as shown in schematic.

STEP 10: Verify connections and hose routings comply with schematic. Connect hoses to each other or stationary objects along hose paths. If chafe points are identified, slip large piece of hose or chafe guard over hose(s) at these points and secure.

STEP 1: Starting at pump, install 5/16" x 1-3/4" threaded stud into threaded hole until it bottoms out in pump mounting block. Install 5/16" jam nut onto stud and tighten against block.

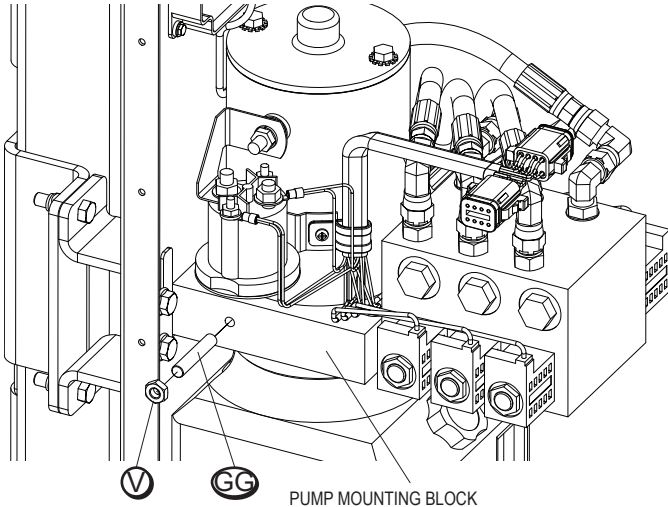

STEP 2: Route heavy-gauge black battery cable into pump enclosure. Slide end of black cable with factory installed 5/16" eyelet/ring terminal through rubber grommet at rear of lower enclosure panel as shown. Carefully pull cable up through grommet and up to stud installed in pump mounting block. Slide terminal/eyelet over stud and secure with star lock washer and 5/16" nut.

Tip: Use silicone spray inside grommet and on battery cables to aid in sliding cables through grommets.

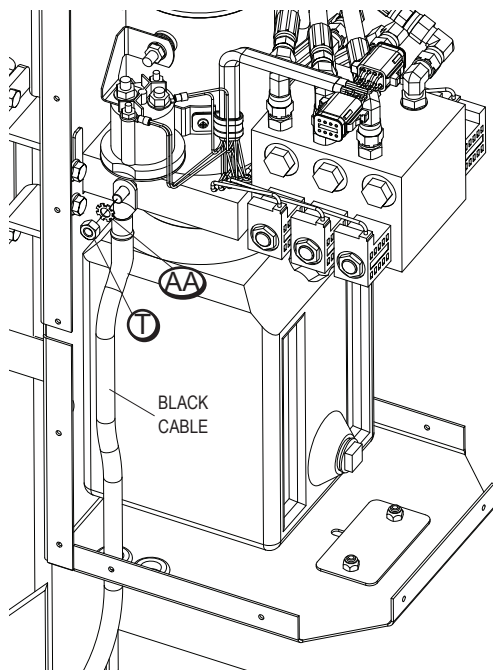

STEP 3: Route heavy-gauge red battery into pump-enclosure. Slide end of red cable with factory installed 5/16" eyelet/ring terminal through rubber grommet in lower enclosure panel as shown. Carefully pull cable up through grommet and up to stud on pump solenoid as shown. Install battery cable terminal/eyelet to solenoid stud. Be careful not to over torque nut when re-installing to solenoid stud.

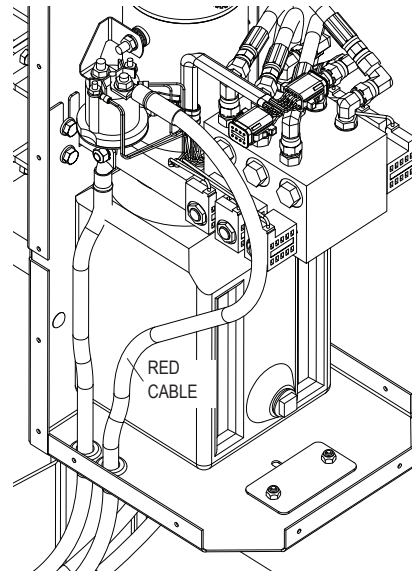

STEP 4: Route ground and positive cables from pump housing down along chassis/frame to battery box. Avoid any pinch points or areas where cables could be worn or damaged. Secure cables along route with cable ties.

Tip: With pump battery cables routed inside battery box, shorten to remove excess cable. Connect black cable to battery negative/ground post. Connect red cable to positive battery post through provided manual reset circuit breaker. In 12V systems with two batteries connected in parallel, preferred connection method is to connect black cable to negative post of one battery and red wire to positive post of other battery. If desired, connect both cables can be connected to same battery and batteries will equalize. Following steps detail process for making these connections.

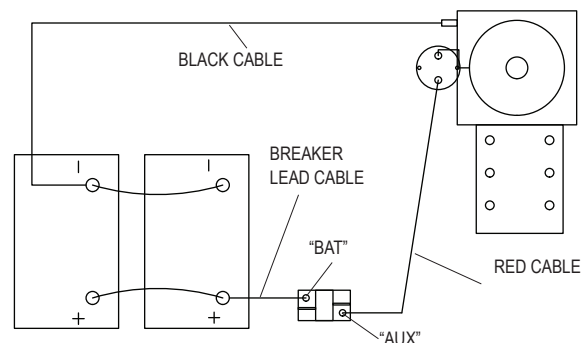

STEP 5: Strip cable ends and install 3/8" ring terminals/eyelets. Using eyelets as guide, cut and remove approximately 5/8" of insulation from copper cable. Crimp eyelets onto copper cable. (Preferably done with manual or hydraulic crimping tool rated for 1/0 battery cable.) After installing eyelets, slide 2" length of included heat shrink tubing over connection and seal in place using heat gun.

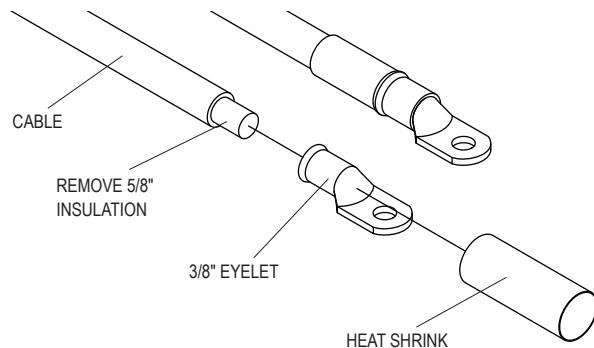

STEP 6: With terminals/eyelets installed, final connections can be made at battery using wiring diagram as reference. Connect black battery cable to battery negative/ground post. Connect provided 12" breaker lead cable to circuit breaker post labeled "BAT", and connect red battery cable from pump to circuit breaker post labeled "AUX". With cables connected to circuit breaker, connect other end of breaker lead cable to positive battery post using heat gun.

NOTE: It is recommended to disconnect positive pump cable from battery until pump has been filled with fluid.



CAUTION

Running the pump unit dry will damage the pump.

NOTE: If LiteAll work lights are to be installed, wire at this point before final connections are made and pump is filled with fluid. Instructions for LiteAll™ installation are on page 30. Return to this page after installing work lights.

STEP 7: Install and connect 3-toggle control box.

Option 1: Mount toggle control box to bottom of pump enclosure. First remove panel cover plate from lower enclosure panel. Mount control box to mounting bracket using 1/4" bolts and nylock nuts. Route connector plug through hole in lower panel before installing box and mounting bracket to lower panel with 1/4" carriage screws and nylock nuts. Lead wire from control box to connector plug should be routed through slot in lower panel so not pinched or damaged.

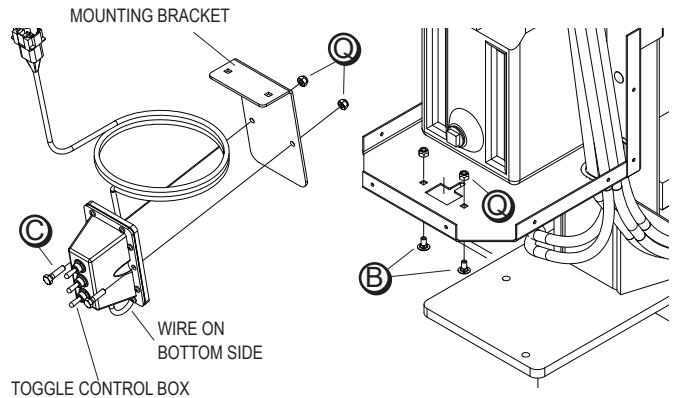

NOTE: Control box must be mounted so wire coming out of box is pointing towards ground.

Connect plug from toggle switch box to one connector on pump unit. Excess switch wire can be wound into loop and placed underneath pump reservoir.

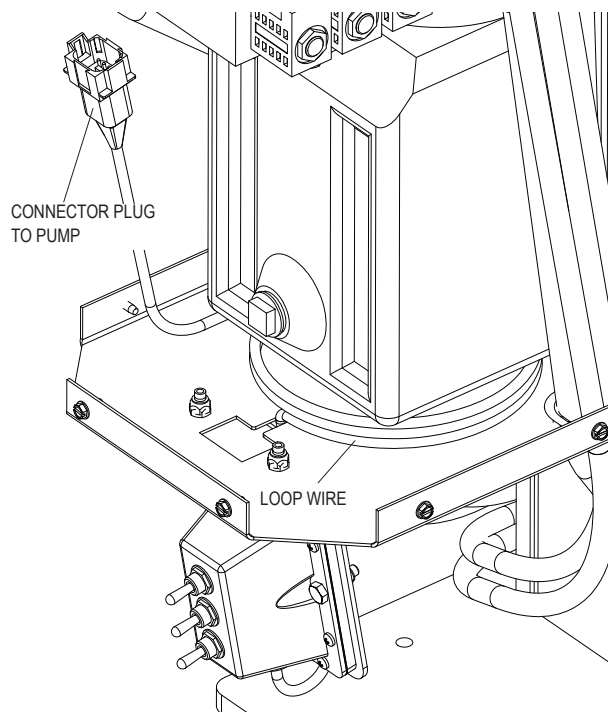

Option 2: Locate and install control box separate from pump enclosure. Find suitable mounting location within range of control box wire lead length. Bracket can be fastened or welded in place (fasteners not included). With bracket installed, install control box to mounting bracket with 1/4" bolts and nylock nuts.

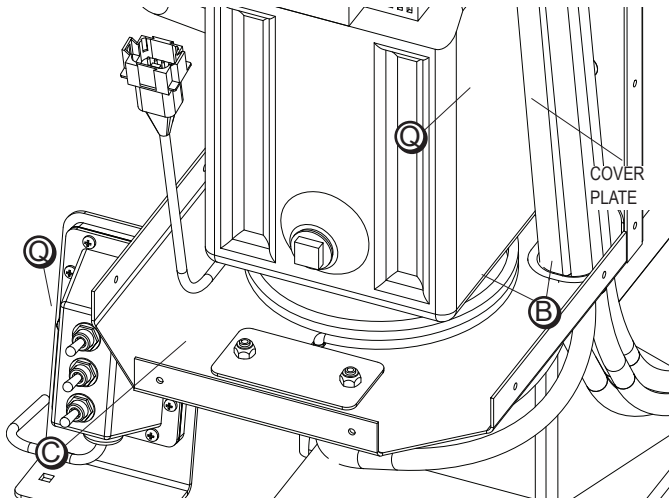

NOTE: Control box must be mounted so wire coming out of box is pointing towards ground.

Remove panel cover plate from lower enclosure panel. Route connector plug through hole in lower panel. Lead wire from control box to connector plug should be routed through slot in lower panel, and panel cover plate should be reinstalled making sure wire lead is in slot behind plate and being not pinched or damaged.

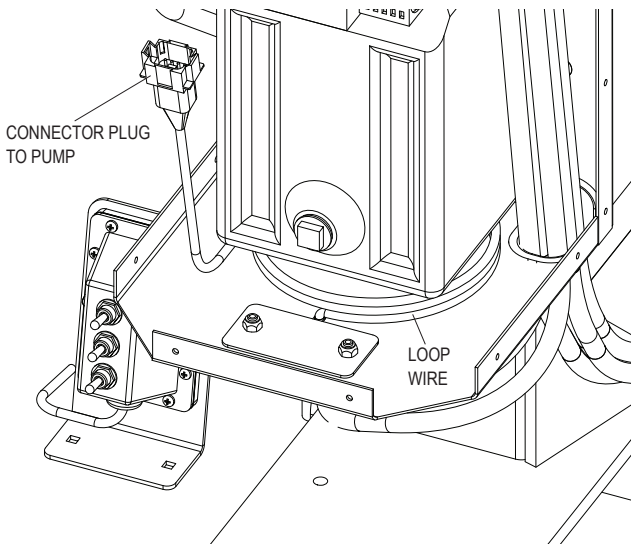

Connect plug from toggle switch box to connector on pump unit. Excess switch wire can be wound into loop and placed underneath pump reservoir.

STEP 8: Make connections for wireless control module. Route ground lead wire behind pump and down to grounding stud. Install ring terminal over grounding stud and secure in place. Connect harness plug from wireless unit to connector on pump unit.

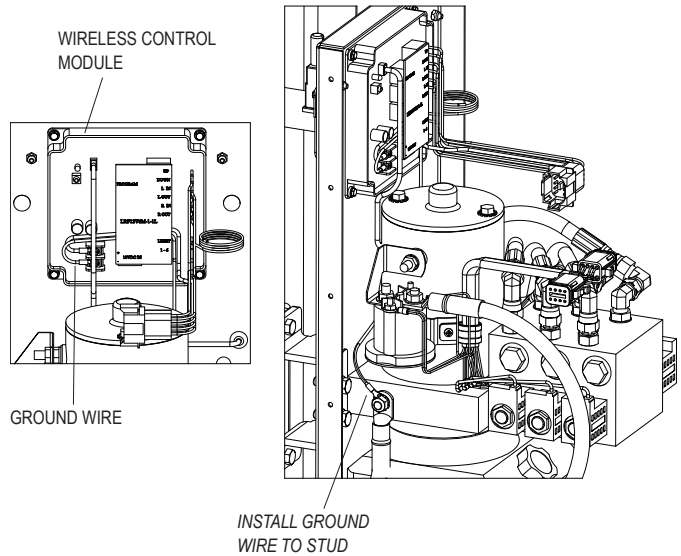

STEP 1: Hydraulic power unit is now ready to be filled with hydraulic fluid. Use Dexron automatic transmission fluid only. Use of other fluids may cause unit to fail. Remove red plug from reservoir. Plug will be replaced by breather cap temporarily held in place at bottom of reservoir. Using a funnel, add fluid to reservoir and fill to just under the fill hole. Approximately 11 quarts of hydraulic fluid will completely fill system and reservoir. Fluid will still need to be added in next step during the process of filling and bleeding system. Keep an eye on reservoir level doesn't get too low, allowing pump to suck air into system or possibly damage pump.

STEP 2: With reservoir filled with fluid, operate cover/uncover toggle switch to make arms move toward rear (cover). Only allow arms to move up a few feet, then operate switch to move arms toward front (uncover). Move arms back and forth a few times to fill cylinders with oil.

⚠ CAUTION

Do not allow arms to move over center of truck until cylinders are filled with oil or arms will not be controllable during downward movement. This could cause damage or personal injury.

BLEED AIR FROM SYSTEM

Option 1: After cover/uncover cylinders are filled with oil, move arms to front of truck so roller is at rest. Hold toggle switch for a few seconds to force relief open. Crack open fittings at base end of cylinders to let any trapped air escape. Retighten fittings and run system so stabilizer bar is resting on top rear of container. If container is not available, rest stabilize bar on forks of forklift to simulate container. Hold switch a few seconds to force relief to open. Crack open fitting at rod end of cylinders to let any trapped air escape. Retighten fittings and repeat this process until all air is removed from cylinders, hoses and valves.

Option 2: Move arms to rest position at front of truck. Disconnect cylinders from rack gear by removing set screw and pin connecting cylinder to rack gear. Prop cylinders up, then fully extend cylinders. Hold toggle switch for a few seconds to force relief to open. Crack open fittings at rod end of cylinders to let any trapped air escape. Retighten fittings and fully retract cylinders. Hold switch for a few seconds to force relief open. Crack open fittings at base end of cylinders. Repeat process until all air is removed from cylinders, hoses and valves. Reconnect cylinders to rack gears by reinstalling pin and set screws. Apply thread locker to set screws when reassembling.

NOTE: Make sure tarp closes/covers when wireless button for "cover" is pressed. If tarp uncovers/moves to front instead, hoses need to be reversed. See page 29 for remote functions and operation.

STEP 3: Bleed air from gantry cylinder in same manner as for cover/uncover cylinders. Lift arms and roller off tarp roll base/rest before moving gantry. Operate gantry up and down to verify gantry is operating correctly. Gantry should move up when wireless remote button for UP is pressed. Correct if needed. This is also a good time to apply grease/lubricant to gantry legs.

STEP 4: Bleed air from telescopic arm cylinders in same manner as for cover/uncover cylinders. Lift arms and roller off tarp roll base/rest so at an approximate 45 degree angle to truck chassis. Hold switch on at both ends of cylinder stroke a few seconds to force relief valve to open and synchronize cylinders. Operate arms in and out to verify arms are operating correctly and also to apply grease/lubricant to extension arms. Check to make sure arms move out/extend when wireless remote button for EXTEND is pressed. Correct if needed.

NOTE: In order for system to operate correctly, all air must be bled from lines and cylinders.

STEP 5: Flow controls are installed in cover/uncover circuit of hydraulic system to control speed of arm travel. With hydraulic pump installed, there is no need to reduce or control speed with flow controls. However, flow controls can be used to reduce speed if desired. Flow controls meter flow in reverse direction, which means, when covering, flow control connected to tee is controlling speed, and when uncovering, flow control connected to flow divider/combiner is controlling speed. Adjust flow controls by turning adjustment knob. Turn clockwise to reduce speed and turn counter-clockwise to increase speed. Once speed is set as desired, lock adjustment knob in place by tightening set screw on side of knob. Flow controls should not need to be adjusted again after setting.

STEP 6: With system filled, bled and tested, make sure the fluid level in reservoir is within an inch of fill/breather hole when all cylinders are fully collapsed. Make sure breather cap is installed and any fluid spills have been cleaned up.

STEP 7: Use zip ties to clean up and organize wiring and hoses inside housing.

STEP 8: Slide front cover into place. Small holes should be at top end-larger thru holes should be at bottom end. Loosely install screws to hold cover in place until after top panel is installed. Place top panel over front cover and upper rear panel. Line up holes and loosely install screws through top panel and into front cover. Once all screws are in place, tighten down securely. Be careful not to over torque small screws and strip threads.

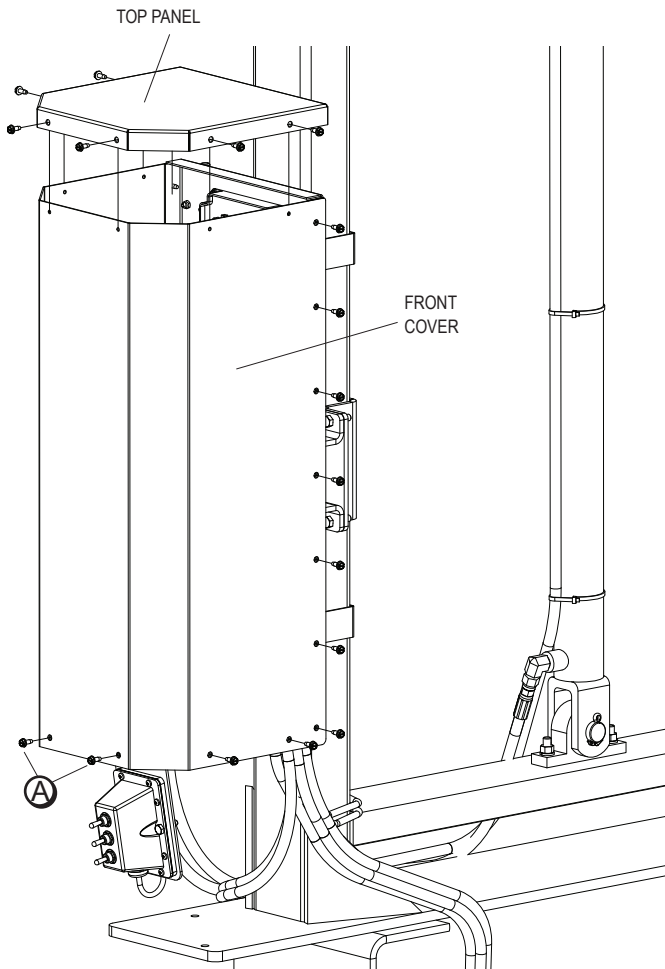

WIRELESS REMOTE & TOGGLE SWITCH OPERATION

When using wireless remote to operate SWAT® system, first press ON button on remote to turn on wireless unit. After unit is turned on by pressing ON button, buttons utilized for tarp functions will be operational. Once finished operating system, press OFF button to shut down wireless unit. If LiteAll™ work lights have been installed, turn on/off by pressing LIGHT button. Turning unit ON is not necessary for operating work lights.

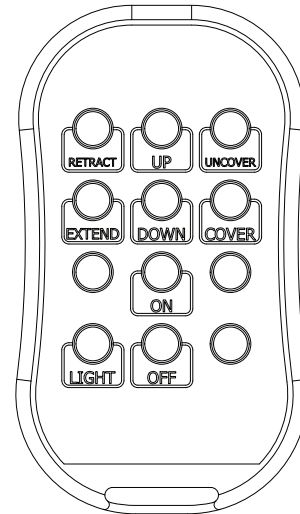

To operate system utilizing toggle switches on control box, push toggles in direction shown for each function.

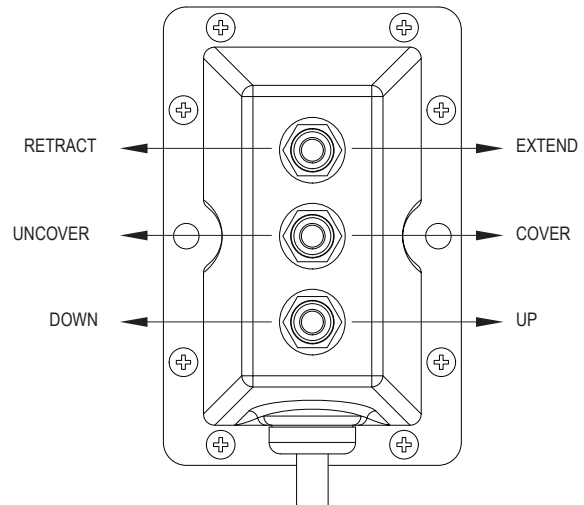

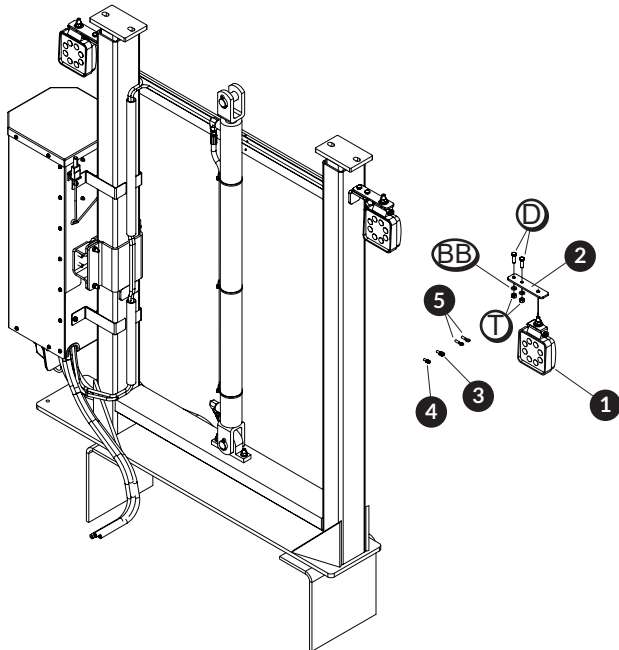

Item	Part #	Description
1.	1704719	LiteALL™ LED Worklight
2.	1809498	Light Mount Adapter Plate
3.	1705072	Quick Connect - 18 Ga. x 1/4" Male
4.	1705073	Quick Connect - 18 Ga. x 1/4" Female
5.	1705800	Ring Terminal - 18 Ga. x 5/16" Stud
D.	1704416	Hex Cap Screw - 5/16" x 1"
T.	1700411	Hex Nut - 5/16"
BB.	1700433	Lock Washer - 5/16"

STEP 1: Install light mount adapter brackets to gantry as shown using 5/16" bolts, lockwashers, and nuts.

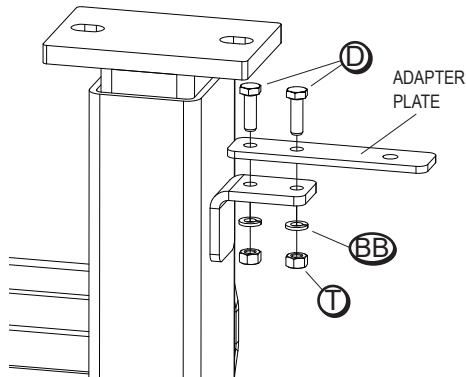

STEP 2: Remove work lights from packages and install as shown using brackets, screws, washers and nuts provided with lights.

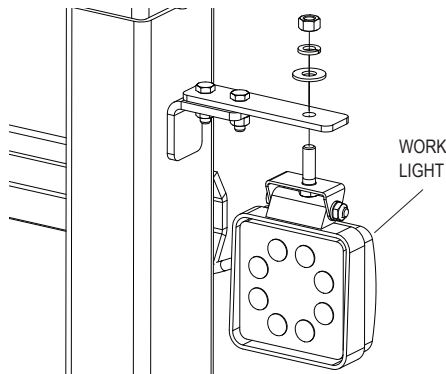

STEP 3: Route wire for lights to pump enclosure. First cut ends of wire to remove molded end plugs (not needed for this application). Route wire as shown to conduit tube and run down tube to base of gantry. Wires can then be run into pump enclosure through access hole in lower panel. Secure any loose or hanging wire with zip ties.

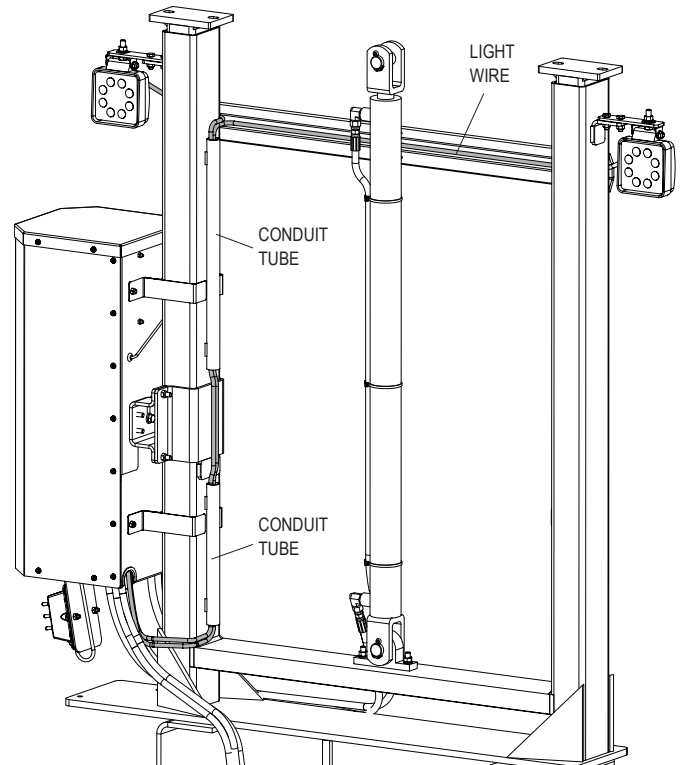

STEP 4: Make electrical connections inside pump housing. First strip 3/8" of insulation from end of loose white wire hanging from wireless module and crimp male 1/4" quick-connect terminal to wire end. Next remove outer sheathing from wire leads coming from lights to expose individual red and black wires inside.

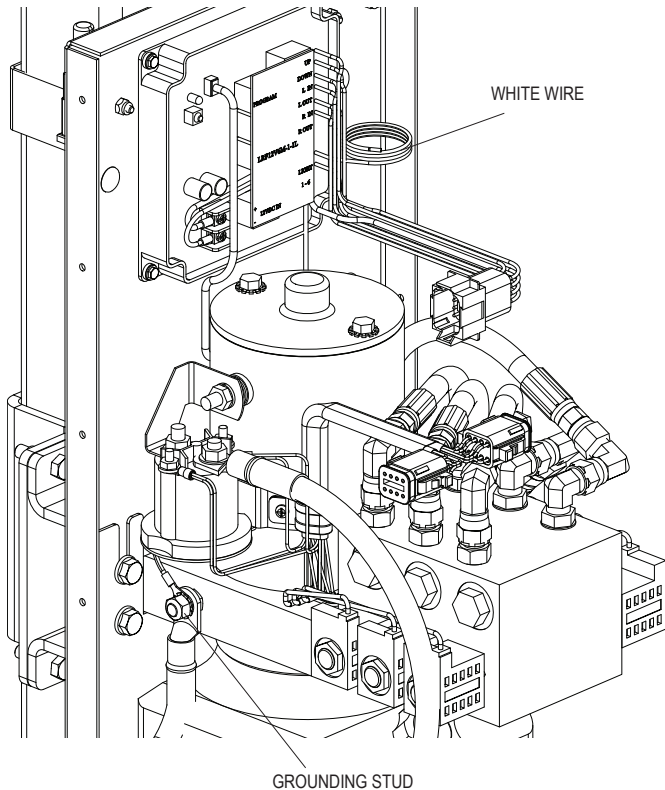

Route two red wires to white power wire. Trim off any unnecessary wire length. Strip 3/8" from end of each red wire. Twist stripped ends from red wires together, then slide female quick-connect terminal over twisted wire ends. Crimp terminal to twisted end and connect red wires to white wire with quick-connect terminals. Next route two black wires to grounding stud on side of pump. Trim off any unnecessary wire length. Strip 3/8" from end of each black wire. Twist stripped ends from black wires together, then slide a 5/16" ring terminal over twisted wire ends. Crimp terminal to twisted end and connect black wires with ring terminal to grounding stud.

REMOTE

To pair remote to control module press button directly below light on control module. Red light will turn on, press any button on remote to make connection.

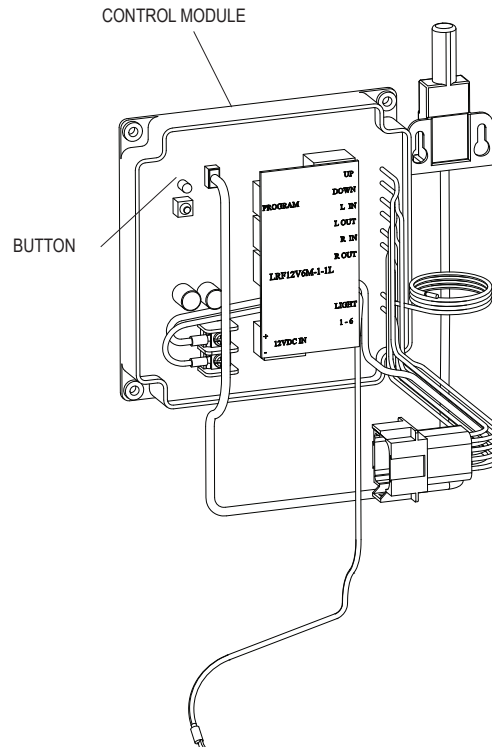



! WARNING
 ELECTROCUTION HAZARD.
 DO NOT OPERATE NEAR
 ELECTRICAL POWER LINES.
 FAILURE TO FOLLOW
 WARNINGS MAY RESULT IN
 SERIOUS INJURY OR DEATH.

DECAL P/N 1705743



! WARNING
 STAY CLEAR OF MOVING PARTS DURING
 OPERATION. FAILURE TO DO SO MAY RESULT
 IN A FALL/IMPACT CAUSING SERIOUS INJURY
 OR DEATH.

DECAL P/N 1705742

DECALS P/N 1705742 & 1705743 COME
 PREINSTALLED. ADDITIONAL DECALS
 ARE PROVIDED W/KIT IN CASE ORIGINAL
 DECALS BECOME DAMAGED.

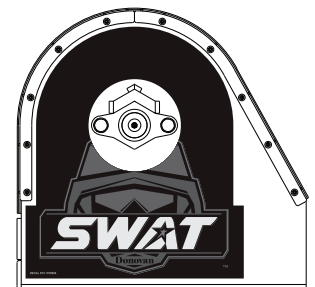

INSTALL PIVOT PLATE DECAL P/N 1705806
 ON OUTER PIVOT PLATES AS SHOWN

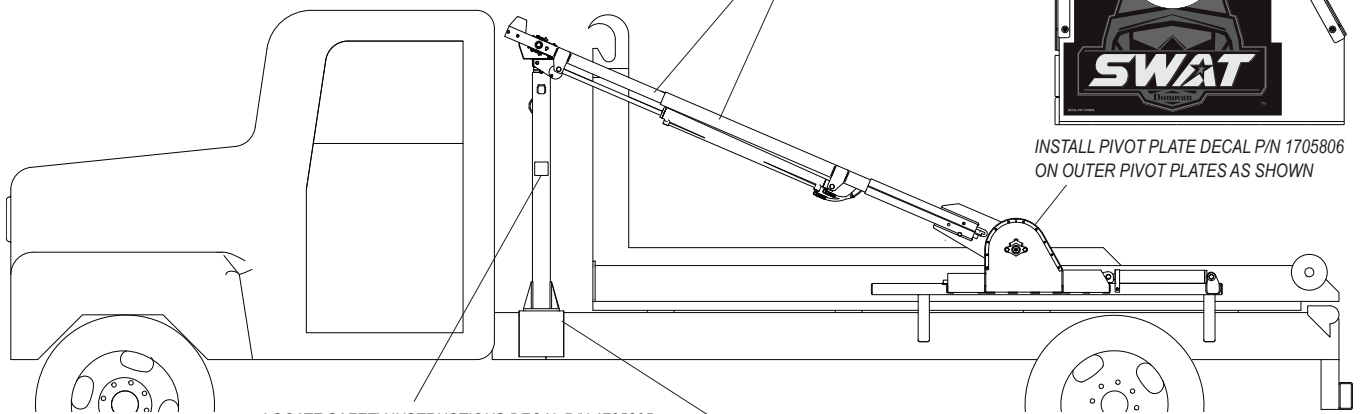

LOCATE SAFETY INSTRUCTIONS DECAL P/N 1705805
 ON LEG OF GANTRY NEAR CONTROL VALVE

PLACE CONTROL VALVE FUNCTION DECAL P/N 1705803
 NEAR CONTROL VALVE TO LABEL FUNCTIONS

SAFETY INSTRUCTIONS

1. Do not activate control lever unless moving parts are in view.
2. Before opening cover, make sure no persons or obstructions are on other side of truck out of view.
3. Keep body and clothing away from moving parts.
4. Do not raise tower or operate arms while truck is under power lines.
5. Noise level is less than 72 dBa.
6. Replace warning labels that become unreadable.
7. Always wear safety glasses during installation and repairs.

www.SHURCO.com DECAL P/N 1705805

UP DOWN	COVER UNCOVER	IN OUT
www.SHURCO.com		DECAL P/N 1705803

FINAL CHECKS & ADJUSTMENTS

- Grease arm pivot pins.
- Spray lubricant on pivot gear teeth and tube rack gear slides.
- Lubricate telescopic arm extensions.
- Spray lubricant on stud plastic pivot/swivel hose guide pivots.
- Lubricate gantry legs.
- Check all fasteners for tightness.
- Make sure welding is complete and gussets are installed where needed.
- Make sure fittings are tight and there are no leaks in hydraulic system.
- Make sure hoses are correctly fastened to stationary objects and chafe guard is installed where needed.
- Make sure telescopic arm hoses move freely with arms while arms pivot from front to rear. Hoses should be kept as short as possible to prevent them from catching on anything.
- Paint any bare metal to prevent corrosion. This includes cover control valve.

MAINTENANCE TIPS

- Check fittings and connections weekly and correct as needed.
- Grease arm pivot ins and lubricate gantry legs weekly.
- Lubricate telescopic extensions weekly.
- Spray lube pivot gears weekly.
- Readjust relief valves if needed.
- Replace/repair broken or worn parts immediately.

TIPS FOR OPERATOR

- Do not overhang roller/stabilizer far past end of container. Stabilizer bar is designed to rest on top rear of container only.
- Warning - Overshooting container and retracting arms causes arms to be unsupported, which will cause damage to arms and pivot mechanism.
- Operate engine at low RPMs only.
- Warning: Do not operate under or near overhead wires.
- Warning: Keep clear of moving parts.
- Warning: Make sure nobody is on or around container when unit is in operation.
- If arms stop moving, they have probably contacted an obstruction (this shows relief valve is working correctly). Return arms to original position and clear obstruction before reactivating system.

SYSTEM OPERATION

NOTE: Crossover relief valve is built into flow divider/combiners. Crossover relief allows cylinders to resynchronize at end of stroke or when contacting a stop, such as roll base/rest or top of container.

NOTE: In order for relief valve to function correctly and keep arms and extensions moving together: Fully extend telescoping arms, hold valve handle a few seconds, then retract, or retract all the way in, hold valve handle a few seconds and then extend out.

When covering, move arms so stabilizer bar rests on top rear of container. Hold valve handle a few seconds to resynchronize arms. When uncovering, move arms to front so roller sits in roll rest. Hold valve handle a few seconds to resynchronize arms.

Failure to follow this procedure may result in arms not moving together and possible damage to system.

TO COVER

1. Make sure no persons are on or around container or tarp unit.
2. Make sure truck is clear of overhead wires.
3. Move arms upward to clear tarp roll base/rest and cab.
4. Adjust telescopic arms in or out to clear front corner of container.
5. Raise gantry until tarp roll base/rest is even with or higher than front of container.
6. Move arms to rear to cover load, stopping about 1' away from rear of container.
7. Adjust telescopic arms so stabilizer bar aligns with top rear of container.
8. Move arms to lowest position so stabilizer bar sits on top of container.
9. Lower gantry so tarp roll base/rest is 12" to 14" below front of container.

TO UNCOVER

1. Make sure no persons are on or around container or tarp unit.
2. Make sure truck is clear of overhead wires.
3. Raise gantry until tarp roll/base rest is even with or higher than front of container.
4. Move arms to front of truck, stopping 2' to 3' from top front of container.
5. Adjust telescopic arms in or out to clear top front corner of container.
6. Lower gantry to lowest position.
7. Lower arms to about 1' to 2' from roll base/rest or cab.
8. Adjust telescopic arms in or out so roll aligns with tarp roll base/rest.
9. Lower arms to lowest position so roller sits in tarp roll base/rest.

GANTRYS & TARP ROLL BASES/RESTS

Item	Part #	Description
1.	1809152	Gantry Base Assembly
2.	1809147	Tarp Roll Base Rest Assembly
3.	1809208	Chassis Mounting Angle
4.	1202450	Cotter Pin - 3/16" x 1 1/2"
5.	1809013	Clevis Pin - 1" x 2.20"
6.	1700437	Lock Washer - 1/2"
7.	1808847	Hex Nut - 1/2"
8.	1809206	Gantry Mounting Plate
9.	1809207	Gantry Mounting Gusset
10.	1808871	Gantry Telescoping Legs
11.	1808891	Hydraulic Cylinder - 36"

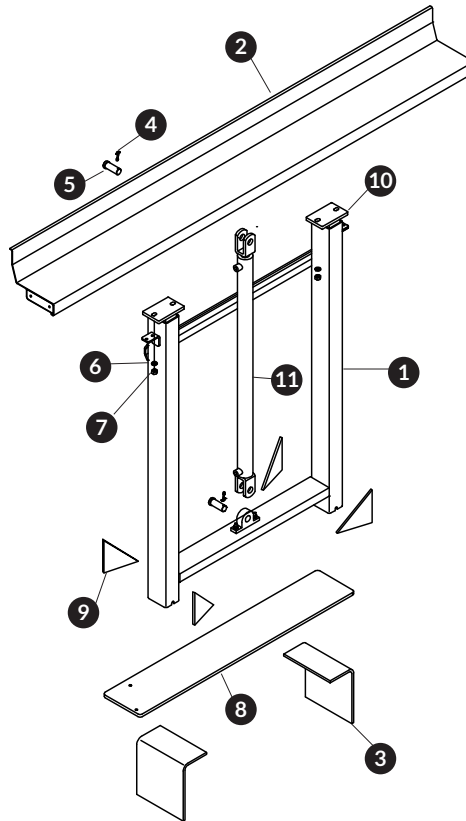

TARPS & TARP ROLLERS

Item	Part #	Description
1.	1808865	Tarp Tube
2.	1808866	Tarp Tube Bracket
3.	1809148	Tarp Tube Cap
4.	1803805	Spring-Loaded Tarp Roller
5.	1700381	Cap Screw - 1/4" x 1"
6.	1701061	Cap Screw - 3/8" x 1"
7.	1704072	Cap Screw - 7/16" x 2 1/2"
8.	1808852	Hex Nut - 7/16"
9.	1700408	Hex Nut - 1/4"
10.	1700436	Lock Washer - 1/4"
11.	1700434	Lock Washer - 3/8"
12.	1808854	Lock Washer - 7/16"
13.	1808853	Flat Washer - 7/16"

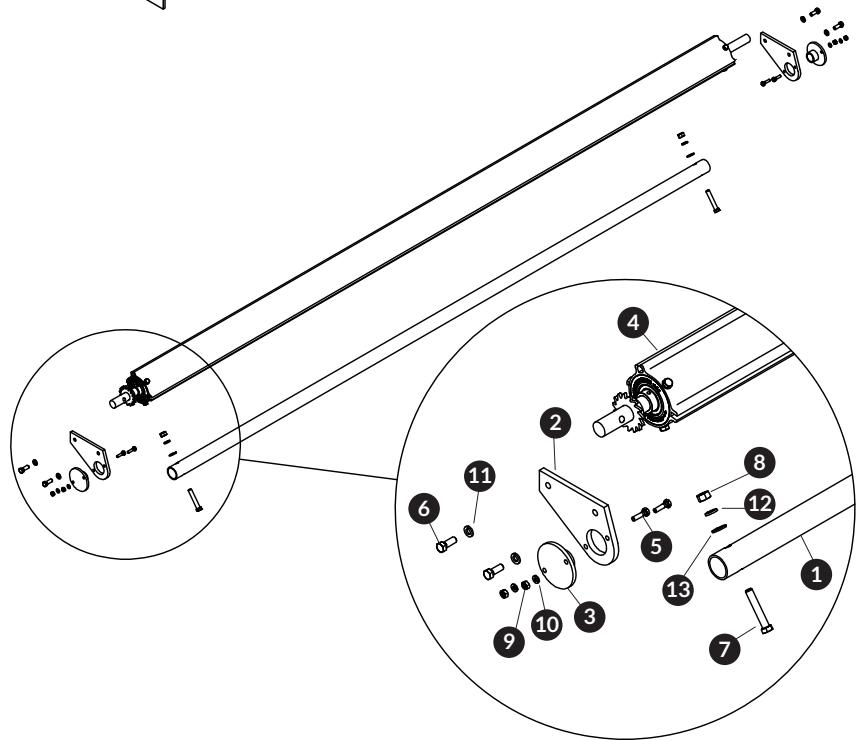

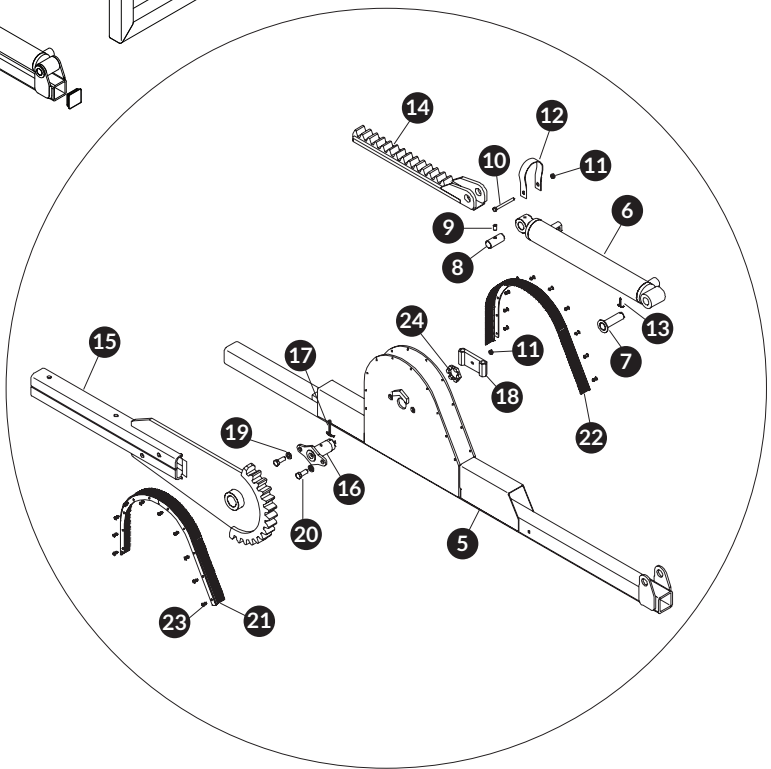
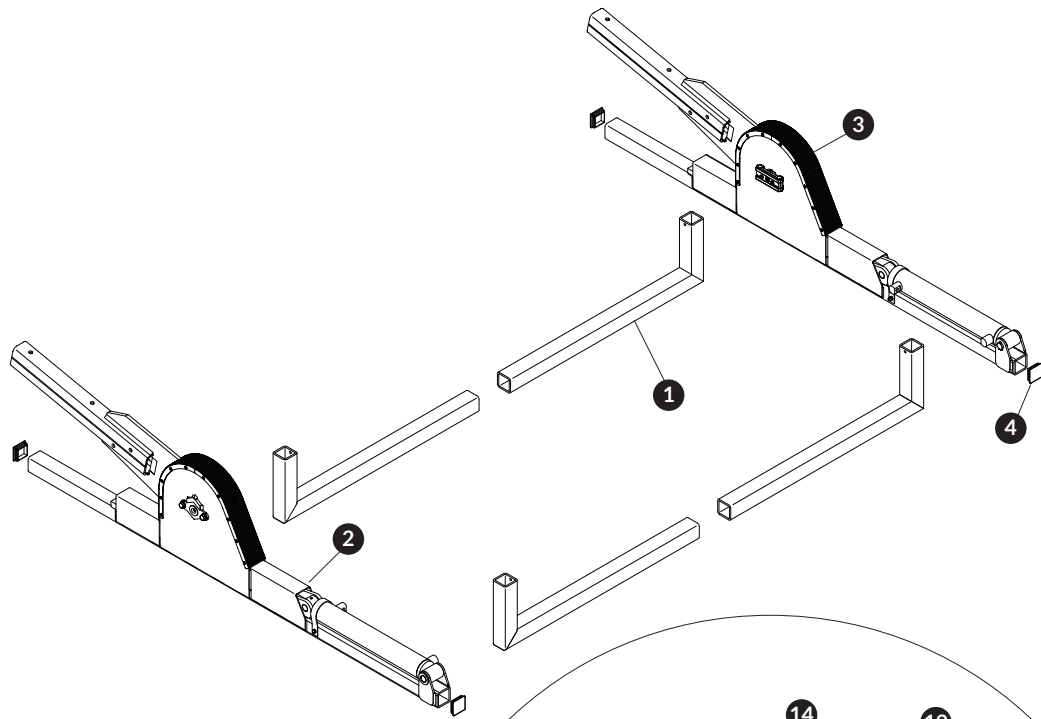

PIVOT ASSEMBLIES

Item	Part #	Description
1.	1808880	Chassis Mounting Tube
2.	1811496	Gear Pivot Assembly - Driver Side
3.	1811497	Gear Pivot Assembly - Pass. Side
4.	1808846	Square End Plug
5.	1809354	Gear Pivot Weldment - Driver Side
	1809359	Gear Pivot Weldment - Pass. Side
6.	1808890	Hydraulic Cylinder - 2 1/2" Bore
7.	1808883	Rack Cylinder Mount Pin
8.	1809014	Rack Cylinder Connecting Pin
9.	1704450	Set Screw - 3/8" x 3/4"
10.	1808863	Cap Screw - 5/16" x 3 1/4"
11.	1702492	Top Lock Nut - 5/16"
12.	1808881	Cylinder Loop Strap
13.	1808862	Rack Cylinder Connecting Pin
14.	1808886	Rack
15.	1808887	Pivot Arm
16.	1809168	Pivot Pin Assembly
17.	1808861	Cotter Pin - 3/16" x 2 1/2"
18.	1808859	Pivot Hose Guide
19.	1705793	Lock Washer - 1/2"
20.	1808939	Cap Screw - 1/2" x 1 1/4"
21.	1809366	Pivot Brush - LH
22.	1809367	Pivot Brush - RH
23.	1705741	Blind Rivet - 3/16" x 3/8"
24.	1809169	Castle Nut - 1 1/2"

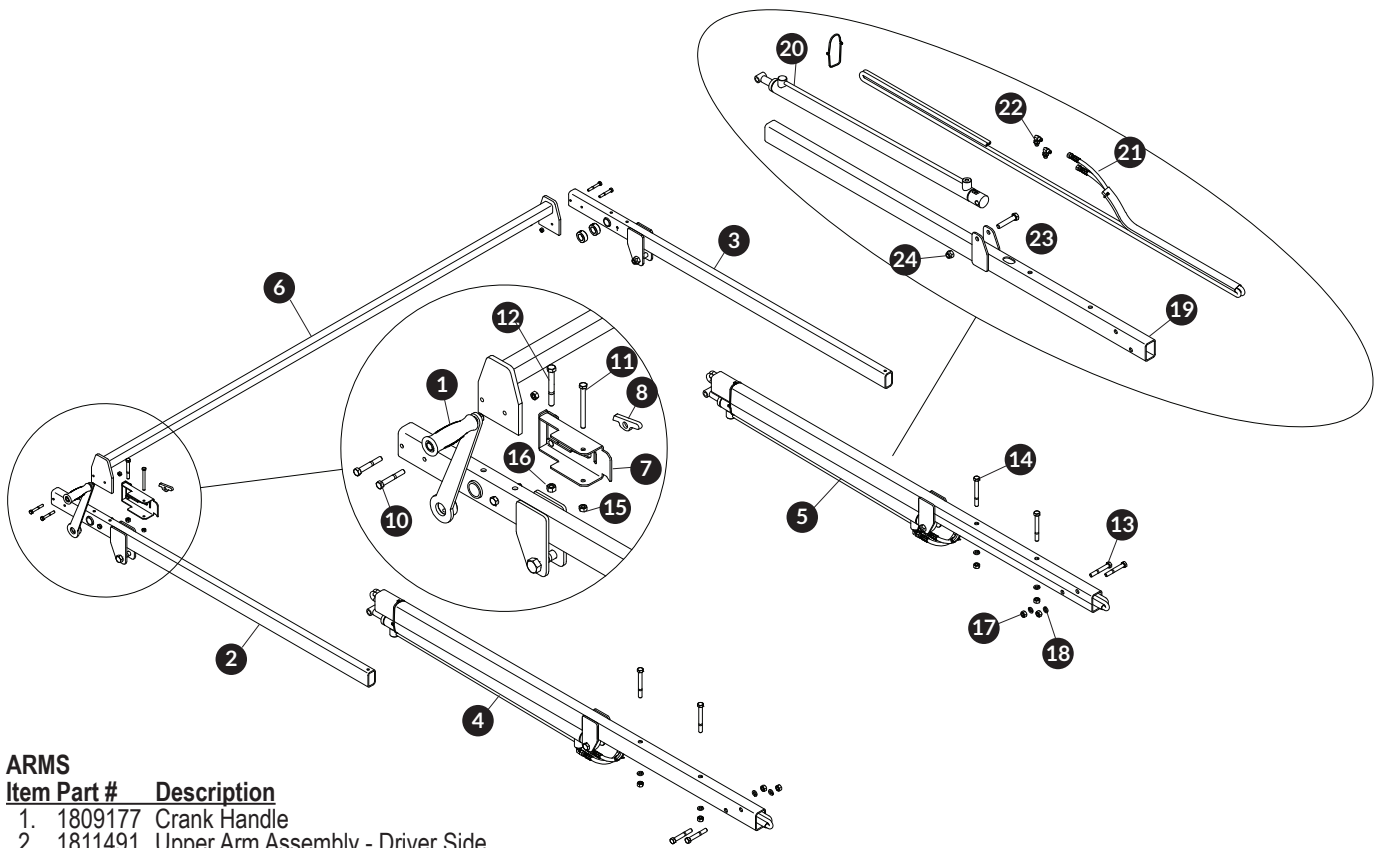
**ARMS**

Item	Part #	Description
1.	1809177	Crank Handle
2.	1811491	Upper Arm Assembly - Driver Side
3.	1811492	Upper Arm Assembly - Pass. Side
4.	1810404	Lower Arm Assembly - Driver Side
5.	1810405	Lower Arm Assembly - Pass. Side
6.	1808873	Stabilizer Bar
7.	1811487	Ratchet Guard Assembly
8.	1809209	Ratchet Pawl
9.	1808855	Locking Collar - 1" ID
10.	1808850	Cap Screw - 5/16" x 2 1/4"
11.	1201022	Cap Screw - 5/16" x 3 1/2"
12.	1700371	Cap Screw - 3/8" x 3"
13.	1808848	Cap Screw - 1/2" x 3 1/2"
14.	1808849	Cap Screw - 1/2" x 4 1/2"
15.	1702492	Top Lock Nut - 5/16"
16.	1702668	Top Lock Nut - 3/8"
17.	1808847	Hex Nut - 1/2"
18.	1700437	Lock Washer - 1/2"
19.	1810403	Lower Arm Weldment
20.	1808892	Hydraulic Cylinder
21.	1808935	Hydraulic Hose - 1/4" x 16'
22.	1705725	Hydraulic Fitting - #6 JICM x #6 ORBM - EL 90
23.	1808856	Cap Screw - 5/8" x 3 1/4"
24.	1808843	Top Lock Nut - 5/8"

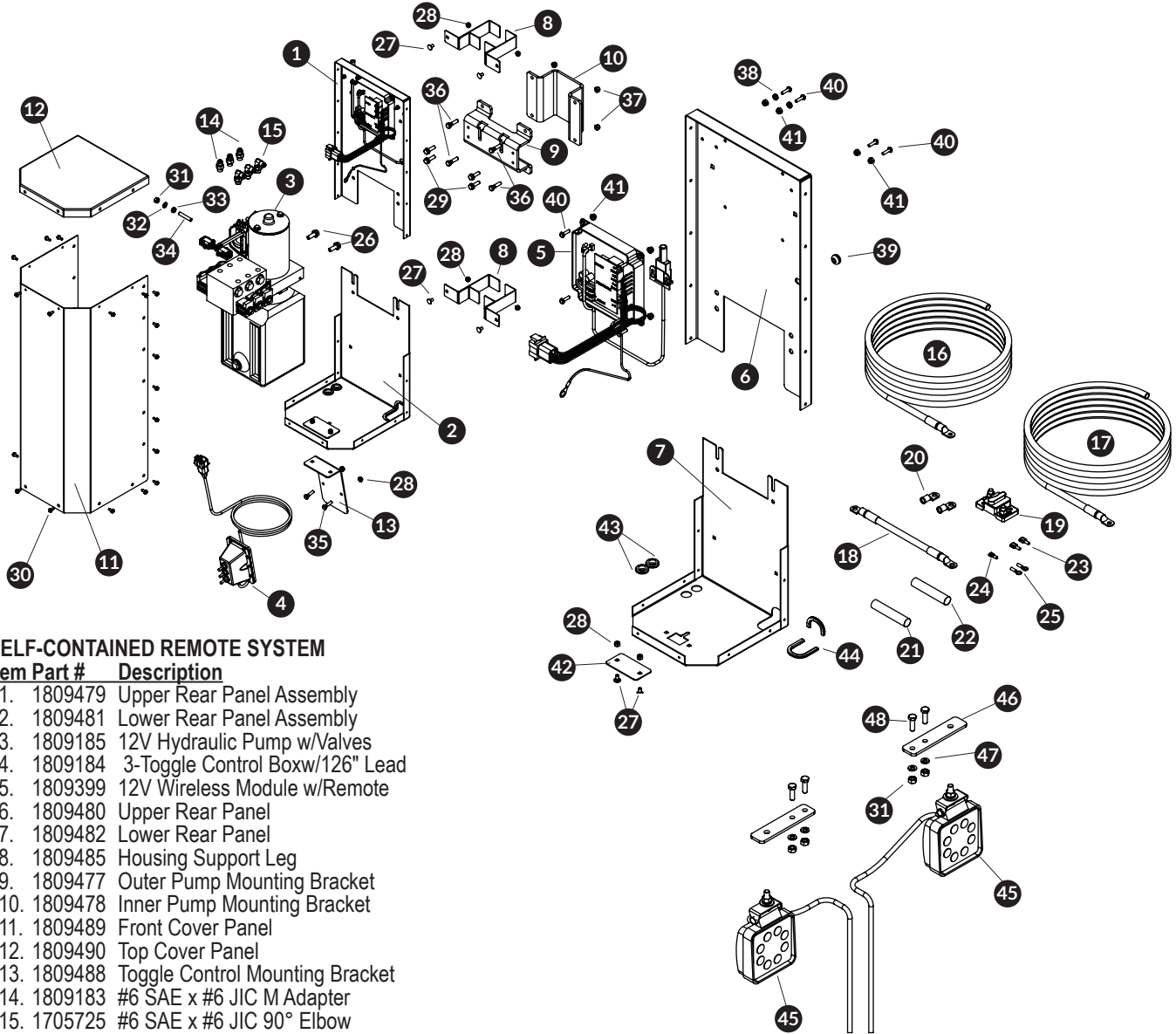

SELF-CONTAINED REMOTE SYSTEM

Item	Part #	Description
1.	1809479	Upper Rear Panel Assembly
2.	1809481	Lower Rear Panel Assembly
3.	1809185	12V Hydraulic Pump w/Valves
4.	1809184	3-Toggle Control Boxw/126" Lead
5.	1809399	12V Wireless Module w/Remote
6.	1809480	Upper Rear Panel
7.	1809482	Lower Rear Panel
8.	1809485	Housing Support Leg
9.	1809477	Outer Pump Mounting Bracket
10.	1809478	Inner Pump Mounting Bracket
11.	1809489	Front Cover Panel
12.	1809490	Top Cover Panel
13.	1809488	Toggle Control Mounting Bracket
14.	1809183	#6 SAE x #6 JIC M Adapter
15.	1705725	#6 SAE x #6 JIC 90° Elbow
16.	1809494	1/0 Cable x 17' Red
17.	1809495	1/0 Cable x 17' Black
18.	1809496	Breaker Lead Wire
19.	1809466	Circuit Breaker - 225A Manual Reset
20.	1809460	Cable Eyelet - 1/0 AWG x 3/8" Stud
21.	1809464	Heat Shrink - 3/4" ID - Red
22.	1809465	Heat Shrink - 3/4" ID - Black
23.	1705072	Quick Connect - 18 Ga. x 1/4" Male
24.	1705073	Quick Connect - 18 Ga. x 1/4" Female
25.	1705800	Ring Terminal - 18 Ga. x 5/16" Stud
26.	1809468	Hex Flange Cap Screw - 3/8" x 1"
27.	1704906	Carriage Bolt - 1/4" X 1/2"
28.	1701543	Nylock Nut - 1/4"
29.	1809469	Hex Flange Cap Screw - 5/16" x 1"
30.	1809472	Self-Tapping Screw - #10 x 1/2"
31.	1700411	Hex Nut - 5/16"
32.	1704912	Lock Washer - 5/16"
33.	1809471	Jam Nut - 5/16"
34.	1809470	Stud - 5/16" x 1-3/4"
35.	1700381	Cap Screw - 1/4" x 1"
36.	1701208	Cap Screw - 5/16" x 1-1/4"

SELF-CONTAINED REMOTE SYSTEM

Item	Part #	Description
37.	1700419	Nylock Nut - 5/16"
38.	1704869	Hex Nut - #8-32
39.	1809474	Rubber Grommet - 3/16" ID x 11/32" OD
40.	1809475	Hex Flange Screw - #8-32 x 5/8"
41.	1809476	Nylock Nut - #8-32
42.	1809483	Cover Plate
43.	1809473	Rubber Grommet - 5/8" ID x 7/8" OD
44.	1809484	Rubber Edge Trim

LITEALL™ COMPONENTS

Item	Part #	Description
	1809500	SWAT™ Self-Combined LiteALL™ Kit
45.	1704719	Work Light
46.	1809498	LiteALL™ Mounting Plate
47.	1700433	Lock Washer - 5/16"
48.	1704416	Cap Screw - 5/16" x 1"

3353 GRAN PARK WAY • STUART, FL 34997
PHONE: 1-800-327-8287 • FAX: 1-772-287-0431
www.DONOVAN-TARPS.com
