

**STEP 1:** Determine location and drill 2" hole through trailer skin.

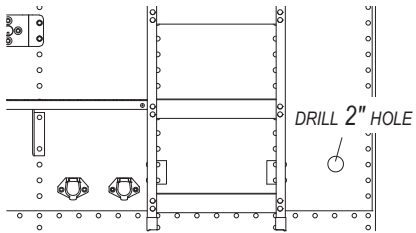

**NOTE:** In order to clear travel area of front arm, locate Shur-Co® wireless receiver as low as possible on front of trailer.

**STEP 2:** Align hole in wireless receiver over 2" hole in trailer as shown below. Using holes in flanges on receiver base as guide, mark and drill four 5/16" holes as shown.

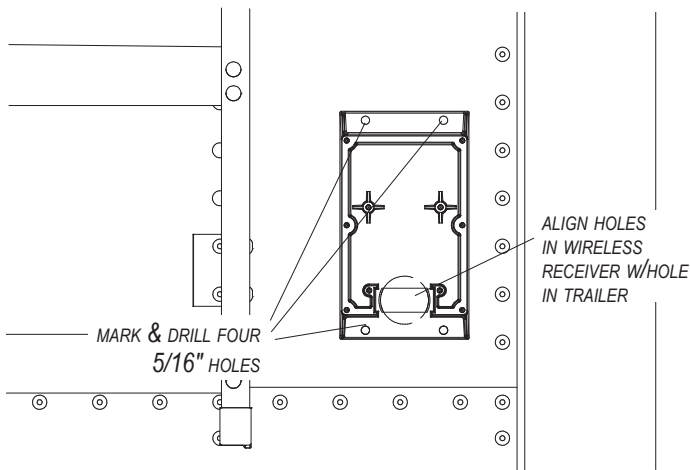

**STEP 3:** Align holes on wireless receiver with holes on trailer. Fasten receiver to trailer with 5/16" x 7/8" cap screws, lock washers and nylon lock nuts. Adhere warning decal P/N 1705546 above receiver in location shown.

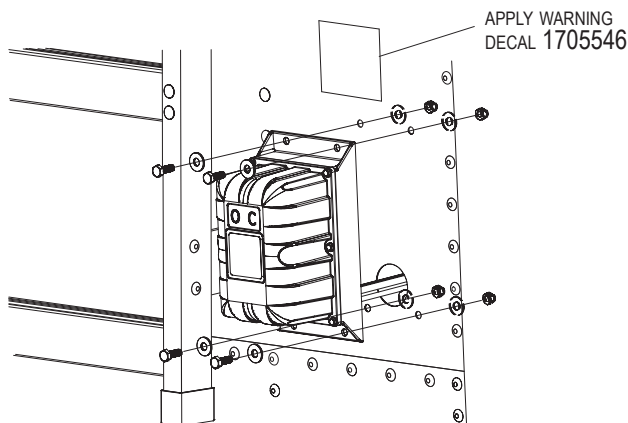

**WIRING SCHEMATIC**

**STEP 1:** Connect SMARTwire™ from wireless receiver to SMARTwire™ from electric motor. Connect SMARTwire™ plug from wireless receiver to SMARTwire™ from dual-conductor socket. Secure connections with lock pins. If you have a ShurLink™ system, connect encoder wire from receiver to encoder wire from motor. Secure wires to trailer with cable clips and screws. If needed, use cable ties.

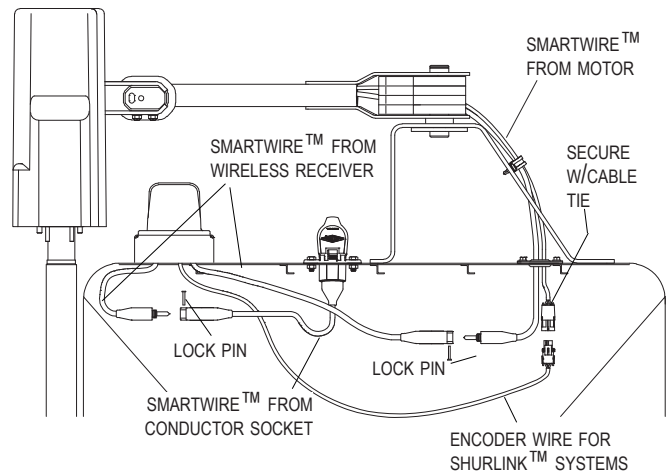

**NOTE:** Coat each connection with dielectric grease (P/N 1704378) to prevent corrosion.

**CAUTION**

Check all hardware for complete assembly before operating. Inspect system at this time and adjust as required.

**STEP 2:** Check motor direction by pressing either button. If button is released and operation continues, system is in *Express Mode*. To stop operation, press button again. If switch is running system backwards, program remote to wireless receiver and rewire as directed in troubleshooting guide in remote instructions.

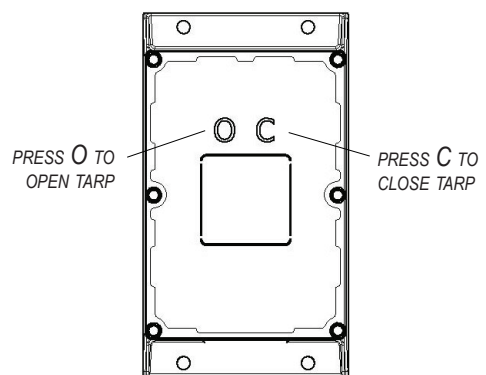

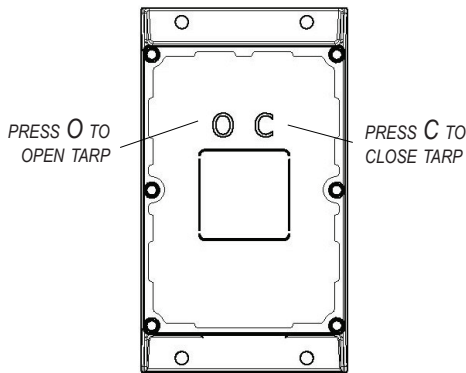

**NOTE:** 4500 Series HD trailer-mounted control boxes now operate in **EXPRESS MODE**, for both ShurLink™ remote systems. Pressing the O or C button on the control box initiates an express open or close operation. After that, pressing either button on the box will stop tarp operation. If neither button is pressed, operation will automatically stop at end of travel. Both EZR™ and PRO remotes are shipped with tarp channel set to **EXPRESS MODE**, and can be configured as desired.

**NOTE:** Tarp systems will operate in **EXPRESS MODE** when using buttons on trailer-mounted control box, if encoder wires are connected. When in **MANUAL MODE**, press and hold buttons (operation will stop if button is released). See remote instruction manual for detailed instructions on remote operation.

**NOTE:** Tarp systems will operate in **EXPRESS MODE** when commanded to operate from buttons on trailer-mounted control box. Closing remote lid or pressing select button will not stop system in this case. Pressing OPEN or CLOSE button on remote (if on system channel) will stop system if in range.

**! WARNING**

**DO NOT OPERATE MOTORIZED SYSTEMS WHILE INDIVIDUALS ARE ON OR OCCUPYING BOX/TRAILER/HOPPER.**

Decal P/N 1705546

**! NOTICE**

THIS TARP SYSTEM OPERATES IN EXPRESS MODE. UPON PRESSING THE **O**PEN/**C**LOSE BUTTON THE TARP SYSTEM WILL CONTINUE TO TRAVEL TO THE END STOPS. TO STOP THE MOTOR, PRESS EITHER BUTTON. READ OWNERS MANUAL BEFORE OPERATING. CONTACT SHUR-CO® FOR ALL TARP SYSTEM QUESTIONS AT 1-866-748-7435.

**! NOTICE**

Decal shown above must be placed above wireless receiver on front of box.

**! WARNING**

Do not stand or climb on flex arm. Standing or climbing on flex arm could result in fall/impact causing serious injury or death.

**! WARNING**

Stay clear of the roll tarp and arm(s) sweep area, from front-to-back, during operation. Failure to do so may result in a fall/impact causing serious injury or death. For repair/service of equipment, reference manual for proper safety precautions before proceeding.

Decal P/N 1705523

**! WARNING**

Stay clear of the roll tarp and arm(s) sweep area from front-to-back, during operation. Failure to do so may result in a fall/impact causing serious injury or death. For repair/service of equipment, reference manual for proper safety precautions before proceeding.

**SHUR-CO® 4500HD**

1-800-474-8756 • www.SHURCO.COM

**NO STEP**

