



# SHUR-LOK®

## FOR TENDERS/SPREADERS



A004FL-0620

### FEATURES AND BENEFITS



- Waterproof Protection
- Powder-Coated Easy-Off Tarp
- Stops w/ Stainless Bodies
- Stainless Bows/Brackets
- Stainless End Caps
- Stretch Cord Return
- Standard Crank Arm
- 18-Oz. Vinyl Tarp

Whatever you're hauling, from seed to blended fertilizer to micronutrients, it's critical that contents stay dry. Shur-Lok® is water resistant, durable and easy to open and close. Stainless steel and powder-coated components provide lasting corrosion resistance.

Stainless steel and powder-coated parts come standard, to protect against the corrosion inherent in hauling caustic substances like fertilizer. Stainless bows and brackets, end caps, ridge straps and crank retainers offer improved performance, longer life and a sharper appearance. Even our standard-issue easy-off tarp stops feature a stainless steel stop body, plus powder coating for lasting durability.



800.474.8756

WWW.SHURCO.COM

# SHUR-LOK® BOX DETAILS For Farm Bodies, Fertilizer Tenders and Spreaders

CORRECT PHYSICAL MEASUREMENTS ARE ESSENTIAL FOR PROPER TARP FIT. PROVIDE ALL REQUESTED INFORMATION OR YOUR ORDER MAY BE DELAYED. **DO NOT USE** UNIVERSAL BOX SIZES. **ALWAYS** USE ACTUAL MEASUREMENTS.

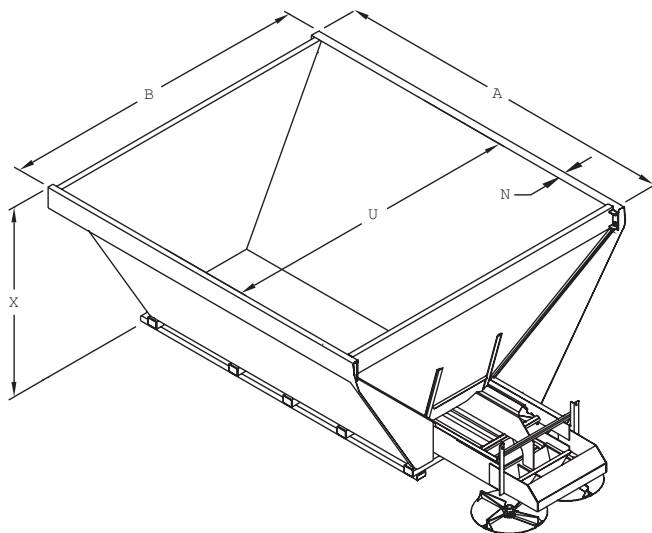
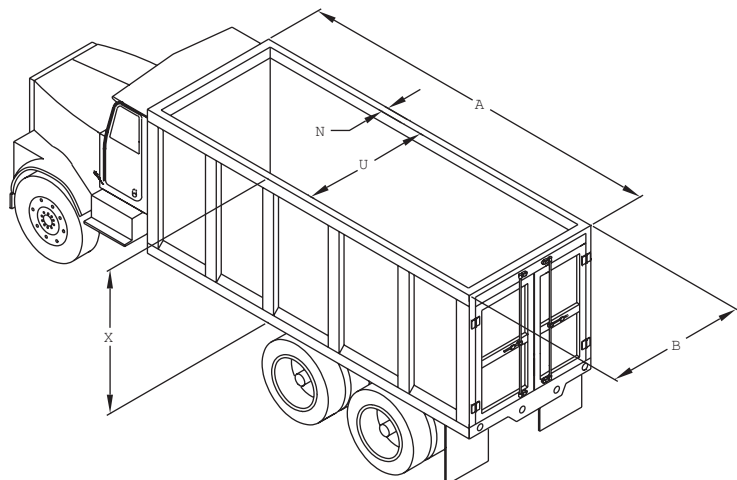
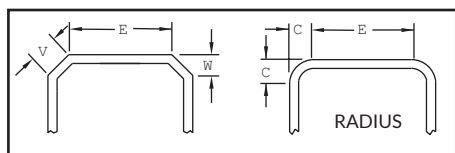

FIGURE 1



## CONTACT INFORMATION

G02BD-0512

NAME \_\_\_\_\_  
 ADDRESS \_\_\_\_\_  
 EMAIL \_\_\_\_\_  
 CITY \_\_\_\_\_ STATE \_\_\_\_\_ ZIP \_\_\_\_\_  
 PHONE \_\_\_\_\_ FAX \_\_\_\_\_  
 BOX/TRAILER MAKE \_\_\_\_\_  
 MODEL \_\_\_\_\_ YEAR \_\_\_\_\_

## BOX DIMENSIONS

A \_\_\_\_\_ UPPER BOX LENGTH  
 B \_\_\_\_\_ UPPER BOX WIDTH  
 Front \_\_\_\_\_ Center \_\_\_\_\_ Rear \_\_\_\_\_  
 N \_\_\_\_\_ TOP RAIL WIDTH  
 U \_\_\_\_\_ INSIDE BOX WIDTH  
 X \_\_\_\_\_ OUTSIDE BOX HEIGHT FROM GROUND

CORNER CONFIGURATION *See Figure 1*

SQUARE  DIAGONAL  RADIUS

C \_\_\_\_\_ OUTSIDE CORNER RADIUS *For all radius fronts*  
 E \_\_\_\_\_ FLAT ACROSS FRONT  
 V \_\_\_\_\_ FLAT ACROSS DIAGONAL  
 W \_\_\_\_\_ DIAGONAL DEPTH

### IF SPREADER:

GRANULAR BIN:  INSIDE BOX  OUTSIDE BOX  
 SPREADER STYLE:  SELF-PROPELLED  AIR SYSTEM  
 SPINNER  PULL-TYPE SPINNER

### IF TENDER:

MOUNTING STYLE:  TRUCK  TENDER  
 SPREADER STYLE:  REAR  SIDE-FOLD REAR  
 REAR OVER BOX

### TARP WEIGHT\*

18 OZ.  22 OZ.

\*Tarps for spreaders ONLY available in 18-oz. fabric weight.

TARP COLOR(S) \_\_\_\_\_